

# G

## GIUNTO ELASTICO ELASTIC COUPLING ELASTISCHER KUPPLUNG



### Giunto elastico G

#### Riduttori a ingranaggi e a vite senza fine

##### Serie riduttori:

- RD a ingranaggi
- RS a vite senza fine
- RT a vite senza fine

##### Flange motore:

- IEC72/DIN42948: B5/B14
- NEMA: C / TC



### Elastic coupling G

#### Helical and worm speed reducers

##### Speed reducer series:

- RD helical
- RS worm
- RT worm

##### Motor flanges:

- IEC72/DIN42948: B5/B14
- NEMA: C / TC



### elastische Kupplung G

#### Stirnrad- u. Schnecke- getriebe

##### Getriebe Baureihe:

- RD Stirnrad
- RS Schnecke
- RT Schnecke

##### Motorflansche:

- IEC72/DIN42948: B5/B14
- NEMA: C / TC

# VARVEL - G

GIUNTO ELASTICO  
ELASTIC COUPLING  
ELASTISCHEKUPPLUNG

## • Semigiunto riduttore

- Integrale in acciaio
- Supporto con due cuscinetti
- Dimensioni entrata invariate

## • Anello elastico

- Corona dentata in Poliuretano TPU
- Denti collegati esternamente
- Durezza 98 Shore A (rosso)
- Temperatura -30 / +100 °C

## • Semigiunto motore

- Alluminio pressofuso
- Bilanciatura dinamica
- Calettamento con morsetto
- Fori IEC e Nema

## • Vantaggi

- Un solo riduttore per rapporto
- Maggiore flessibilità
- Rotazione stock aumentata
- Eliminazione ossidazione per sfregamento (tribocorrosione)
- Gioco zero nel collegamento
- Disallineamento angolare 1° max.
- Rigidità torsionale
- Smorzamento vibrazioni

## • Reducer half-coupling

- Steel built-in
- Two-bearing arrangement
- Unchanged input dimensions

## • Spider

- TPU polyurethane-cast elastic element
- External tooth connection
- 98 Shore A (red) hardness
- Temperature -30 / +100 °C

## • Motor half-coupling

- Aluminium pressure die cast
- Dynamic balancing
- Clamp fit
- IEC and Nema bores

## • Advantages

- One gearbox only for each ratio
- Greater flexibility
- Increased stock rotation
- Fretting corrosion elimination
- Coupling zero backlash
- Angular misalignment 1deg. max.
- Torsional rigidity
- Vibration damping

## • Getriebekupplungshälfte

- integrierte Stahl
- Zwei-Lager-Anordnung
- unveränderte eingang Abmessungen

## • Kupplungsscheibe

- elastisches Element aus TPU Polyurethan
- äußerliche Zahnverbindung
- 98 Shore A (rot) Härte
- Temperatur -30 / +100 °C

## • Motorkupplungshälfte

- Aluminium Druckguss
- Dynamische Auswuchtung
- Klemm Verbindung
- IEC u. Nema Bohrungen

## • Vorzüge

- nur eine Getriebekomponente je Übersetzung
- gesteigerte Flexibilität
- höher Lagerumschlag
- Vermeidung von Passungsrost
- spielfrei Verbindung
- Winkelausgleich bis 1°
- Verdrehsteifigkeit
- Dämpfung von Schwingungen

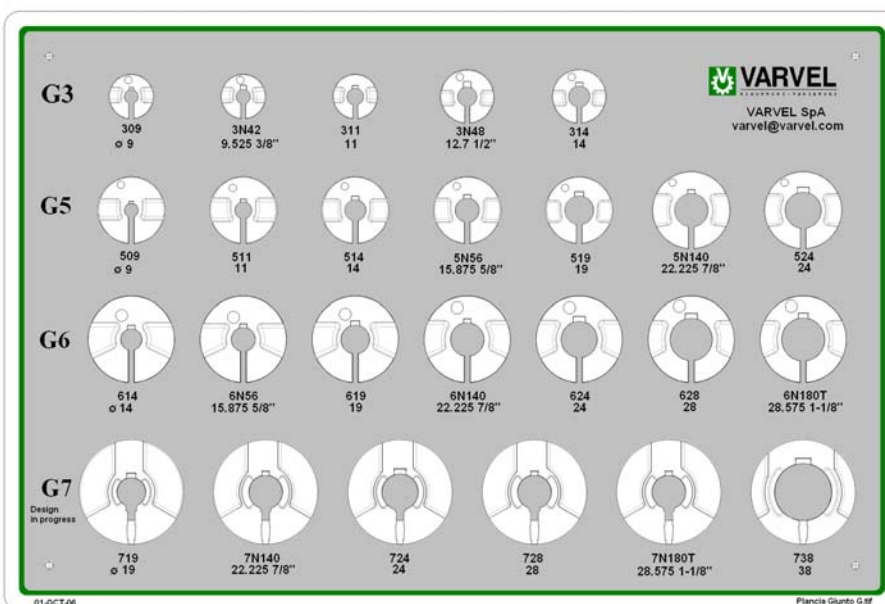

# VARVEL - G

GIUNTO ELASTICO  
ELASTIC COUPLING  
ELASTISCHEKUPPLUNG

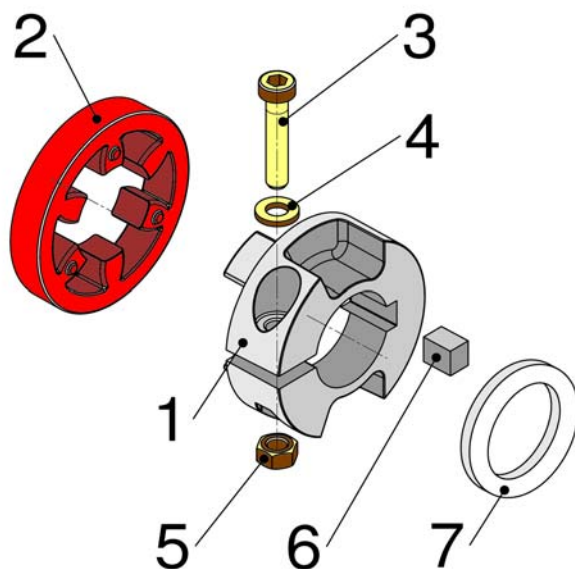

Tipo Giunto Coupling Type Kupplungstyp	Foro Bore Bohrung [mm]	Coppia di serraggio vite (3) Screw locking torque (3) Schraubenklemmen- drehmoment (3) [Nm]	Coppia trasmissibile [Nm] Transmissible torque [Nm] übertragbar Drehmoment [Nm]	
			con chiavetta (6) with key (6) mit Keil (6)	senza chiavetta (6) without key (6) ohne Keil (6)
G3	9	4.5 ÷ 6	14	8 ÷ 10
	11	4.5 ÷ 6	15	8 ÷ 10
	14	8.9 ÷ 10	30	20 ÷ 25
G5	9	8.9 ÷ 10	14	8 ÷ 10
	11	8.9 ÷ 10	15	8 ÷ 10
	14	8.9 ÷ 10	30	12 ÷ 17
	19	8.9 ÷ 10	40	20 ÷ 25
	24	8.9 ÷ 10	70	30 ÷ 40
G6	14	15.3 ÷ 18	60	30 ÷ 40
	19	15.3 ÷ 18	90	50 ÷ 65
	24	15.3 ÷ 18	130	85 ÷ 100
	28	15.3 ÷ 18	180	100 ÷ 120