

ULTRASONIC FLOWMETER

MODEL LF810

INSTRUCTION MANUAL

TOSHIBA INTERNATIONAL CORPORATION**NOTES**

Before using the equipment, please read this manual carefully and understand the contents, and then use the equipment as recommended.

- **NEVER** attempt to operate the equipment in any way that deviates from that described in this instruction manual.
 - After reading this manual, store it with care in a place where it can be referred to whenever needed.
 - Please be sure that this manual is delivered to the personnel who will use this product.
-

Write down the address and phone number of the distributor from which you purchased this product, the product code, SER.NO. Etc.

Distributor	Address _____
	Name _____
	Phone number () —
Product code	<u>LF</u> _____
SER.NO	_____











Safety Precautions

The following safety precautions contain important information pertaining to the safe use of the Ultrasonic Flowmeter. Read this text carefully and make sure to fully understand its contents before installing and operating this equipment. Follow the directions given herein at all times when the unit is operational. Toshiba International Corporation is not at all liable for any injury and/or a damage resulting from misuse of this equipment by the user that is contrary to these cautionary notes.

For quick reference, store this manual in a designated location with easy access (preferably near the equipment).

The following safety symbols in this manual and on the equipment are used to ensure the equipment is used safely and to protect operators and property from possible hazards or damage. Read the explanations below carefully and familiarize yourself with the symbols before operating this equipment.

Safety symbols

 DANGER	Indicates that incorrect usage can result directly in death or serious injury to the operator.
 WARNING	Indicates that incorrect usage may result in loss of life or serious injury to the operator.
 CAUTION	Indicates that incorrect usage may result in injury to the operator or damage to the equipment.
 NOTE	Indicates referring to information for usage of the function or features. (Put on the equipment)
	Indicates attention to information for usage of the function or features.
	Indicates Protective conductor terminal
	Indicates Earth terminal (Functional earth terminal)
	Indicates nearby power supply voltage line.
	Indicates Alternating current, "AC".
	Indicates Direct current, "DC".

Part Identification:

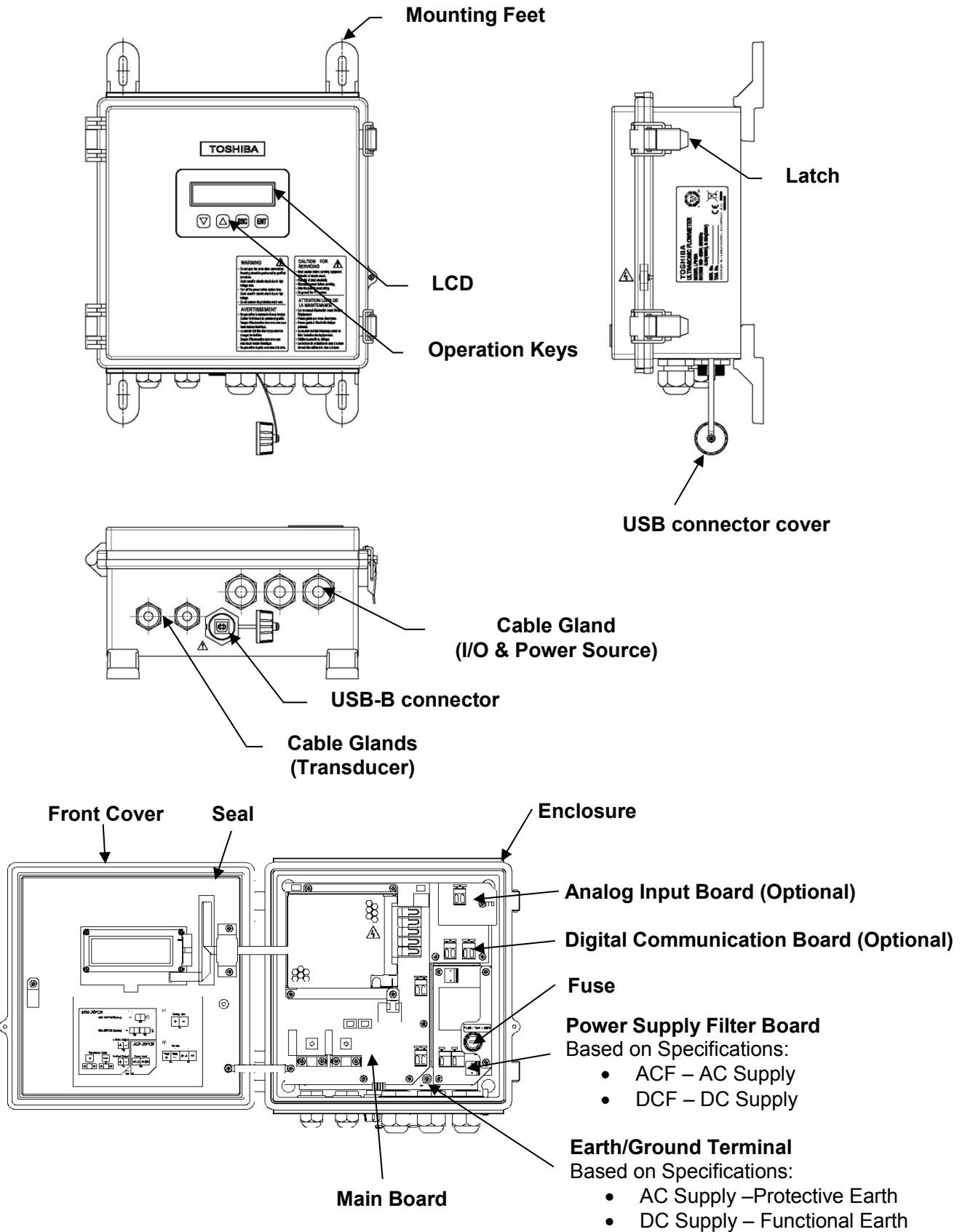

Labels and attached place

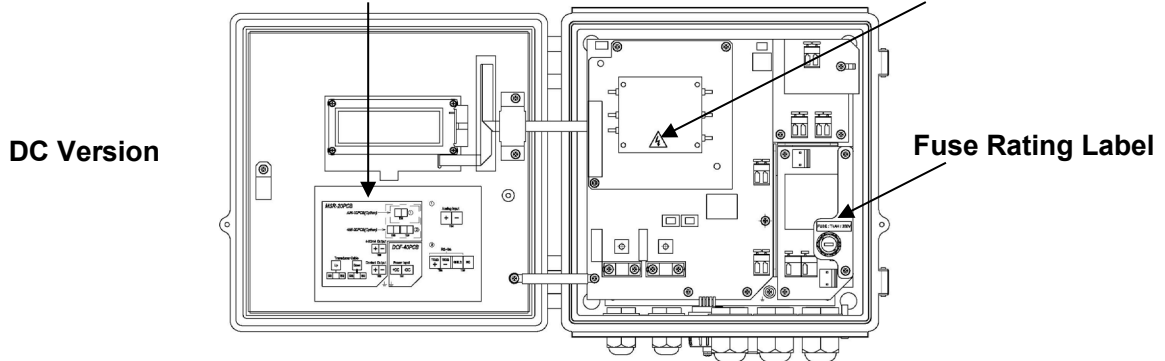
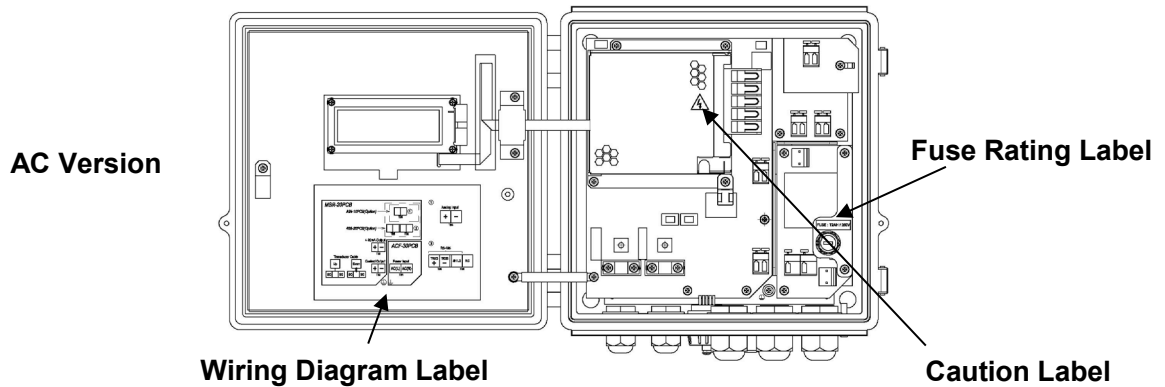
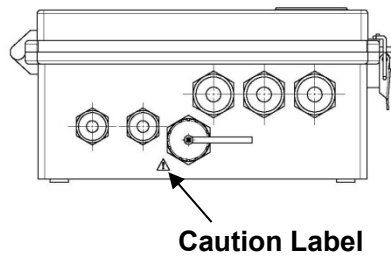
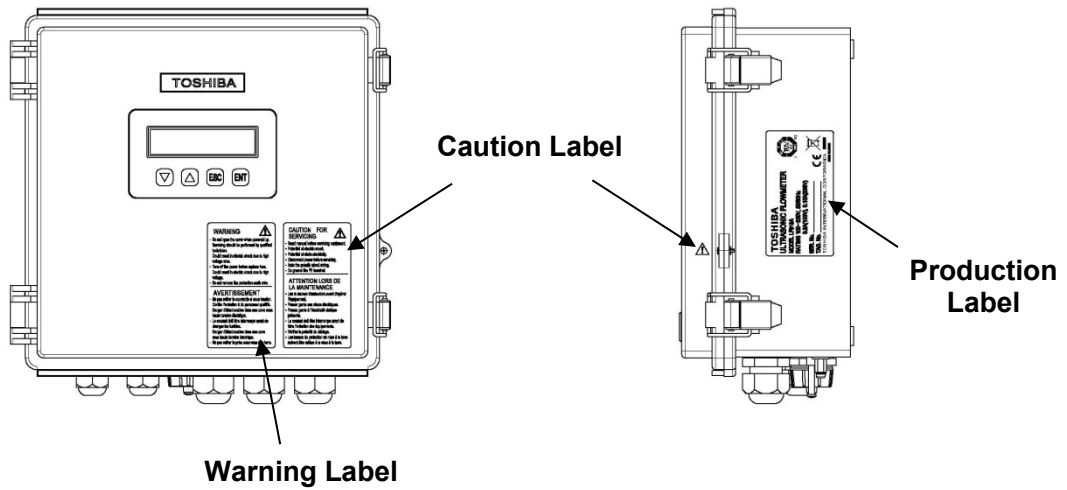

Labels attached to the equipment are as follows.

[Warning Label]

- Indicates that incorrect usage may result in death or serious injury to the operator.

[Caution Label]

- Indicates that incorrect usage may result in loss of life or serious injury to the operator.

WARNING 

- Do not open the cover when powered up. Servicing should be performed by qualified technician. Could result in electric shock due to high voltage area.
- Turn off the power before replace fuse. Could result in electric shock due to high voltage.
- Do not remove the protection earth wire.

AVERTISSEMENT

- Ne pas retirer le couvercle si sous tension. Confier l'entretien à du personnel qualifié. Danger d'électrocution dans une zone sous haute tension électrique.
- Le courant doit être interrompu avant de changer les fusibles. Danger d'électrocution dans une zone sous haute tension électrique.
- Ne pas retirer la prise avec mise à la terre.

CAUTION FOR SERVICING 

- Read manual before servicing equipment.
- Potential of electric shock.
- Potential of static electricity.
- Disconnect power before servicing.
- Note the polarity about wiring.
- Do ground the PE terminal.

ATTENTION LORS DE LA MAINTENANCE



- Lire le manuel d'instruction avant d'opérer l'équipement.
- Prenez garde aux chocs électriques.
- Prenez garde à l'électricité statique présente.
- Le courant doit être interrompu avant de faire l'entretien des équipements.
- Vérifier la polarité du câblage.
- Les bornes de protection de mise à la terre doivent être reliées à la mise à la terre.



[Production Label]



[AC Power Supply]

TOSHIBA
ULTRASONIC FLOWMETER
 MODEL LF810A
 RATING 100—230V, 50/60Hz
 0.2A(100V), 0.15A(230V)
 SER. No. _____
 TAG. No. _____
TOSHIBA INTERNATIONAL CORPORATION
 MADE IN JAPAN

[DC Power Supply (Optional)]

TOSHIBA
ULTRASONIC FLOWMETER
 MODEL LF810D
 RATING 24V \pm 20 %
 0.42A
 SER. No. _____
 TAG. No. _____
TOSHIBA INTERNATIONAL CORPORATION
 MADE IN JAPAN

[Rating Label]

Fuse Rating

[AC Power Supply]

FUSE : T4AH / 250V

[DC Power Supply]

FUSE : T4AH / 250V

Earth

[Protective Earth]



[Functional Earth]



[Wiring Diagram for AC Power Supply]

[Wiring diagram for DC Power Supply]

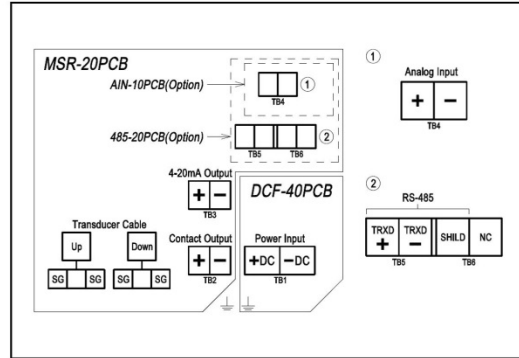
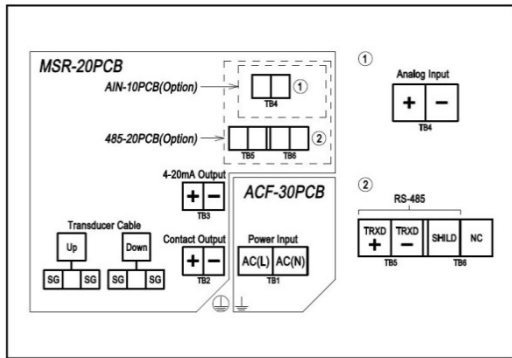

Usage Precautions

This instrument is used to measure flow quantities by means of ultrasound. For safe usage and optimum performance of the flowmeter, always operate the instrument according to the usage precautions below.

**WARNING**

Do not open the inner panel while feeding power.

Do not modify and disassemble the unit.

Do not conduct wiring work with bare hands.

Do not work on installing and wiring with wet hands.

These actions may result in electrical shock or equipment damage.

Install a switch and fuse to isolate the unit from mains power.

Power supply from mains power can cause electric shock or circuit break-down.

Turn off mains power before conducting wiring work.

Wiring while power is applied can cause electric shock.

Ground the unit independently from power equipment.

(100 ohm or less ground resistance)

Operating the unit without grounding can cause electric shock or malfunction.

Do not use a fuse with different ratings.

Using a fuse other than the one specified can cause system failure, damage or malfunction.

⚠ CAUTION

1. Failure to comply with one or more of the following conditions may result in poor measurement performance or incorrect measurement values.
 - Use an appropriate power supply rated for the voltage range designated in the specifications.
 - Fill pipes entirely with water.
 - Be sure bubbles or particles that might interfere with ultrasonic waves are absent during measurement.
 - Position the transducer in accordance with the required straight pipe length.
 - Do not subject the transducer to vibration or mechanical shock.
 - Place the flowmeter unit, transducer and cable in a location without noise interference.
 - Use the equipment within the predetermined ambient temperature and humidity range.
 - Do not remove cable glands that are attached to the main unit. The cable glands are required to meet specification class. .
2. If the signal level is below the minimum detection requirement of the instrument, the LCD display of the main unit will display the R (no wave reception) alarm.
The D (disturbance) alarm is triggered when an abnormal measurement value is detected.
Note that in both cases the flowmeter may display the flow value preceding the alarm.
3. Be sure to use the instructions in the Manual when changing settings on the main flowmeter unit (maximum flow, integration units, etc.). Incorrect settings will result in poor performance or incorrect measurement values (output signals).
4. If this manual is lost, contact the nearest dealership.

Usage limitation

This product is not manufactured for applying to a system requiring safety directly involved human life as follows. Please contact your nearest Toshiba International Corporation representative if there is a possibility of using this product for such use.

- Main control systems of nuclear power plants, safety protection systems in nuclear facilities or other important systems requiring safety
- Medical control systems relating to life support

Warranty and Limitation of Liability

Toshiba International Corporation does not accept liability for any damage or loss, material or personal, caused as a direct or indirect result of the operation of this product in connection with, or due to, the occurrence of any event of force majeure (including fire or earthquake) or the misuse of this product, whether intentional or accidental.

Introduction

Thank you for selecting our Ultrasonic Flowmeter.

This Manual includes detailed explanations regarding safety cautions, structure, set up, operation, troubleshooting, and maintenance of the Ultrasonic Flowmeter.

Read this manual carefully before operation to ensure an adequate understanding of the equipment.

Proper use of the Operation Manual

The following points must be observed:

CAUTION

1. Carefully read the Manual. The contents of this Manual are very important and should be read completely.
2. Store the Manual in a safe location. The Manual is essential for appropriate operation of the equipment. Store the manual in a safe and accessible location. The storage location and person in charge should be determined after careful consideration.
3. Ensure that the Manual is supplied to the operator of the equipment. The representative or dealer of this equipment must provide this Manual to the user who will actually operate the equipment.
4. The Manual must be replaced if lost or damaged. If the Manual is lost, contact the representative. A new manual is available for purchase.
5. Ensure that the warning label is properly attached. If the warning label is illegible or has come off, contact the manufacturer to purchase a new label.

Precautions regarding the Manual

This Manual was written in accordance with the standard specifications of the original instrument.

In case of discrepancies between written specifications and approved drawings, the drawings should be given precedence.

Restrictions and precautions necessary to maintain the equipment

The following items must be observed in order to maintain the equipment.

CAUTION

1. Do not drop or bump the unit and the transducer.
2. Do not use the unit in environmental conditions (ambient temperature, ambient humidity) other than those prescribed in this manual.
3. Do not use the unit with a power supply other than the one prescribed in this manual.
4. Do not use damaged or worn-out cables (power cables, coaxial cables, signal cables).
5. The device contains high-voltage circuit boards. Never, under any circumstances, touch terminals or the inside of the device when the power is on.
6. The device is operated via the opened panel (display, keyboard) of the main flowmeter unit. Do not manipulate electrical circuits (printed circuit boards, electrical parts, etc.) inside the panel.
7. Under no circumstances attempt to modify or disassemble the instrument. Contact the manufacturer in the event of a malfunction.
8. Do not use the unit and/or accessories in restricted hazardous areas.

Handling Precautions

To obtain the optimum performance from the unit for years of continuous operation, observe the following precautions.



CAUTION

1. Do not store or install the unit in:
 - Places where there is direct sunlight.
 - Places where excessive vibration or mechanical shock occurs.
 - Places where corrosive atmospheres exist.
 - Places submerged under water.
2. Wire cables correctly and securely.
 - Be sure to ground at the main unit (grounding resistance 100Ω or less).
 - Avoid a common ground used with other equipment where earth current may flow. An independent ground is preferable
3. Select cable paths away from electrical equipment (motors, transformers, or radio transmitters), which causes electromagnetic or electrostatic interference.
4. If the inside of the main unit and transducers are wetted or humidified, it may cause insulation deterioration, which can result in fault or noise occurrence. So do not conduct wiring in the open air on rainy days.
 - Also, be careful not to wet down the converter and detector's terminal box even in the case of indoor wiring, and complete wiring work in a short period of time.
5. This product may cause interference to radio and television sets if they are used near the installation site. Use metal conduits etc. for cables to prevent this interference.

* We assume no responsibility for nonconformity caused by violation of precautions described in this manual or used in violation of the installation method and the operation method stipulated in a relevant ordinance or other regulations.

Trademarks

1. Windows is registered trademarks of Microsoft Corporation in the United States and/or other countries.
2. The official name of Windows is Microsoft® Windows® Operating System.
3. The official name of Windows XP is Microsoft® Windows XP Operating System.
4. The official name of Windows Vista is Microsoft® Windows Vista® Operating System.
5. The official name of Windows 7 is Microsoft® Windows® Operating System Windows 7.
6. Modbus® is a registered trademark of Schneider Electric.
7. All other marks and names are trademarks or registered trademarks of the respective owners.

Safety Precaution	1
Safety Symbols	1
Name of each part	2
Labels and attached place	3
Usage Precaution	6
Introduction	8
Proper use of the Operation Manual	8
Precautions regarding the Manual	8
Restrictions and precautions necessary to maintain the equipment	8
Handling Precautions	9

INDEX

1. Installation	13
How to install flowmeter system.	
1-1. Configuration	14
1-2. Installation and Wiring	16
1-2-1 Installation Procedure	16
1-2-2 Selection of transducer mounting position	18
1-2-3 Installation of the main unit	21
1-2-4 Wiring	23
1-2-5 Ground connection	29
1-2-6 Installation of power supply disconnecting device	30
1-2-7 Installation of DC power source	30
1-2-8 Cable wiring to the transducers	31
1-2-9 Transducer Installation (mounting by the V method)	34
1-2-10 Transducer Installation (mounting by the Z method)1 Installation	43
1-2-11 Gauge paper	54
1-2-12 Input parameter by commissioning software	55
2. Operation	61
How to operate main unit.	
2-1. Key operation	62
2-1-1 Basic operation	62
2-1-2 Contrast adjustment	63
2-1-3 LCD message	64
2-1-4 Protection release	64
2-2. Commissioning software (LF810Config)	65
2-2-1 Advanced setting	65
2-2-2 Contrast adjustment	66
2-2-3 Echo-form Viewer	67
2-2-4 Downloading internal Logged Data	68
2-2-5 Option	69
2-2-6 Language	70
2-3. Parameter	71
2-3-1 Site data	71
2-3-2 Flow units	73
2-3-3 Correction	74

2-3-4 Alarm operation	75
2-3-5 LCD display	77
2-3-6 Analog output	79
2-3-7 Contact output	81
2-3-8 Digital communication	83
2-3-9 Analog input	84
2-3-10 Log	85
2-3-11 Totalizing	86
2-3-12 Check function	88
2-3-13 System	90
2-4. Status/Error code	91
2-4-1 Status	91
2-4-2 Error code	92
3. Other	93
Maintenance, Specification or Measuring Principle.	
3-1. Maintenance and Inspection	94
3-1-1 Main unit and transducer maintenance and Inspection	94
3-1-2 Parts like reference	94
3-2. General Specifications	96
3-2-1 Overall	96
3-2-2 Main unit	97
3-2-3 Transducer	101
3-2-4 Optional parts	101
3-2-5 Type specification code	102
3-2-6 Dimensions	103
3-2-7 Digital communication specification	107
3-3. Principle of the ultrasonic flowmeter	118
3-3-1 Measurement Principle	118
3-3-2 Transmission and reflection methods	121
3-4. Appendix	122
3-4-1 Flow volume and average flow velocity	122
3-4-2 Pipe conditions and required straight length	123
3-4-3 Sound velocity & kinematics viscosity reference list	124
3-5. FAQ	126
3-5-1. Measured method	126
3-5-2. Measured fluids	128
3-5-3. Pipes	129
3-5-4. Installation location	130
3-5-5. Other	131
3-6. Trouble shooting	133
3-6-1. Main flowmeter unit and components	133
3-6-2. Measurement	133

1. Installation

1-1. Configuration

The Ultrasonic Flowmeter consists of the following primary components. Fig. 1-1-1 shows the interrelationship among each device.

Name	Q'ty	Description	Figure	Page
1. Main unit	1	Ultrasonic Flowmeter main unit	Fig. 3-2-6-1 Fig. 3-2-6-2	103 104
2. Transducer	2	Ultrasonic wave transmitter-receiver sensors	Fig. 3-2-6-3	105
3. Mounting fixtures	1set	Fixtures used to attach the transducers to a pipe	Fig. 1-2-9-15 Fig. 3-2-6-4 Fig. 3-2-6-5	38 106
4. Other	1 set	Epoxy adhesive (Transducer terminal sealant, Transducer coupling adhesive) Coupling for temporary installation	---	---

* Coaxial cable will be supplied if it is ordered.

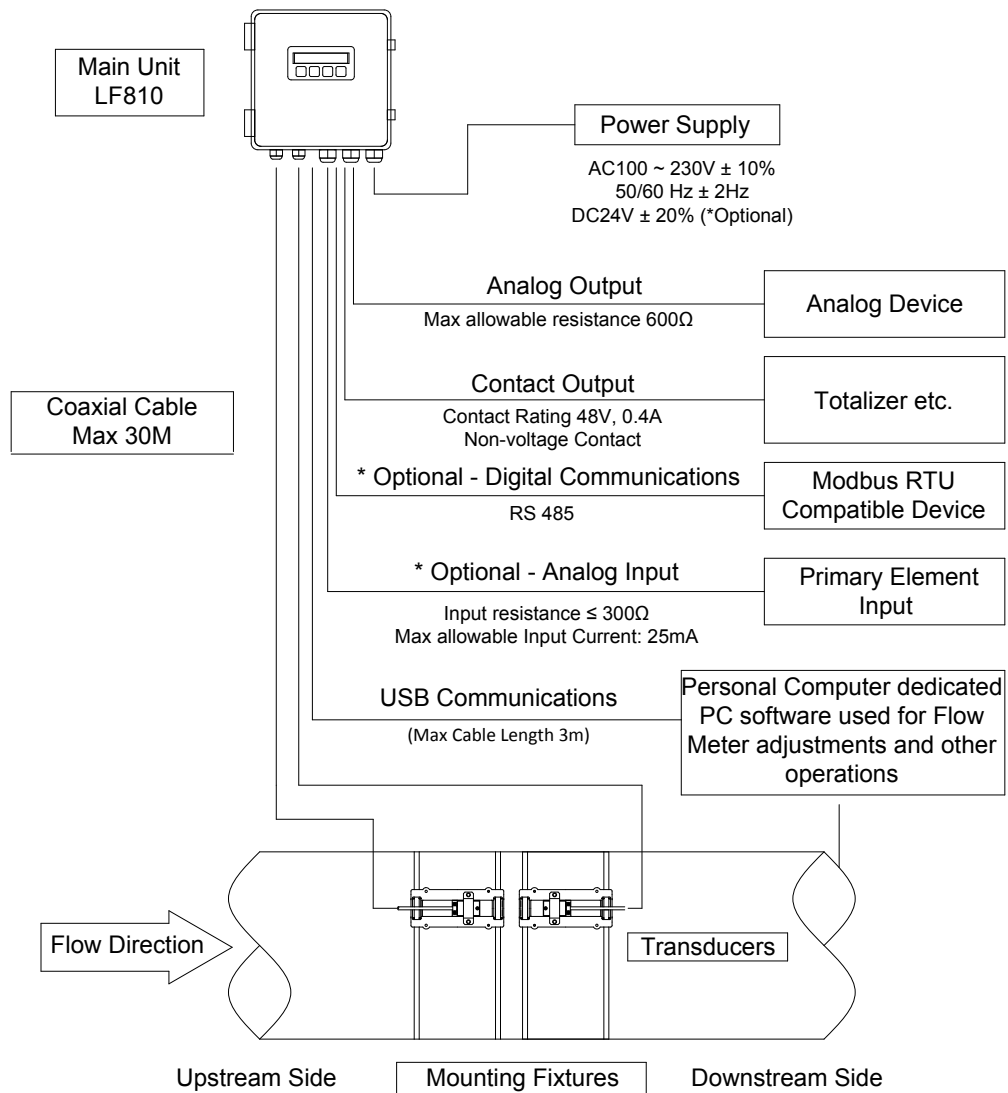

Fig. 1-1-1 Ultrasonic Flowmeter basic configuration

Notes

When used as an EC Directive compliant product

[For AC power source]

Install a power supply disconnecting device (switch or circuit-breaker) comply with the requirements prescribed by IEC60947-1 and IEC60947-3.

The specifications are as follows:



- The switch or circuit-breaker shall be included in the building installation.
- It shall be in close proximity to the flowmeter and within easy reach of the operator.
- It shall be marked as the switch or circuit-breaker for the flowmeter.

[For DC power source]

- Isolate the DC power source from the mains by means of reinforced insulation.

1-2. Installation and Wiring

When installing the Ultrasonic Flowmeter LF810, be sure to observe the conditions and cautions noted in each item below, and to perform the installation and wiring work correctly.

 DANGER
<ul style="list-style-type: none"> • Be sure to stop power supply to the main unit before performing wiring work to prevent electric shock. • Always connect the earth terminal to prevent electric shock.
 WARNING
<ul style="list-style-type: none"> • Make sure that the wiring is correct. Incorrect connections may result in damage to the flowmeter and connected equipment. • The flowmeter is not an explosion-proof device. Do not install the flowmeter in an atmosphere where any flammable or explosive gas is present.
 CAUTION
<ul style="list-style-type: none"> • Be sure to connect the earth terminal correctly, otherwise: The internal lightning arrester circuit cannot function correctly. (In the event a direct lightning strike is received, the lightning arrester will be unable to protect the flowmeter main unit.) (In the event an indirect lightning strike that exceeds the specification is received, the lightning arrester will be unable to protect the flowmeter main unit.) External noise may result in incorrect measurement. • After installation and wiring work, be sure to close the main unit cover securely and tighten the cable gland screws to prevent the entry of water and dust.

1-2-1 Installation procedure

(1) Installation procedure

The basic installation procedure is outlined below.

No.	Step	Procedure	Reference chapter
1	Selection of transducer mounting positions		1-2-2
2	Installation of the main unit	Installation and wiring	1-2-3 to 1-2-7
3	Parameter settings	(1) Pipe data	1-2-12 (8)
		(2) Sensor data, Cable length	2-3-1 (1)(2)(3)
		(3) Fluid data	
4	Confirmation of transducer mounting interval		1-2-12 (9) 2-3-1 (4)
5	Output settings	(1) Flow units	1-2-12 (11) 2-3-2
		(2) Totalized units	1-2-12 (11) 2-3-11
		(3) Alarm output	1-2-12 (12) 2-3-4
		(4) Analog output	1-2-12 (14) 2-3-6
		(5) Contact output	1-2-12 (14) 2-3-7
6	Cable connection to transducers		1-2-8
7	Temporary Installation of transducers	Use grease for temporary installation.	1-2-9 or 1-2-10
8	Connection of transducer cables to the main unit		1-2-4

9	Confirmation of main unit operation	The pipe should be filled with fluid.	1-2-12 (17)(18)
10	Permanent installation of transducers	Use adhesive for permanent installation.	1-2-9 or 1-2-10
11	Final confirmation of settings	Confirm using the PC setup software or the LCD display.	1-2-12 (17)(18)
12	Start measurement		

(2) Required tools for installation

The following tools are required for the installation work.

No.	Item name	Q'ty	Purpose
1	Grinder	1	For polishing the pipe surface
2	File	1	For polishing the pipe surface
3	Sandpaper	1	For polishing (finishing) the pipe surface
4	Hammer	1	For adjusting the transducer mounting positions
5	Knife (or cutter)	1	For cable end treatment
6	Scriber (or marker)	1	For marking the transducer mounting positions
7	Phillips-type (+) screwdriver	1	For wiring work
8	Slotted-type (-) screwdriver	1	For wiring work
9	Nippers	1	For cable cutting and wiring work
10	Scissors	1	For cable end treatment
11	Metal shears	1	For installing the metal fixtures (cutting the stainless steel bands)
12	Gloves	1	For installing the metal fixtures
13	Protective eyeglasses or goggles	1	For installing the metal fixtures
14	Tape measure	1	For confirming the transducer mounting interval
15	Gauge paper (Fig.1-2-11, Table 1-2-11)	As appropriate	For confirming the horizontal line to the pipe
16	Alcohol (for cleaning)	As necessary	For cleaning the pipe and washing away grease
17	Rags	As necessary	For cleaning the pipe
18	Paint	As necessary	For repairing the pipe

1-2-2 Selection of transducer mounting positions

<p>⚠ WARNING</p> <ul style="list-style-type: none"> • The flowmeter is not an explosion-proof device. Do not install the flowmeter in an atmosphere where any flammable or explosive gas is present.
--

(1) Mounting position

The utmost care should be taken when mounting the transducers, as the Ultrasonic Flowmeter performance is greatly affected by the transducer mounting accuracy.

- 1) Mount the transducers in a position that is filled with fluid even when the flow is stopped.
- 2) In general, the minimum straight pipe lengths noted in Chapter 3-4-2 “Pipe conditions and required straight pipe length” are required on the upstream and downstream sides from the transducer mounting position. Refer to these standards when selecting the position.
- 3) Select a pipe position with minimum flow obstruction. Contact TOSHIBA International Corporation when circumstances require installation in a location with a pump, valve, gradually widening pipe, merger pipe, or other flow-disrupting element either at the upstream or downstream side.
- 4) When selecting the position, avoid locations that may have air pockets at the top or sedimentation at the bottom of the measured pipe. (Fig. 1-2-2-1) In addition, avoid joints such as flanges and welding areas, and select a portion of the pipe with as smooth an outer surface as possible. (Fig. 1-2-2-2)
- 5) Select a location with an ambient temperature of -20 to +60°C. Also, do not place the transducers near a heating element, and avoid exposure to direct sunlight.
- 6) Long-term exposure to rain and wind may speed deterioration in performance. Therefore, avoid use in these environments if possible.

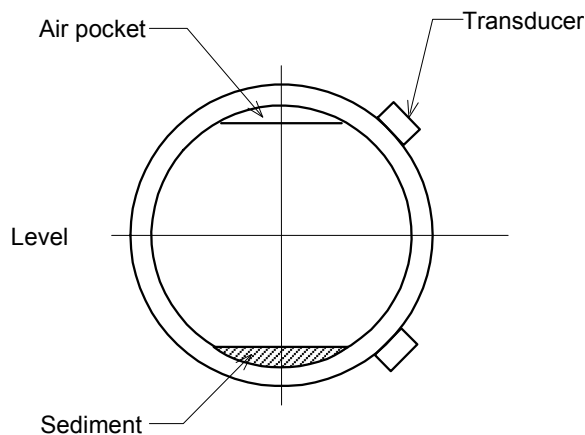

Fig.1-2-2-1 Transducer Mounting Position

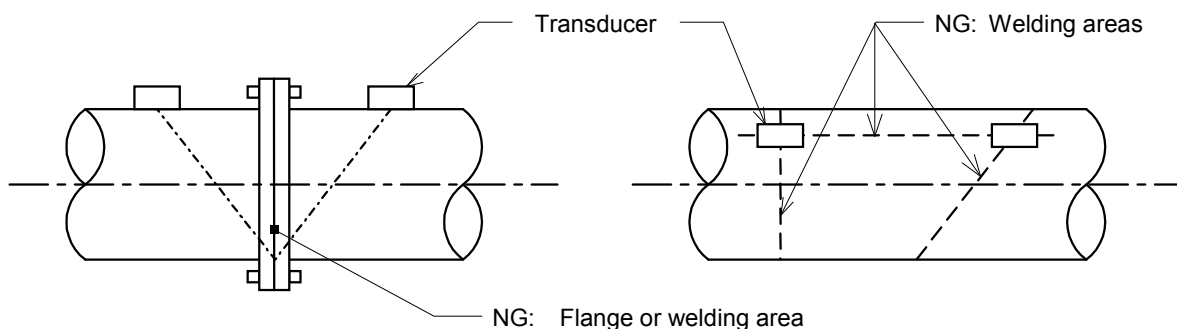

Fig.1-2-2-2 Unsuitable (NG) transducer mounting positions

a. Areas not filled with fluid

Measurement may not be possible in areas not filled with fluid.

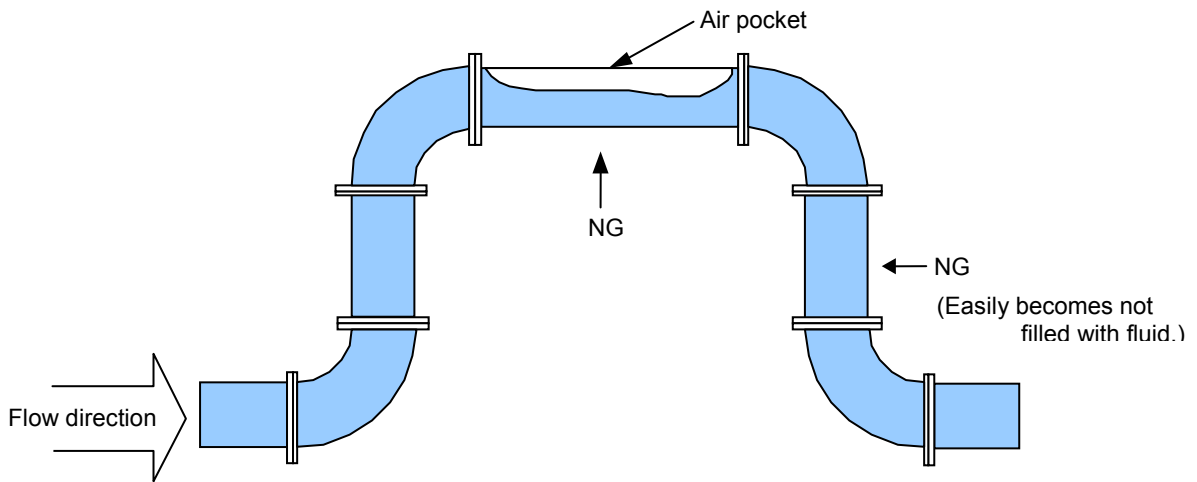

Fig.1-2-2-3 Air pockets

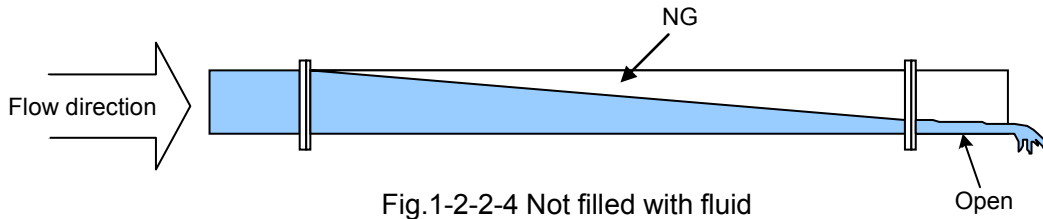

Fig.1-2-2-4 Not filled with fluid

b. Sedimentation

Sedimentation or other accumulated matter at the transducer location may result in measurement errors.

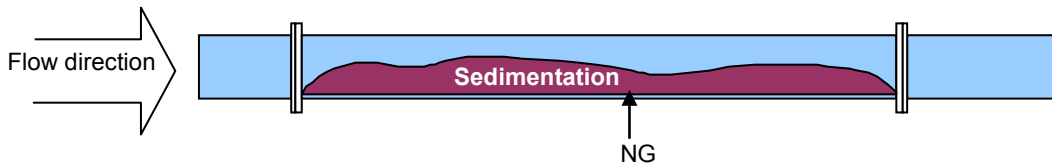

Fig.1-2-2-5 Sedimentation

c. Drawn-in air

Measurement may not be possible when air is sucked into the transducer location.

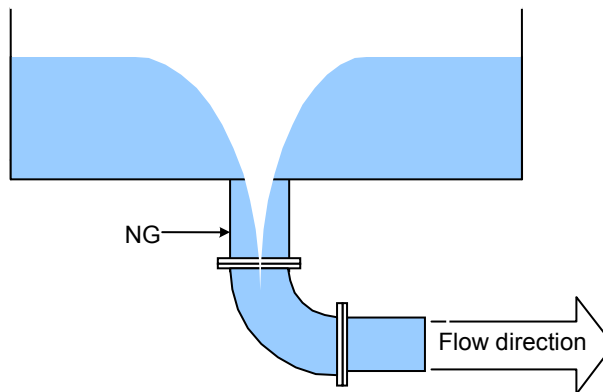
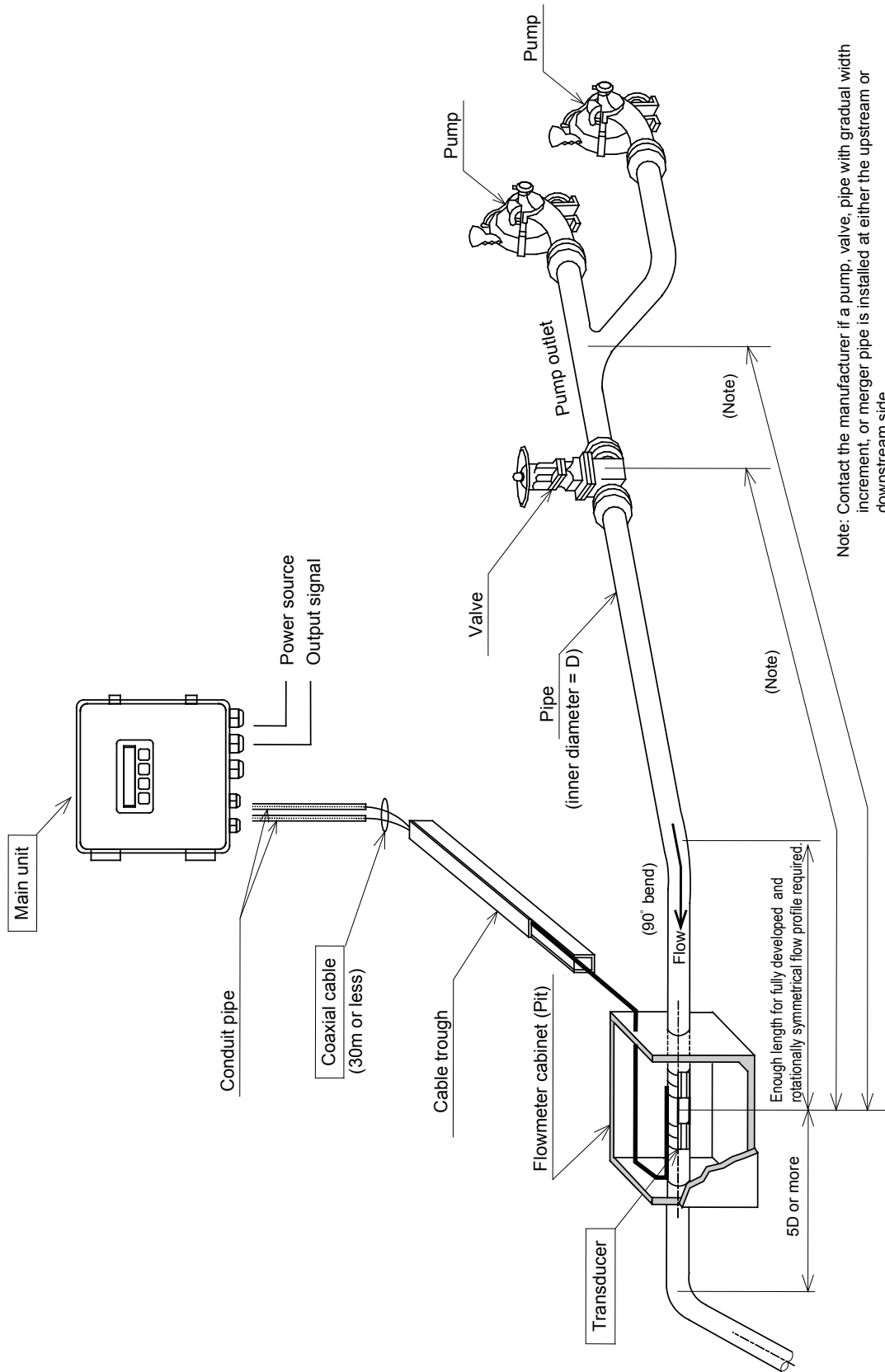

Fig.1-2-2-6 Drawn-in air



Note: Contact the manufacturer if a pump, valve, pipe with gradual width increment, or merger pipe is installed at either the upstream or downstream side.

Fig. 1-2-2-7; Ultrasonic Flowmeter Positioning Example

1-2-3 Installation of the main unit

<p>⚠ WARNING</p> <ul style="list-style-type: none"> • The flowmeter is not an explosion-proof device. Do not install the flowmeter in an atmosphere where any flammable or explosive gas is present.
<p>NOTE</p> <ul style="list-style-type: none"> • In case of complying with EC Directives, do not install the flowmeter at an altitude higher than 2000 m.

(1) Installation location

Consider the following conditions when selecting the location to install the main unit.

- 1) Select a location with an ambient temperature of -10 to +50°C. Also, do not place the main unit near a heating element, and avoid exposure to direct sunlight.
- 2) Select a location that is not exposed to wind and rain for long periods of time.
- 3) Select a location without excessive dust or a corrosive atmosphere.
- 4) Select a location that enables easy inspections and maintenance.
- 5) The length of the coaxial cable connecting the main unit and the transducers should not exceed 30 m.
- 6) Select a location where the main unit is not subject to inductive interference from power equipment or wiring (including power lines).

(2) Installation of the main unit

- 1) The main unit can be mounted to a wall, or to a DN50mm stand pipe using a mounting plate and U bolts (option). The mounting plate (option) can mount to a wall, too. Secure the main unit firmly in either case.
- 2) Secure sufficient area around the unit to facilitate inspections and maintenance.

[Installation by mounting feet (accessory)]

- 3) Fix the mounting feet on the back of main unit by 4 screws (M4). Use 4 bolt (M5) or similar fixture to secure the main unit to a wall.

[Installation by mounting plate (option)]

- 4) Fix the mounting plate on the back of main unit by screw (M4).
- 5) Use 4 bolts (M10) or similar fixture to secure the main unit to a wall.
Use 2 U bolts to secure the main unit to a DN 50mm stand pipe.

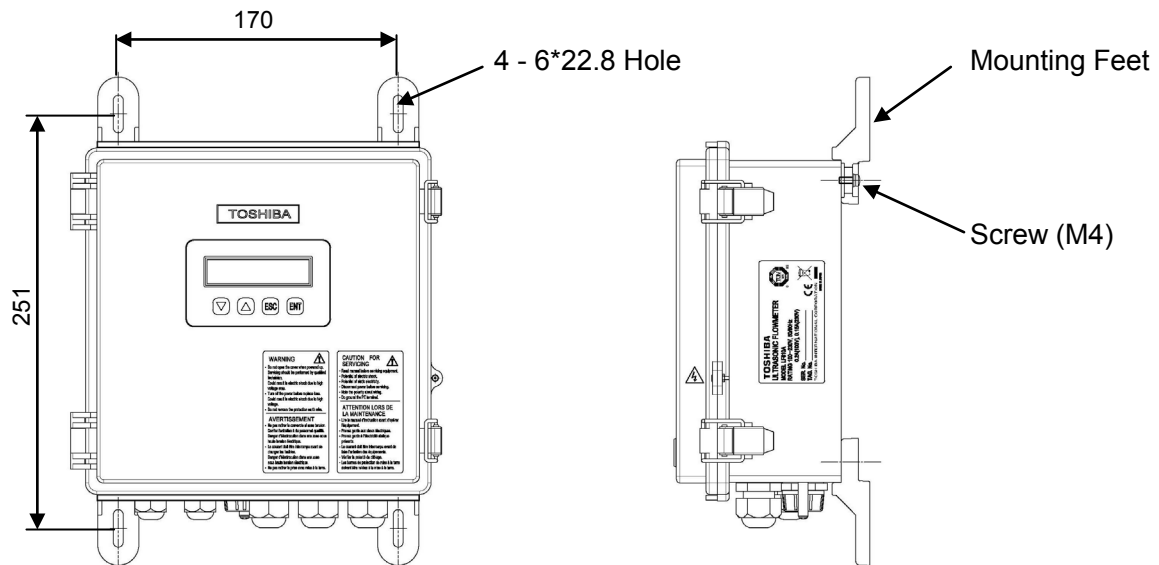

Fig.1-2-3-1 Wall mounting using 'Mounting Feet'

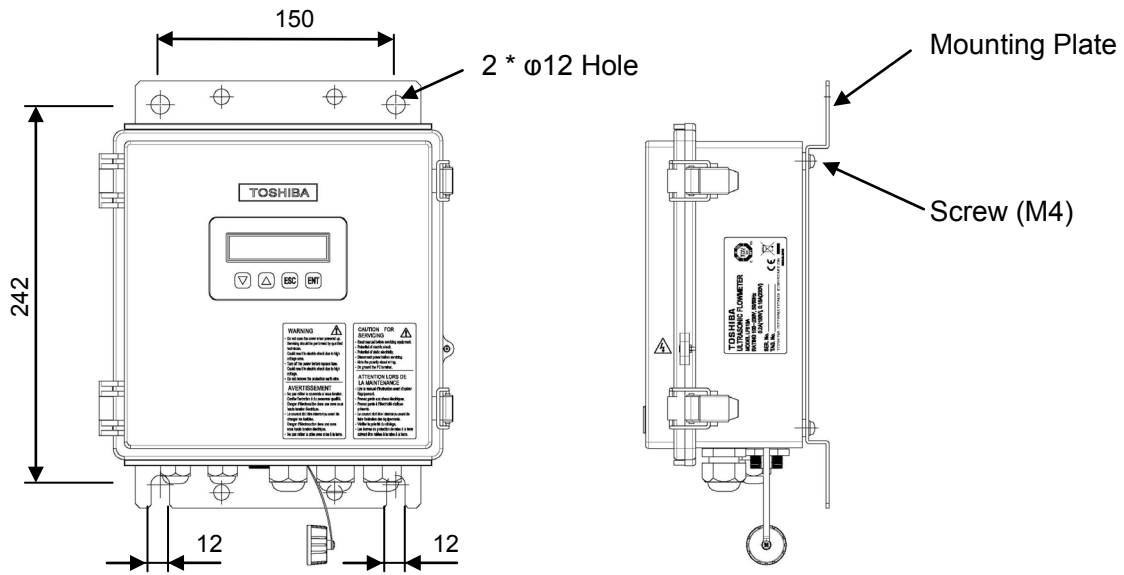

Fig.1-2-3-2 Wall mounting utilizing 'SS Mounting Plate'

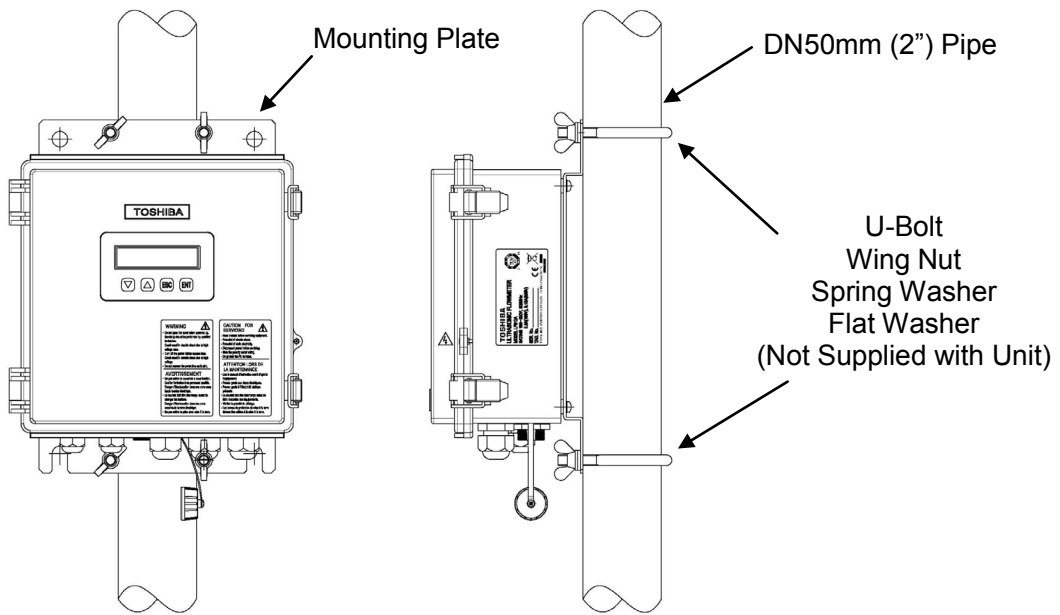



Fig.1-2-3-3 DN50 (2") pipe mounting utilizing 'SS Mounting Plate'

1-2-4 Wiring

 DANGER
• Be sure to stop power supply to the main unit before performing wiring work to prevent electric shock.
 WARNING
• Make sure that the wiring is correct. Incorrect connections may result in damage to the flowmeter and connected equipment. Please refer to Chapter 3-2-2 for the input/output specifications.

(1) Notes on wiring

- 1) The cable gland holes on the bottom surface of the main unit case are blocked by seal pins prior to shipment from the factory. Remove the seal pins from the required locations and perform the wiring work.
Use tightening torque of approximately 1.5 N·m when mounting the cable glands.
- 2) Turn off the main power before performing wiring work.
- 3) Separate the coaxial cable connecting the main unit and the transducers from power lines, and position the cable to avoid proximity to power equipment.
- 4) Refer to Fig. 1-2-4-1, Fig. 1-2-4-2 and Table 1-2-4 for wiring connections between the main unit and external equipment.
- 5) Connect the coaxial cable so that the transducer on the upstream side is connected to the “Up” side connector on the main unit, and the transducer on the downstream side is connected to the “Down” side connector on the main unit.
- 6) Always use a separate instrumentation power source as the power source, and avoid sharing with a power source used to power equipment.
- 7) Be careful of polarity when performing wiring work.

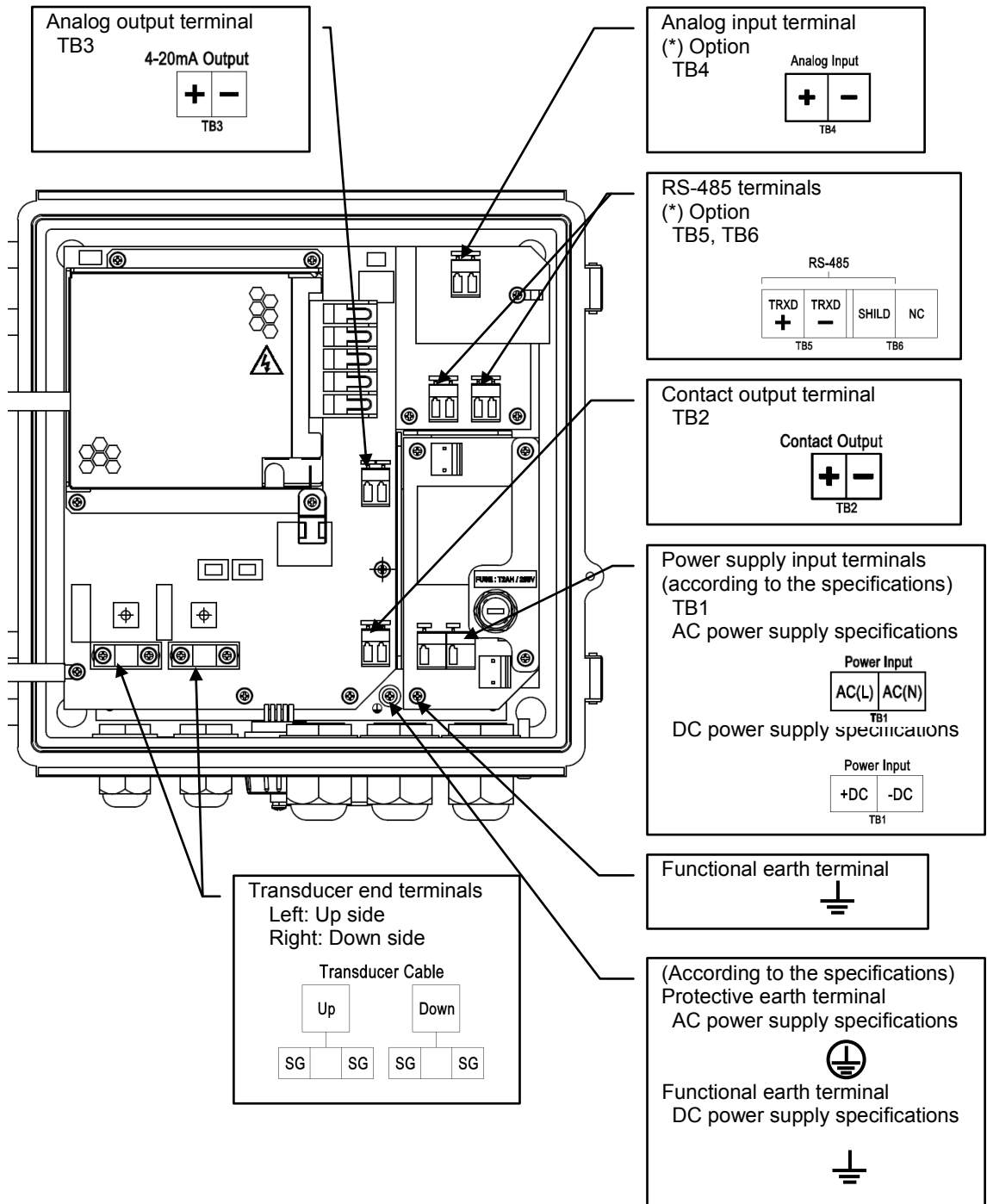

Fig. 1-2-4-1 Internal connection terminal block of main unit

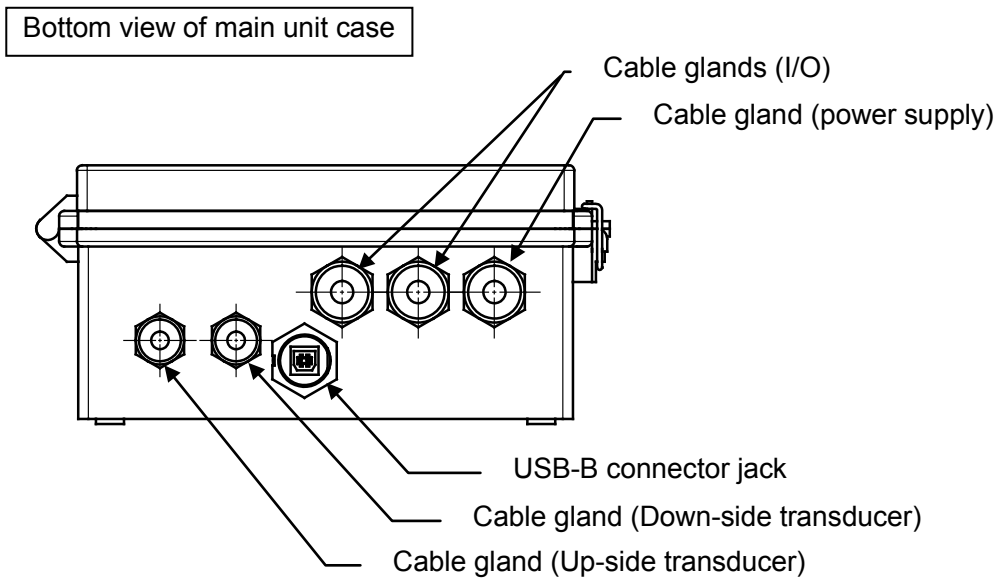

Fig. 1-2-4-2 External wiring

Table 1-2-4 Terminals for external connection

Functions may be limited by the specifications or settings. Be careful of the wiring polarity.

Name	Connection	Instruction
Power Input AC-IN(*1) L,N	TB1	AC power supply input. Connect "N" to the neutral (grounded) side, and "L" to the live (non-grounded) side.
Power Input DC-IN(*1) +,-		DC power supply input.
Protective Earth(*1)	PE terminal	PE terminal should be connected to earth of AC power source.
Functional Earth(*1)	FE terminal	FE terminal should be connected to earth of DC power source.
Contact Output (*2) +,-	TB2	Contact output. The output contents can be selected from the following nine items. (1) Forward flow totalized value, (2) Reverse flow totalized value, (3) No received signal (ROFF) alarm, (4) Breakdown (B.D.) alarm, (5) ROFF or B.D. alarm, (6) Upper limit alarm, (7) Lower limit alarm, (8) Forward flow identification, (9) Reverse flow identification
4-20mA Output +,-	TB3	Analog output.
Analog Input (*3) +,-	TB4	Analog input.
RS-485 (*4) +,-,Shield	TB5 TB6	RS-485 (MODBUS-RTU) output.
Transducer Cable Up,Down	-	Transducer connections. Connect the transducer on the upstream side to "Up", and the transducer on the downstream side to "Down".

(*1) Select AC or DC according to the specifications. (Change the label.)

(*2) The maximum contact output capacity is 48Vdc, 0.4 A. Do not connect an AC signal.

(*3) Analog input is an optional specification.

(*4) Digital communication is an optional specification.

(2) Power cable wiring

- 1) Use a power cable with a nominal cross-section area of 14-18 AWG.
- 2) Install per the National Electrical Code for the US (NEC, ANSI/NFPA 70) and the Canadian Electrical code for Canada (CEC, CAN/CSA-C22.1) In case of complying with EC Directives, use a cable that complies with the requirements prescribed by IEC60227 or IEC60245
- 3) Treat the cable ends on main unit side as follows.
 - Remove 6 mm of the covering from the end of the wires (power-line).
 - Lengthen the earth wire more than 10mm than the wires of power-line, attach an M4 crimped terminal.

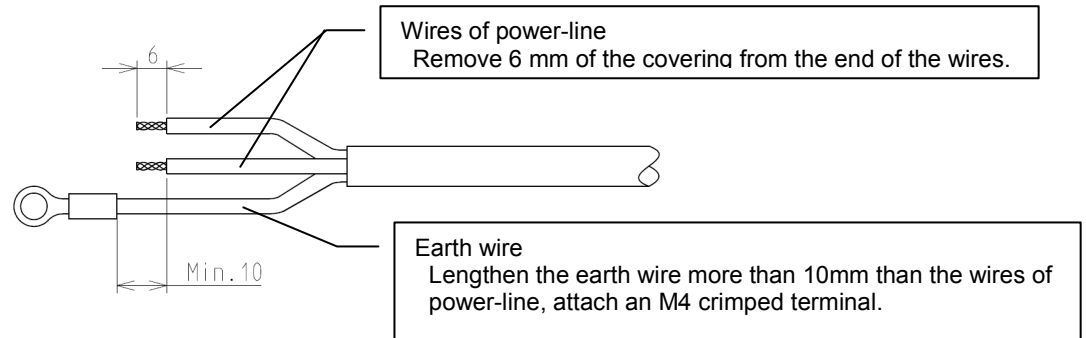

Fig.1-2-4-3 End treatment of power line

- 4) For wiring connection to the terminal block, press the operation lever of the terminal block to open the clamp, and insert the wire.
- 5) Secure the crimped terminal of the earth wire firmly to the protective earth terminal. When using DC specifications, connect to the functional earth terminal.

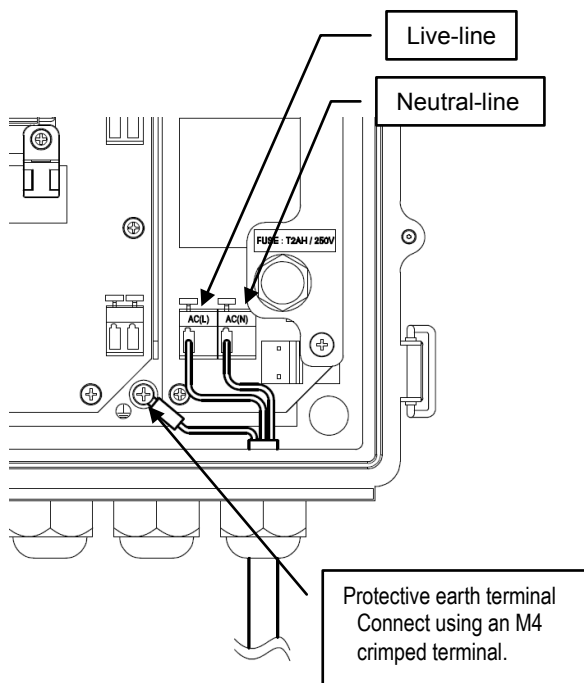

Fig.1-2-4-4 AC power supply connection

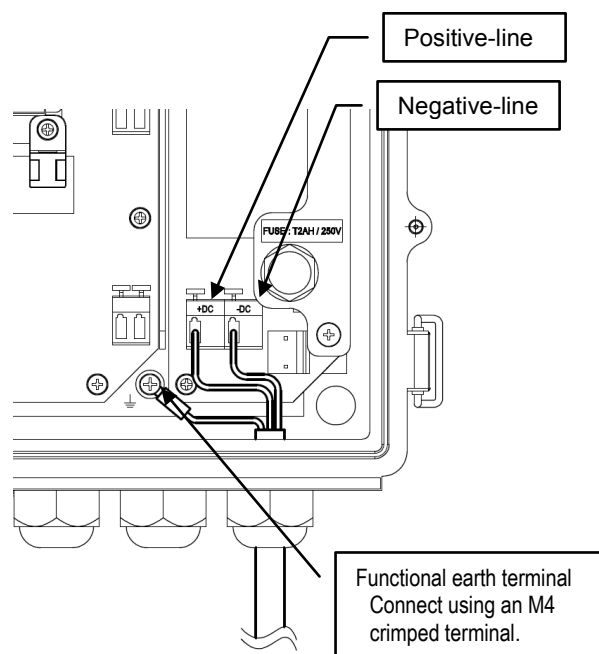

Fig.1-2-4-5 DC power supply connection

(3) Transducer cable wiring

- 1) In case of complying with EC Directives, use a coaxial cable (RG-223/U) for the wiring between the main unit and the transducers.
- 2) Separate the coaxial cable connecting the main unit and the transducers from power lines, and position the cable to avoid proximity to power equipment.
- 3) The cables between the transducers and the “Up” and “Down” side terminals of the main unit should be the same length.
- 4) Treat the cable ends on the main unit side as follows.
 - Remove 15 mm of the outer sheath from the end of the cable.

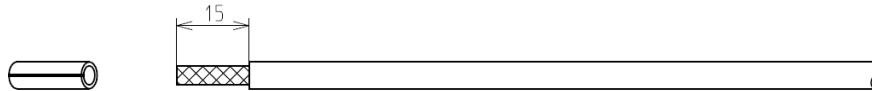

Fig. 1-2-4-5 Cable end treatment (1)

- Fold back the outer shield and trim it to a length of 10 mm.



Fig. 1-2-4-6 Cable end treatment (2)

- Remove the inner sheath so that 8 mm remains as shown in the figure.



Fig. 1-2-4-7 Cable end treatment (3)

- 5) Connect the coaxial cables from the upstream-side transducer to the “Up” side terminal and from the downstream-side transducer to the “Down” side terminal.

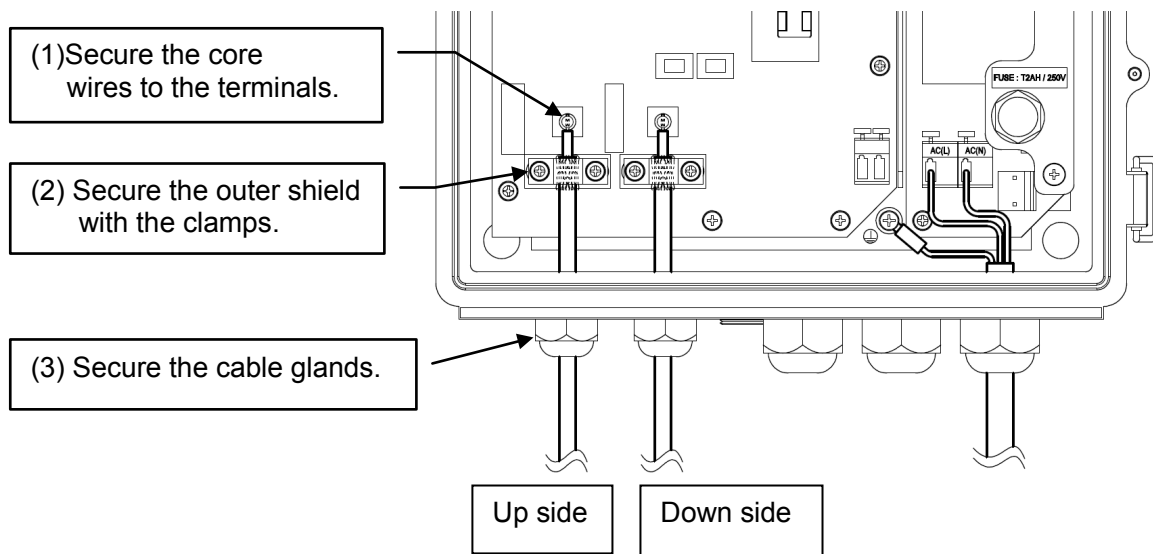

Fig. 1-2-4-8 Transducer cable wiring diagram

(4) Input/output signal (I/O) cable wiring

- 1) Use a signal cable with a nominal cross-section area of 0.75 to 2 mm² and an outer diameter of $\varnothing 6$ to $\varnothing 12$ mm. Use a multi-core cable as necessary.
- 2) For wiring connection to the terminal block, remove 6 mm of the covering at the end of the cable, press the operation lever of the terminal block to open the clamp, and insert the signal cable to connect the cable.
- 3) . In order to prevent wires from touching the circuit board, tie the wires with a plastic tie (see Fig. 1-2-4-9).
- 4) The figure below shows an example of the analog output and contact output wiring.

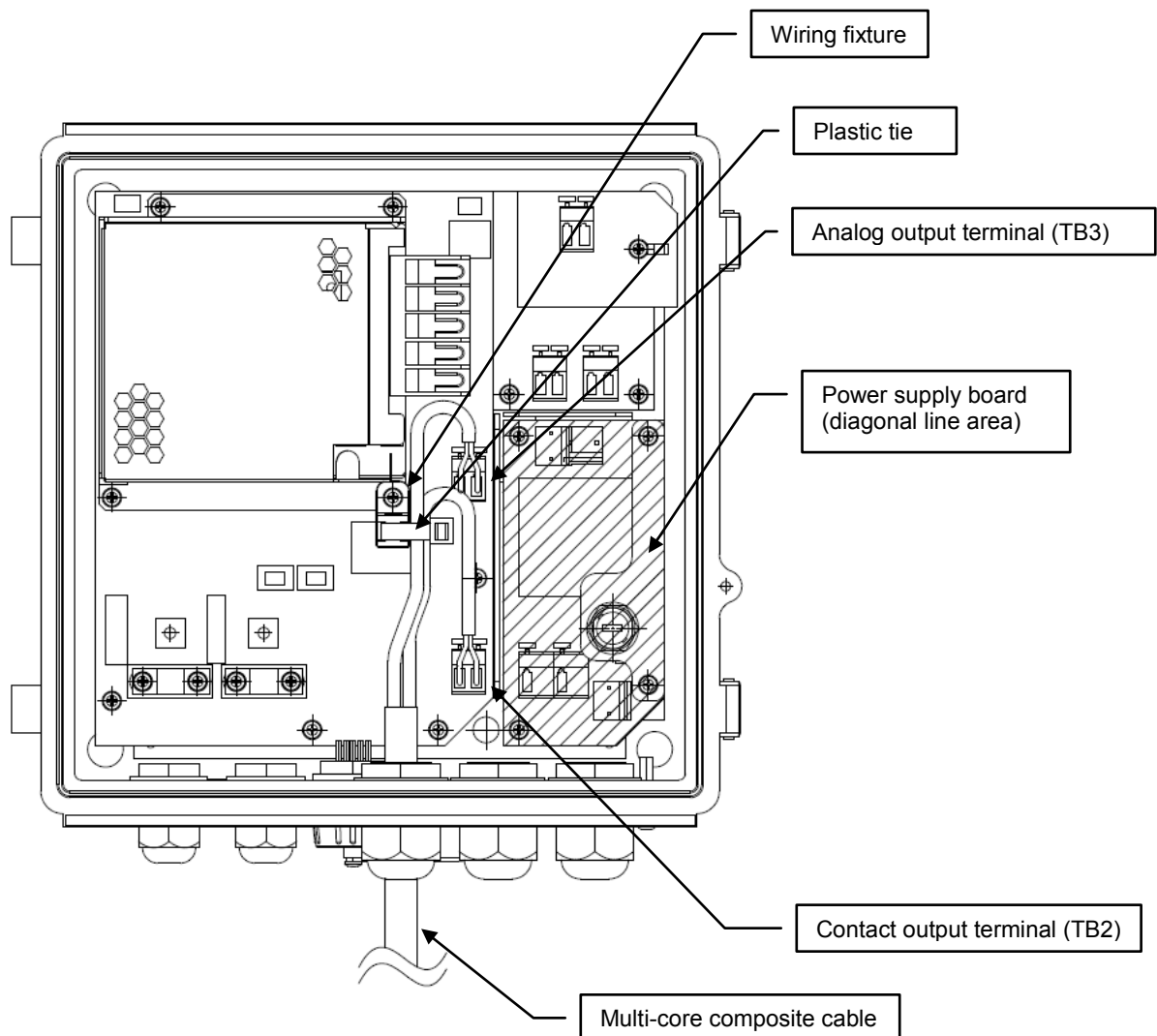



Fig. 1-2-4-9 Example of input/output signal (I/O) cable wiring

1-2-5 Ground connection

 DANGER
<ul style="list-style-type: none">• Be sure to stop power supply to the main unit before performing ground connection work to prevent electric shock.
 CAUTION
<ul style="list-style-type: none">• Be sure to connect the earth terminal correctly (grounding resistance 100Ω or less), otherwise: The internal lightning arrester circuit cannot function correctly. (In the event a direct lightning strike is received, the lightning arrester will be unable to protect the flowmeter main unit.) (In the event an indirect lightning strike that exceeds the specification is received, the lightning arrester will be unable to protect the flowmeter main unit.) External noise may result in incorrect measurement.

1-2-6 Installation of power supply disconnecting device

**DANGER**

- Be sure to stop power supply to the system before installing this device to prevent electric shock.

In case of complying with EC Directives when using an AC power-type main unit, install a power supply disconnecting device (switch or circuit-breaker) that complies with the requirements prescribed by IEC60947-1 and IEC60947-3.

The specifications are as follows:

- a) The switch or circuit-breaker shall be included in the building installation.
- b) Install the disconnecting device in close proximity to the equipment and within easy reach of the operator.
- c) Clearly mark it as the disconnecting device for the flowmeter.

NOTE

- The required ratings for the disconnecting device are 250 V, 10 A.

1-2-7 Insulation for DC power source

In case of complying with EC Directives when using a DC power-type main unit, isolate the DC power source from the mains by means of reinforced insulation.

1-2-8 Cable wiring to the transducers

The procedure for wiring the cables to the transducers is described below.

(1) Cable preparation

Prepare coaxial cables (RG-223/U) of the required length.

<p>NOTE</p> <ul style="list-style-type: none"> • The cables on the “Up” and “Down” sides should be the same length. Using cables with different lengths will affect the measurement accuracy. • Maximum cable length is 30m.

(2) Cable end treatment

- 1) Pass the transducer-side end of the cable through the supplied protective tube.

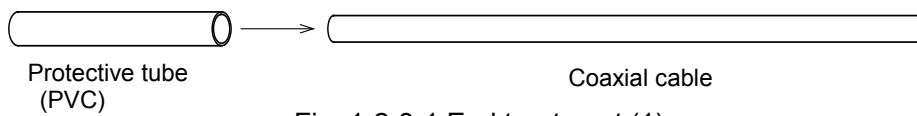

Fig. 1-2-8-1 End treatment (1)

- 2) Remove 15 mm of the outer sheath from the end of the cable.



Fig. 1-2-8-2 End treatment (2)

- 3) Fold back the outer shielding and trim it to a length of 10 mm.

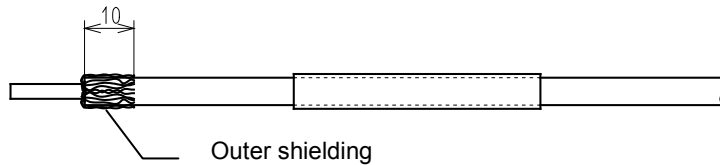

Fig. 1-2-8-3 End treatment (3)

- 4) Remove the inner sheath so that 3 mm remains as shown in the figure.

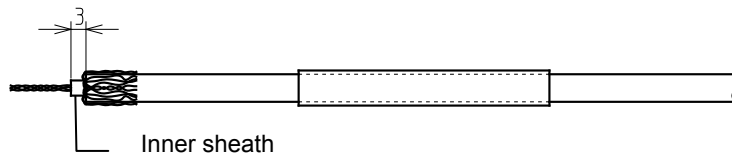

Fig. 1-2-8-4 End treatment (4)

(3) Cable connection

CAUTION

- After connecting the cables, make sure that the wires are not short-circuited. If the wires are short-circuited, the transducer will not operate correctly.

- 1) Using a Phillips-type (+) screwdriver, remove the transducer cover.
- 2) Using a Phillips-type (+) screwdriver, loosen the two clamp screws and the terminal screw, and insert the prepared cable into the transducer through the hole in the side of the transducer case.
- 3) Align the outer shielding of the cable with the GND-side terminal, and tighten the clamp to fix the cable. Next, tighten the terminal screw to fix the core conductor.
- 4) Slide the protective tube for the transducer case, and insert the tip of protective tube in the case hole to a length of about 2 to 3mm.
(If difficult, loose the clamp (GND-side terminal), and retry it.)
- 5) Tighten the clamp over the protective tube to fix the cable. Be careful not to short-circuit the wires at this time.

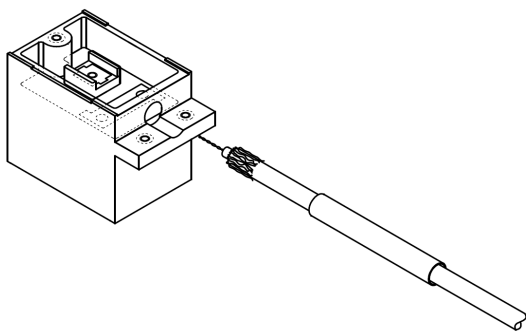

Fig. 1-2-8-5 Cable connection (1)

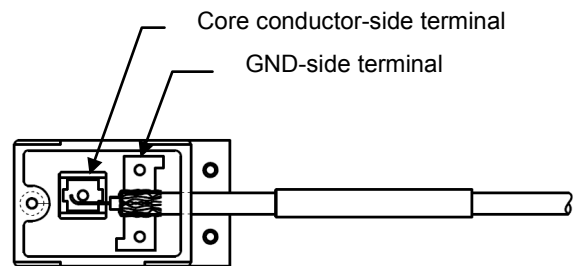

Fig. 1-2-8-6 Cable connection (2)

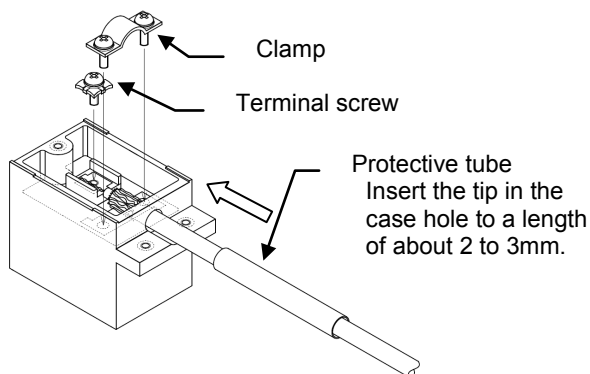

Fig. 1-2-8-7 Cable connection (3)

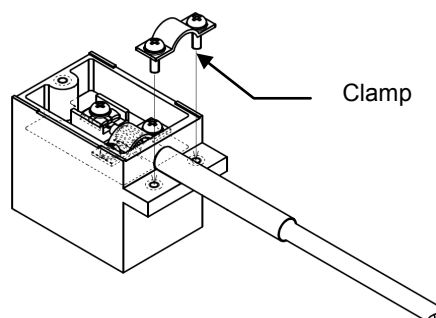

Fig. 1-2-8-8 Cable connection (4)

(4) Adding Adhesive to Sensor Housing

<p>⚠ CAUTION</p> <ul style="list-style-type: none"> • Perform the work carefully, and do not touch the adhesive with bare hands, as this may result in a rash or inflammation.
<p>NOTE</p> <ul style="list-style-type: none"> • Fill up the terminal area with the adhesive completely. Insufficient filling affects waterproofing performance.

- 1) Squeeze out equal amounts of the epoxy adhesive (3M Epoxy 2216 B/A) resin and hardener onto a clean sheet, and mix together thoroughly using the supplied spatula.
- 2) Apply the adhesive over the entire terminal area, and attach the cover with the screw. Perform the adhesive filling work within 20 minutes after mixing the adhesive. The filled adhesive gels and hardens in approximately 40 minutes.

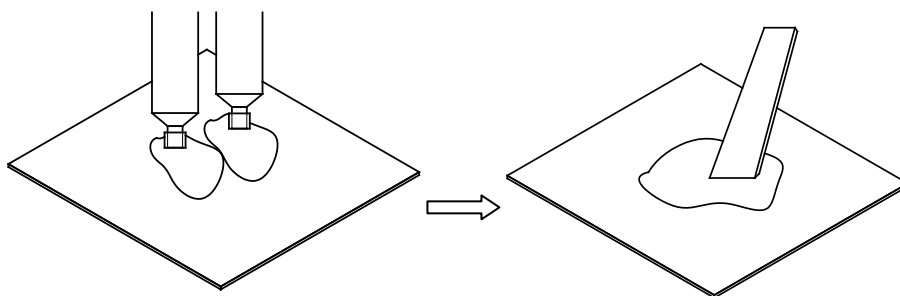

Fig. 1-2-8-9 Mixing the adhesive

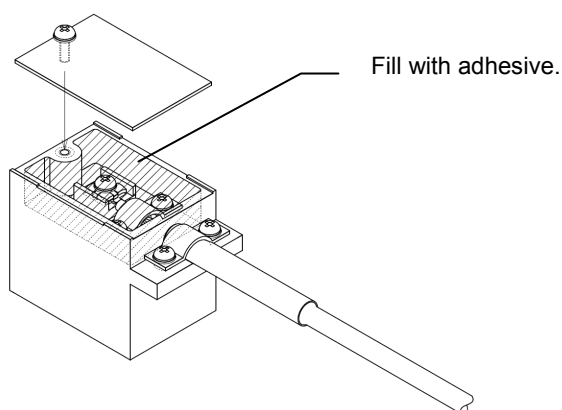

Fig. 1-2-8-10 Adding Adhesive to Sensor Housing

1-2-9 Transducer installation (mounting by the V method)

The procedure for mounting the transducers using the V method (reflection method) is described below. Be sure to confirm the transducer mounting interval (F-DIST) before performing this work. Please refer to Chapter 2-2-3 (4) for the F-DIST confirmation method.

(1) Clean the pipe to be measured

Clean the pipe to facilitate gauge paper attachment and marking on the pipe.

(2) Using gauge paper, mark a horizontal line on the pipe.

Prepare the gauge paper. For details on the gauge paper, please refer to Chapter 1-2-11.

- 1) Wrap gauge paper closely around the pipe, and make sure the overlapping paper is squared on both edges ("A").
- 2) Mark the gauge paper by drawing a line between points "B" on both sides of the paper where the overlap ends.

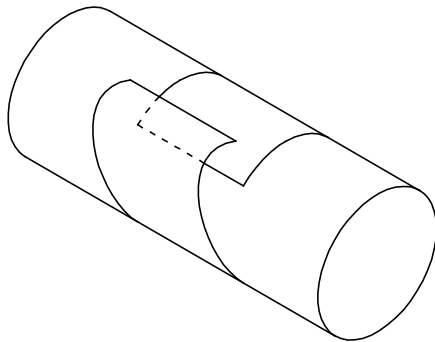

Fig. 1-2-9-1 Gauge paper (1)

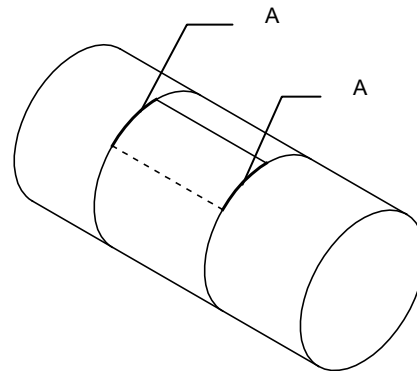

Fig. 1-2-9-2 Gauge paper (2)

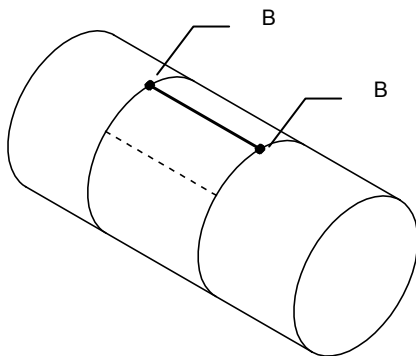



Fig. 1-2-9-3 Gauge paper (3)

	<p>WARNING</p> <ul style="list-style-type: none"> • Do not mount transducers on top and bottom of pipe.
---	---

Remove the gauge paper from the pipe, align the mark "B" with the square edge of the paper, and fold the paper in half, making a crease. (Divide the pipe circumference in half.)

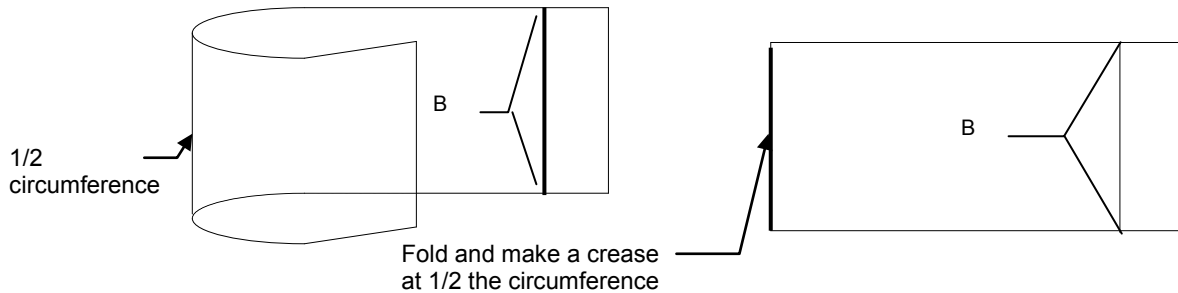

Fig. 1-2-9-4 Gauge paper (4)

- 3) Wrap the creased gauge paper around the pipe again. Make sure the overlapping paper is squared on both edges ("A"), and then fix the paper using adhesive tape.
- 4) Rotate the gauge paper around the pipe and move the crease to the transducer installation position.

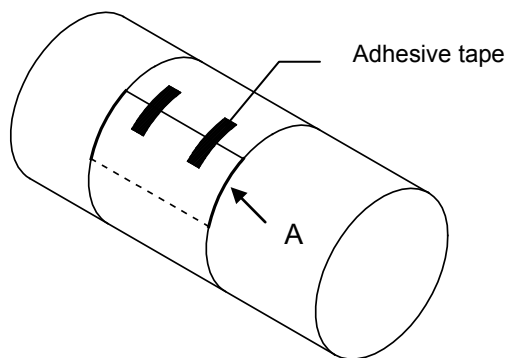

Fig. 1-2-9-5 Gauge paper (5)

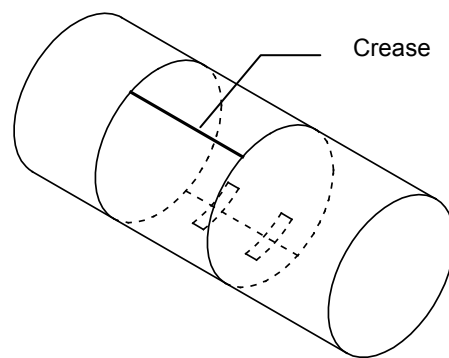

Fig. 1-2-9-6 Gauge paper (6)

- 5) Using a pencil or marking pen, extend the crease line outward from each edge of the gauge.
- 6) Remove the gauge paper and fill in the line between the two marking lines.

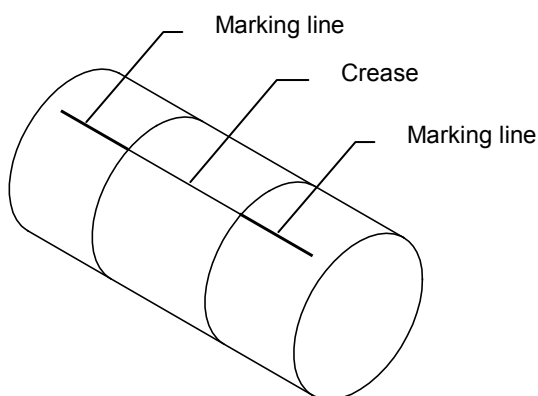

Fig. 1-2-9-7 Marking line (1)

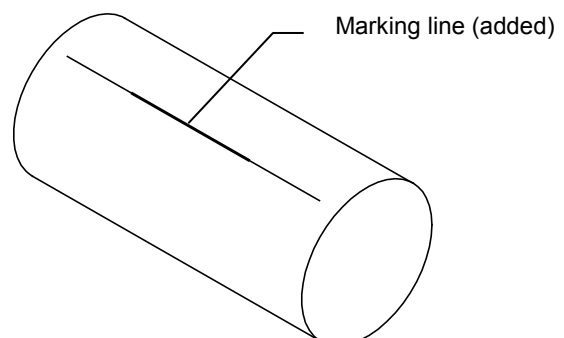

Fig. 1-2-9-8 Marking line (2)

(3) Polish the transducer installation positions.

- 1) Determine a reference point on the marking line, and mark the reference point on the pipe.
- 2) Make another mark on the pipe at the transducer mounting interval (F-DIST) from the reference point mark. Reference point of F-DIST is head of each transducers.

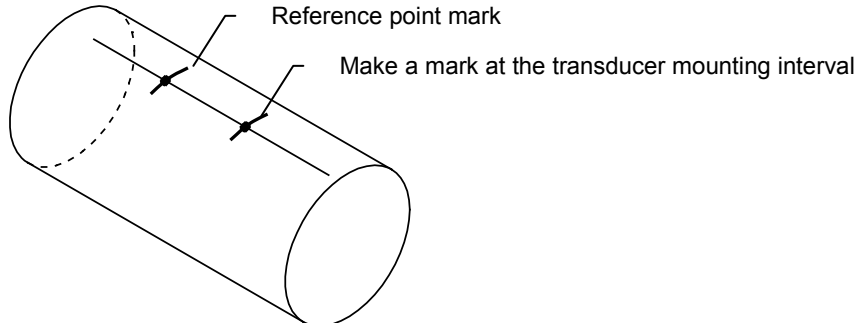

Fig. 1-2-9-9 Transducer mounting interval marks

- 3) Temporarily place a transducer holder at the reference point, and mark a range slightly larger than the transducer size.
 - 4) After marking the range, use sandpaper to polish the transducer mounting area as necessary to remove any bumps or unevenness.
 - 5) Perform the same procedure and polish the mounting surface for the other transducer as well.
- * If polishing is insufficient and the surface remains uneven, the transmittance of the ultrasonic waves from the transducer will become weak.*

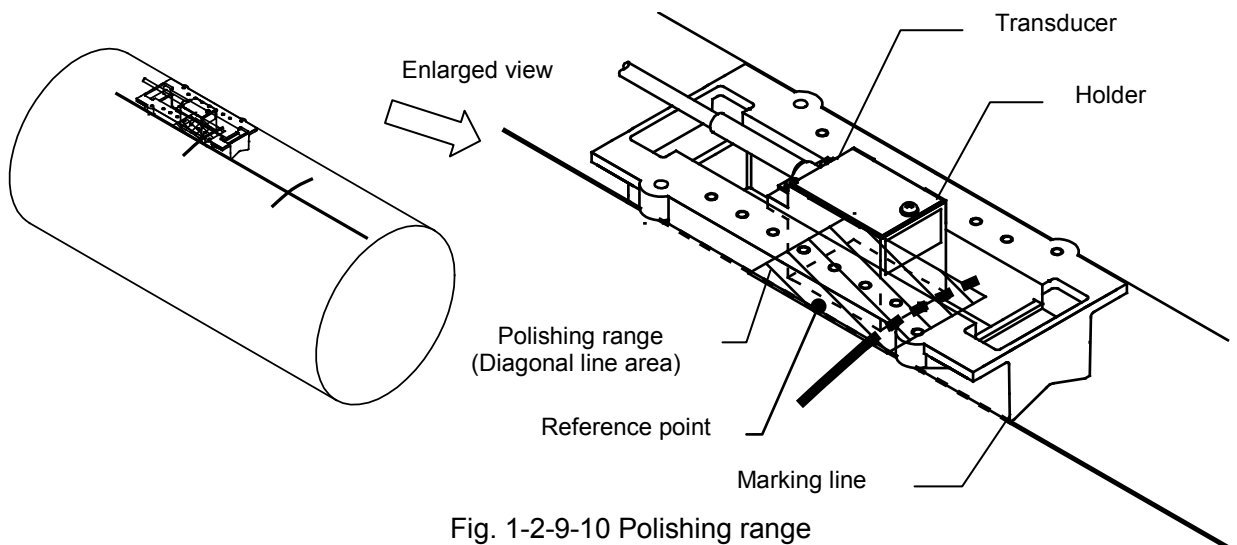

Fig. 1-2-9-10 Polishing range

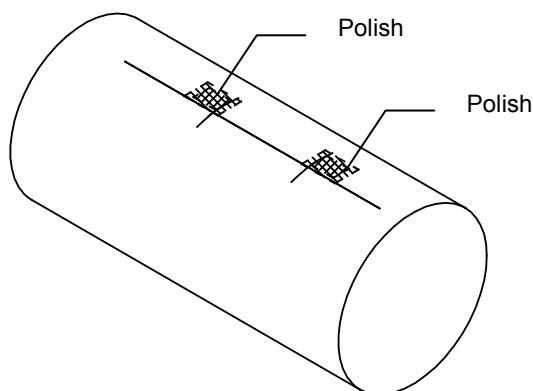

Fig. 1-2-9-11 Polishing the mounting positions

(4) Install the transducer holders

The number of transducer holders will be different according to the transducer mounting interval (F-DIST). When the transducer mounting interval (F-DIST) is less than 50 mm, two transducers can be mounted using a single transducer mounting fixture. When the transducer mounting interval (F-DIST) is 50 mm or more, use two transducer mounting fixtures.

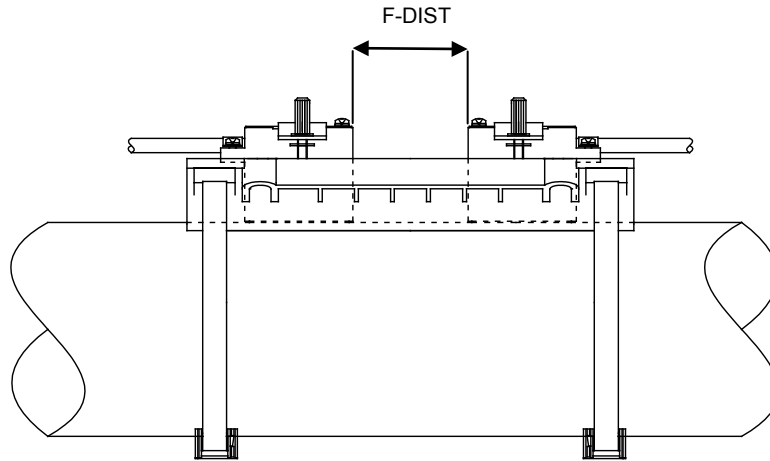

Fig. 1-2-9-12 Mounting method for a transducer mounting interval (F-DIST) of less than 50 mm

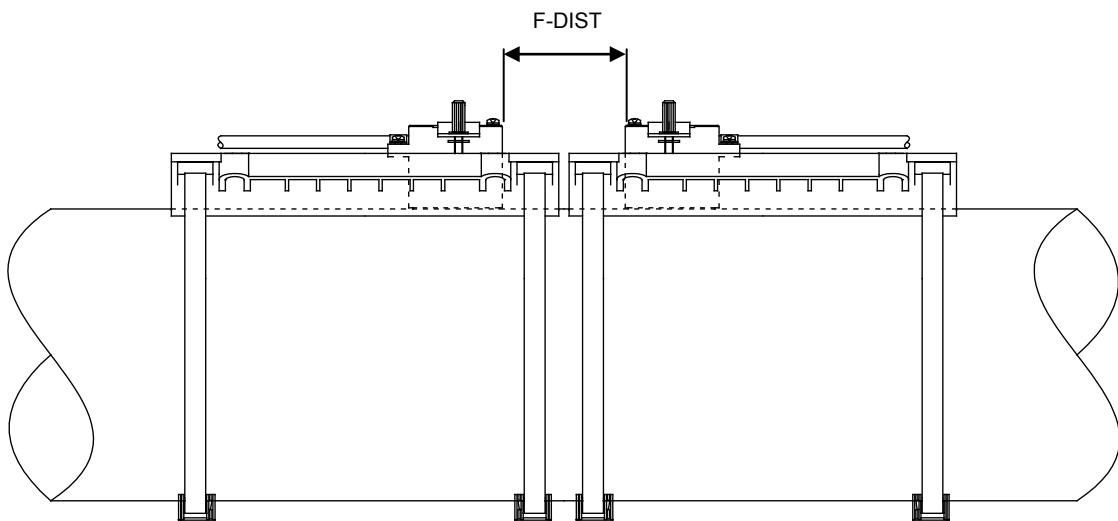

Fig. 1-2-9-13 Mounting method for a transducer mounting interval (F-DIST) of 50 mm or more

CAUTION

- The cut ends of stainless steel bands are sharp. Be sure to wear gloves and protective eyeglasses or goggles and perform the work carefully to avoid any injuries. Cover the cut ends of stainless steel bands with tapes etc..

- 1) Cut the supplied stainless steel bands to a length of the circumference of the pipe to be measured + approximately 200 mm, and fold back approximately 50 mm at one end.

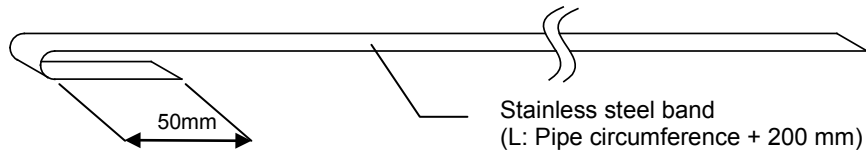

Fig. 1-2-9-14 Stainless steel band preparation

- 2) Set a fastening fixture onto the stainless steel band. (The slit in the winding shaft is positioned to facilitate this task when shipped from the factory.)

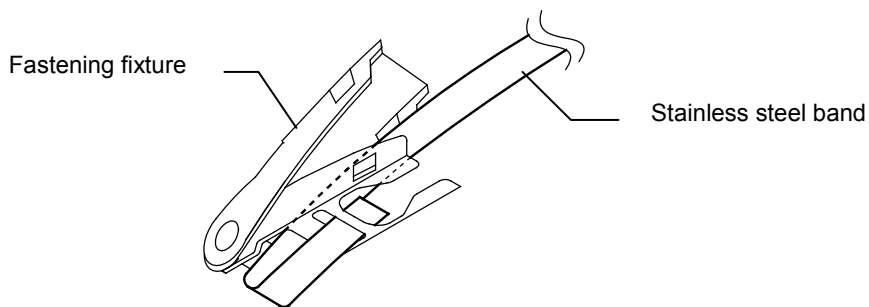

Fig. 1-2-9-15 Fastening fixture preparation

- 3) Pass the stainless steel band through the horizontal holes in the transducer holder, and wrap the band around the pipe.

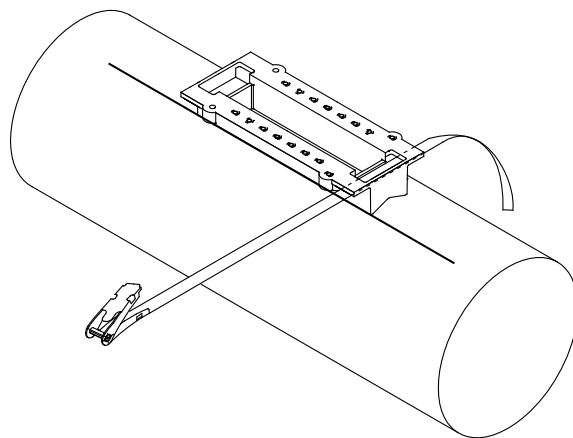

Fig. 1-2-9-16 Fixing the transducer holder (1)

- 4) Insert the tip of the stainless steel band into the slit in the winding shaft of the fastening fixture, pull the band tight, and then pull the lever down to the outside as shown by the arrow in the figure. (The stainless steel band is temporarily secured in this state.)

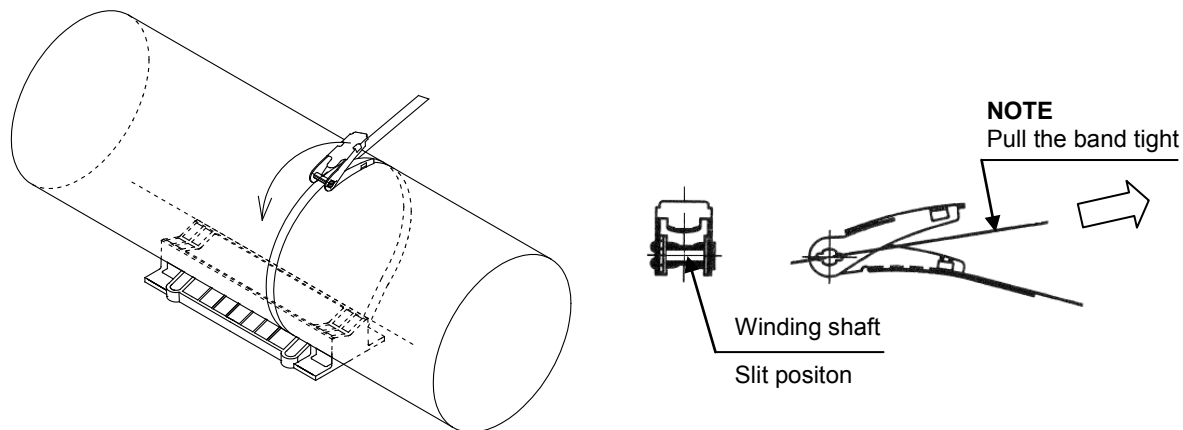

Fig. 1-2-9-17 Fixing the transducer holder (2)

- 5) Cut the stainless steel band so that approximately 30 to 40 mm remains extending from the fastening fixture.

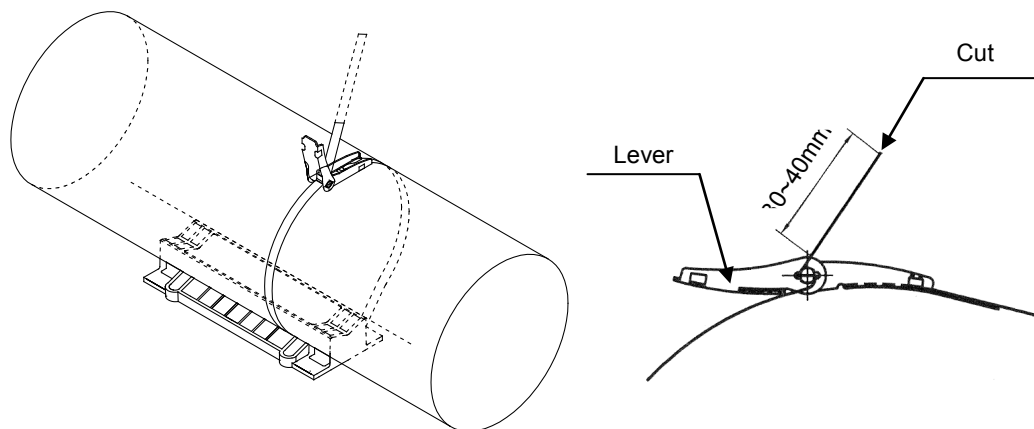

Fig. 1-2-9-18 Fixing the transducer holder (3)

- 6) Perform the same procedure and attach a stainless steel band on the opposite side of the transducer holder. Align the transducer holder with the marking line, and then move the levers to wind up the stainless steel bands by ratchet operation. The stainless steel bands should be sufficiently tight after one or two back-and-forth operations. After tightening the stainless steel bands, check the holder position again, and adjust if it has deviated from the marking line.

CAUTION

- Tighten the fastening fixtures by hand. Attempting to excessively wind up the stainless steel bands may cause the bands to break or damage the fastening fixtures.

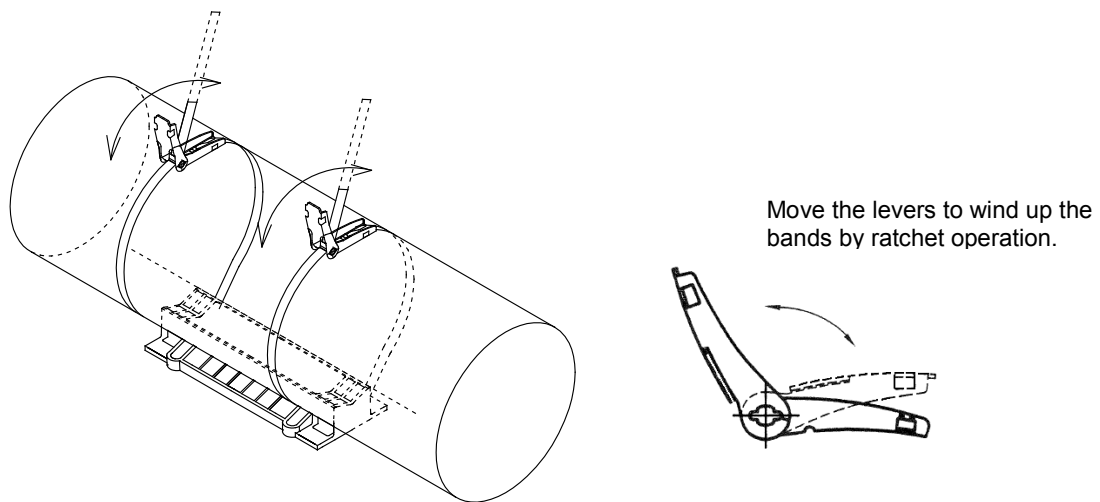

Fig. 1-2-9-19 Fixing the transducer holder (4)

- 7) When the stainless steel bands are sufficiently tightened, push the levers back over the bases. Make sure the openings on both sides of the levers fit completely over the protrusions on both sides of the bases.

CAUTION

- Be aware of potential injury from the stainless steel strap sharp ends.

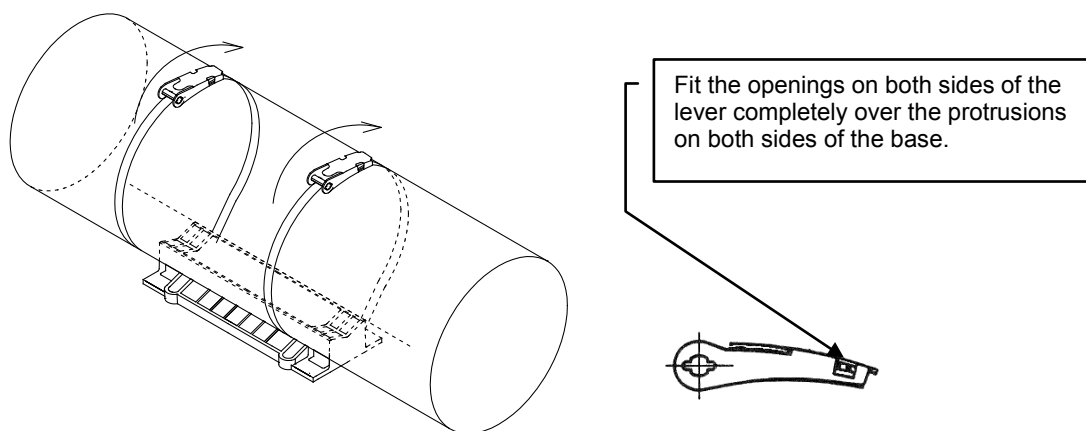

Fig. 1-2-9-20 Fixing the transducer holder (5)

(5) Mount the transducers

⚠ CAUTION
• Perform the work carefully, and do not touch the adhesive with bare hands, as this may result in a rash or inflammation.
NOTE
• Mount the transducers so that the cables are facing outwards. Measurement is not possible if the transducers are mounted facing the wrong direction.

- 1) Using a rag or other cloth moistened with alcohol, clean the acoustic surfaces of the transducers and the adhesive surfaces on the pipe side.
- 2) Squeeze out equal amounts of the epoxy adhesive resin and hardener onto a clean sheet, and mix together thoroughly using the supplied spatula.
- 3) Apply adhesive on the acoustic surfaces of the transducers to a thickness of about 1 to 2 mm.

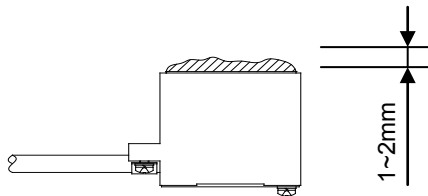

Fig. 1-2-9-21 Application of adhesive

NOTE
• When temporarily installing the transducers to investigate the feasibility of measurement, use the supplied couplant instead of adhesive.

- 4) Align each transducer with the marking line, press it against the pipe, and fix it with the clamp. Tighten a screw of the clamp equally so that the transducer does not incline. At this time, select the nuts on the holder side so that the clamp is positioned near the center of the holder in the longitudinal direction. Perform the adhesive work within 20 minutes after mixing the adhesive. The adhesive gels and hardens in approximately 40 minutes.

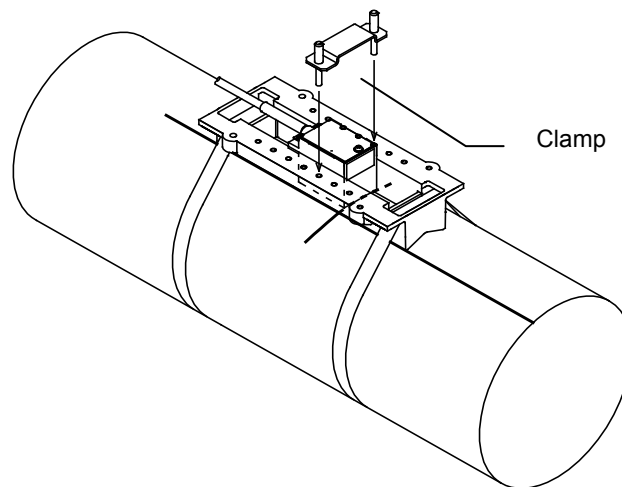

Fig. 1-2-9-22 Fixing the transducers

- 5) After mounting the transducers, check the transducer mounting interval (F-DIST) again.

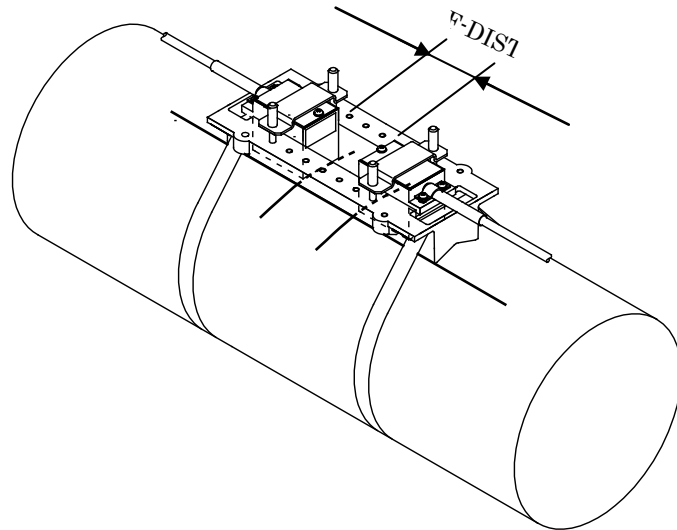

Fig. 1-2-9-23 Checking the transducer mounting interval (1)

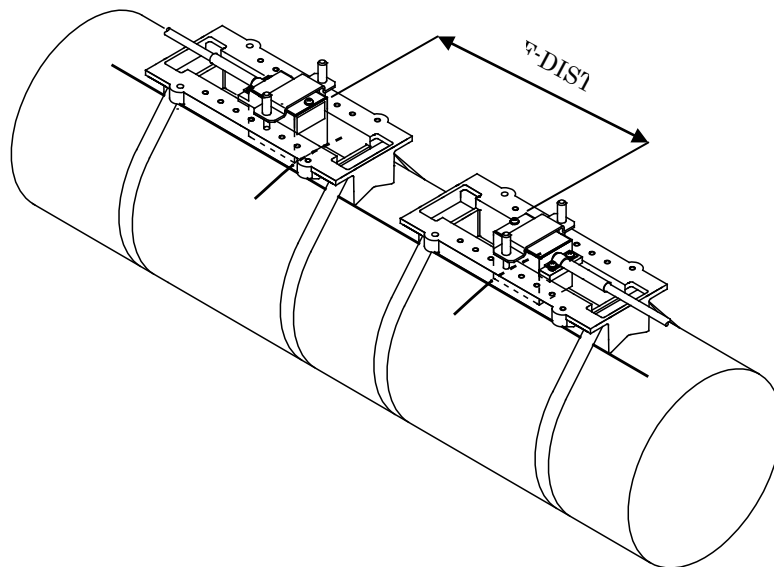

Fig. 1-2-9-24 Checking the transducer mounting interval (2)

1-2-10 Transducer installation (mounting by the Z method)

The procedure for mounting the transducers using the Z method (direct transmission method) is described below. Be sure to confirm the transducer mounting interval (F-DIST) before performing this work. Please refer to Chapter 1-2-12 (10) for the F-DIST confirmation method.

(1) Clean the pipe to be measured

Clean the pipe to facilitate gauge paper attachment and marking on the pipe.

(2) Using gauge paper, mark a horizontal line on the pipe.

Prepare the gauge paper. For details on the gauge paper, please refer to Chapter 1-2-11.

- 1) Wrap gauge paper closely around the pipe, and make sure the overlapping paper is squared on both edges ("A").
- 2) Mark the gauge paper by drawing a line between points "B" on both sides of the paper where the overlap ends.

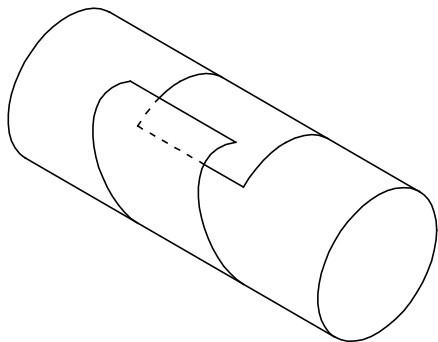

Fig. 1-2-10-1 Gauge paper (1)

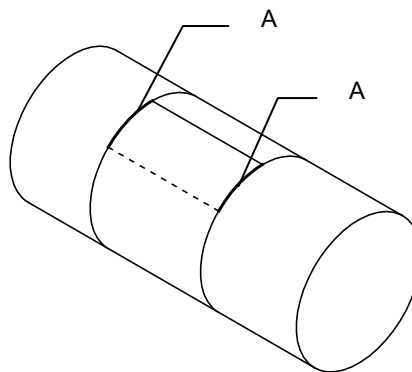

Fig. 1-2-10-2 Gauge paper (2)

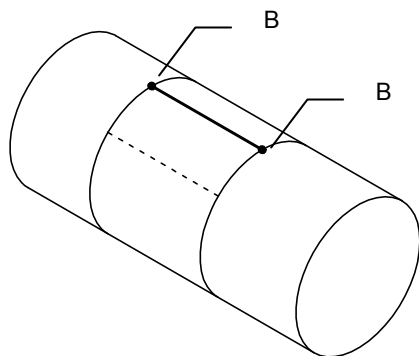

Fig. 1-2-10-3 Gauge paper (3)

- Remove the gauge paper from the pipe, align the mark "B" with the square edge of the paper, and fold the paper in half, making a crease. (Divide the pipe circumference in half.)

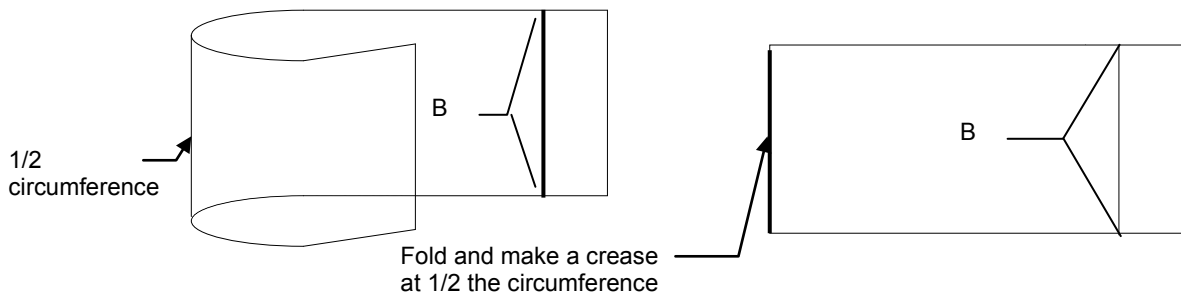

Fig. 1-2-10-4 Gauge paper (4)

- Wrap the creased gauge paper around the pipe again. Make sure the overlapping paper is squared on both edges ("A"), and then fix the paper using vinyl tape or other adhesive tape.
- Rotate the gauge paper around the pipe and move the crease to the transducer installation position.

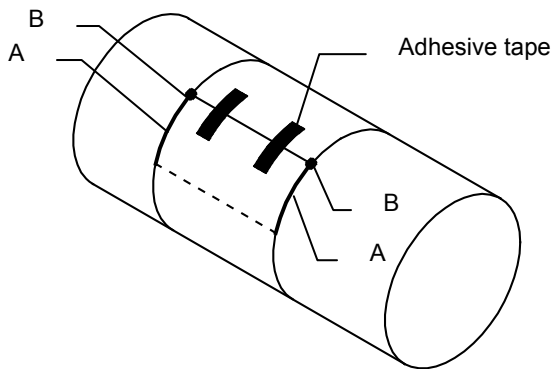

Fig. 1-2-10-5 Gauge paper (5)

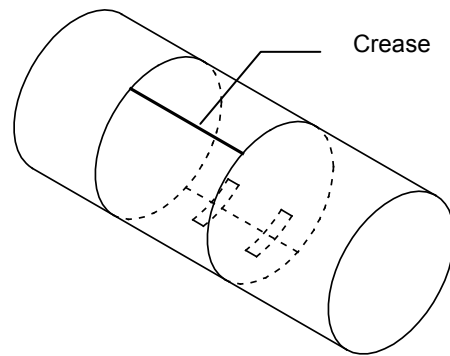

Fig. 1-2-10-6 Gauge paper (6)

- Using a pencil or marking pen, extend the crease lines outward from each edge of the gauge paper onto the pipe.
- Determine one edge of the gauge paper as the reference, and mark a reference point (C) on the pipe.
- Mark a line and a reference point (D) in the same manner on the opposite side of the pipe.

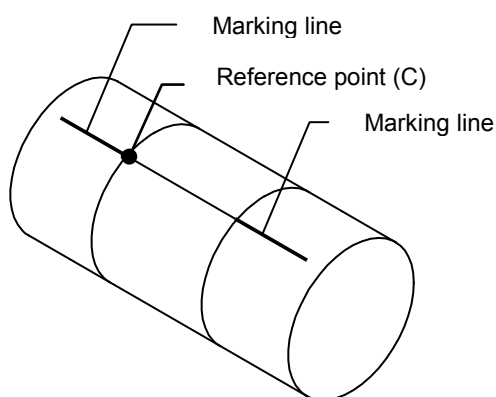

Fig. 1-2-10-7 Reference point mark (1)

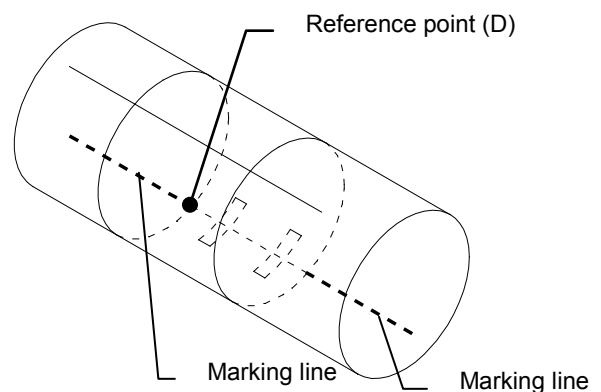

Fig.1-2-10-8 Reference point mark(2)

- 9) Remove the gauge paper and fill in the lines between the two sets of marking lines.
- 10) Mark the transducer mounting interval (F-DIST) on the pipe.

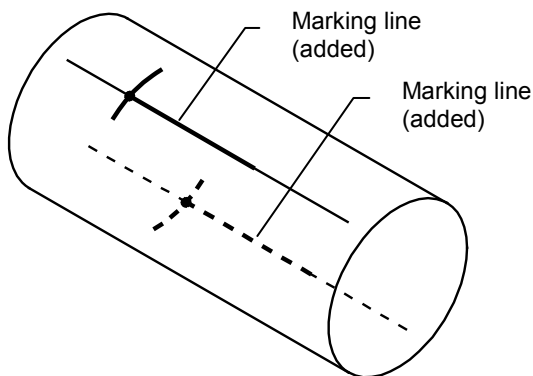

Fig. 1-2-10-9 Marking line (added)

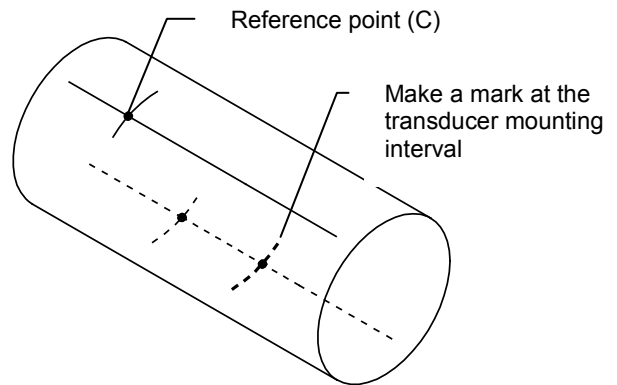

Fig. 1-2-10-10 Transducer mounting interval marks

(3) Polish the transducer installation positions.

- 1) Temporarily place a transducer holder at the reference point, and mark a range slightly larger than the transducer size.
 - 2) After marking the range, use sandpaper to polish the transducer mounting area as necessary to remove any bumps or unevenness.
 - 3) Perform the same procedure and polish the mounting surface for the other transducer as well.
- *) If polishing is insufficient and the surface remains uneven, the transmittance of the ultrasonic waves from the transducer will become weak.

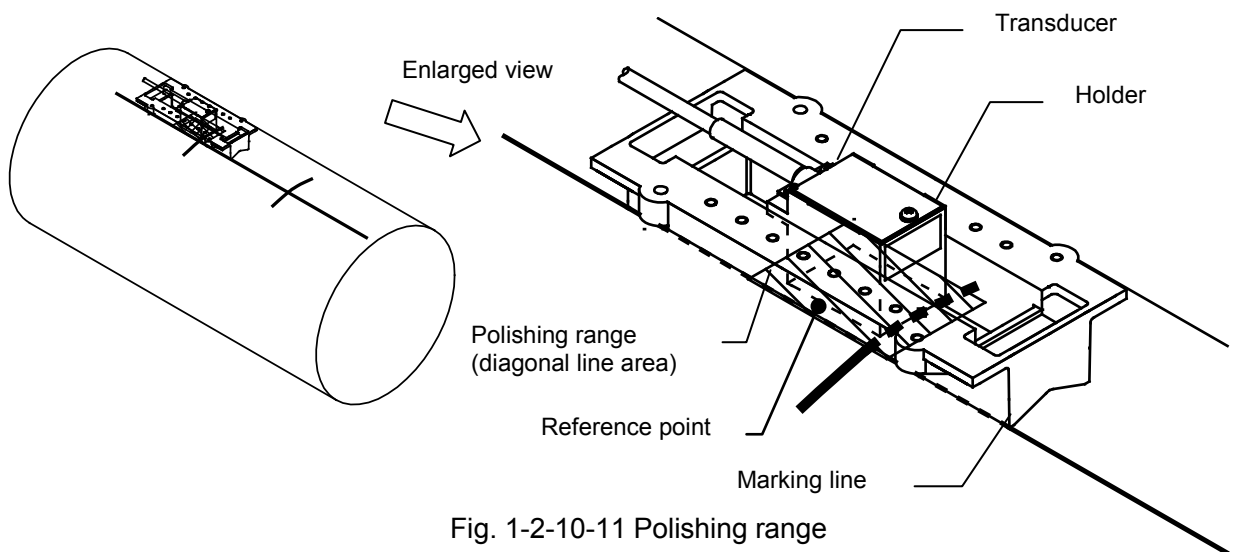

Fig. 1-2-10-11 Polishing range

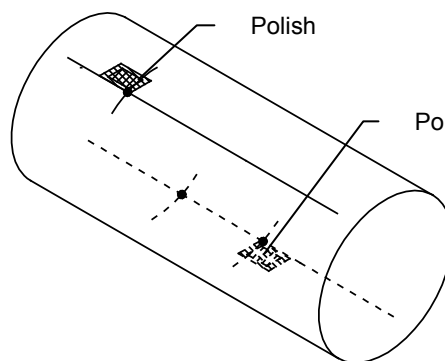

Fig. 1-2-10-12 Polishing the mounting positions

(4) Install the transducer holders

There are three different transducer holder mounting methods as follows according to the pipe bore and the transducer mounting interval (F-DIST).

- A: When the pipe size is DN50mm or less
- B: When the pipe size is DN65mm or more and the mounting interval is less than 50 mm
- C: When the pipe size is DN65mm or more and the mounting interval is 50 mm or more

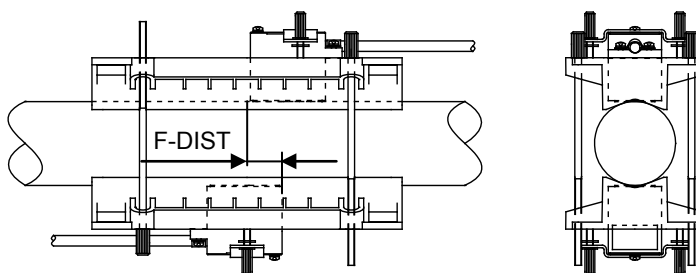

Fig. 1-2-10-13 A: Mounting method for a pipe size of DN50mm or less

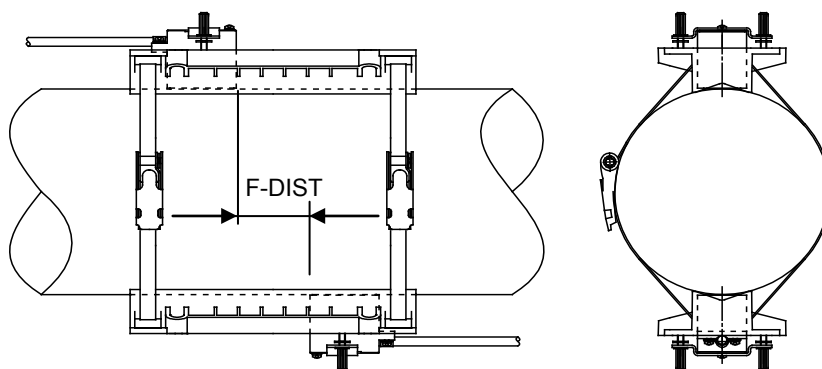

Fig. 1-2-10-14 B: Mounting method for a pipe size of DN65mm or more and a mounting interval of less than 50 mm

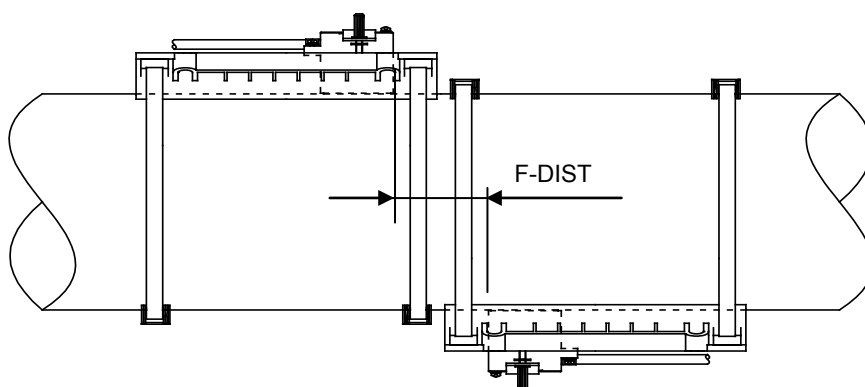

Fig. 1-2-10-15 C: Mounting method for a pipe size of DN65mm or more and a mounting interval of 50 mm or more

[A: When the pipe size is 2" or less]

Mount the holders using the supplied thumb screws.

- 1) Clasp the pipe to be measured between two holders on opposite sides. Pass the supplied thumb screws through the through holes, and tighten the screws. (Be careful to mount the transducers facing the proper direction.)

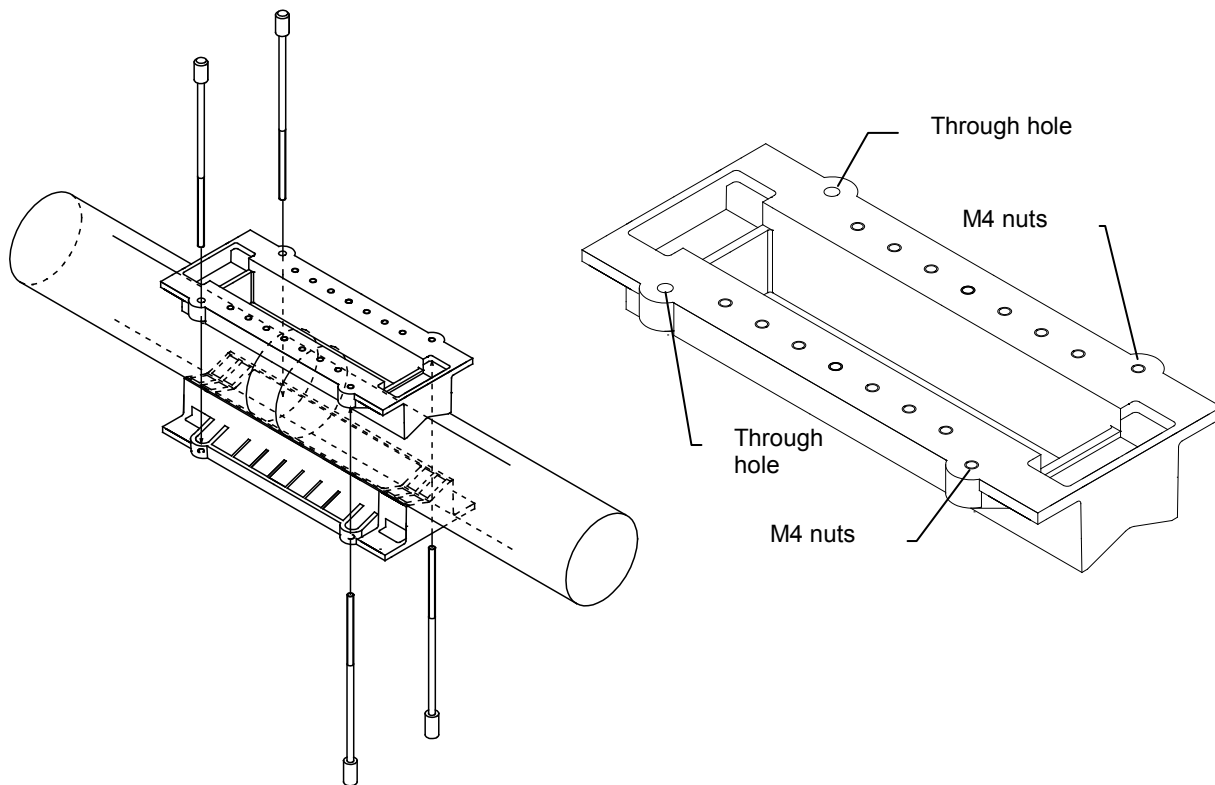

Fig. 1-2-10-16 DN50mm or less, Z mounting method (1)

- 2) Adjust the holders so that they are parallel to each other and tighten the thumb screws. Check the parallelism of the holders by the distance between the collars of the opposing holders.

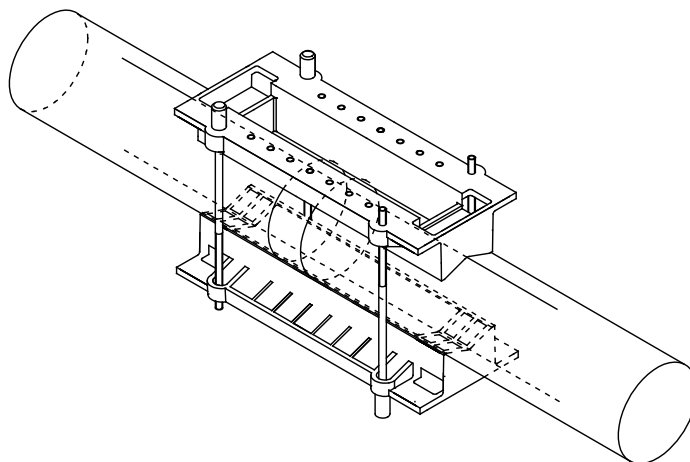



Fig. 1-2-10-17 DN50mm or less, Z mounting method (2)

[B: When the pipe size is 2 1/2" or more and the mounting interval is less than 2"]

	<p>CAUTION</p> <ul style="list-style-type: none"> The cut ends of stainless steel bands are sharp. Be sure to wear gloves and protective eyeglasses or goggles and perform the work carefully to avoid any injuries. Cover the cut ends of stainless steel bands with tapes etc..
---	---

Mount the holders together using stainless steel bands.

- 1) Cut the supplied stainless steel bands to a length of the circumference of the pipe to be measured + approximately 200 mm, and fold back approximately 50 mm at one end.

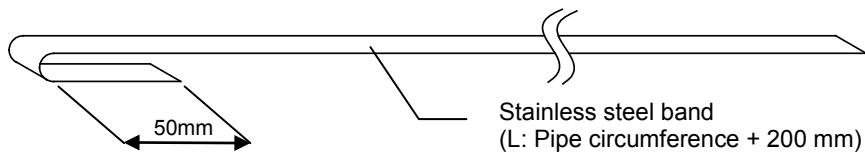

Fig. 1-2-10-18 Stainless steel band preparation

- 2) Set a fastening fixture onto the stainless steel band. (The slit in the winding shaft is positioned to facilitate this task when shipped from the factory.)

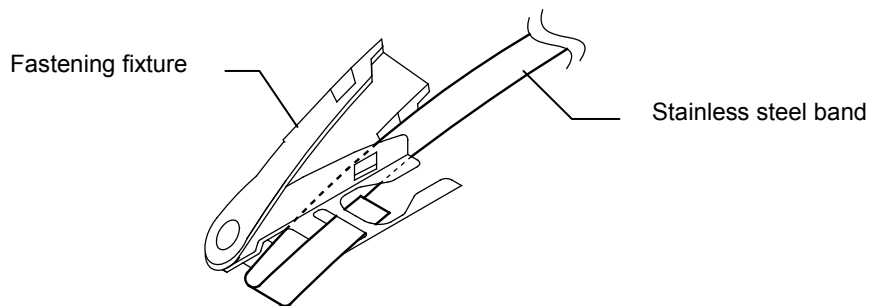

Fig. 1-2-10-19 Fastening fixture preparation

- 3) Pass the stainless steel band through the horizontal holes of the two transducer holders, and wrap the band around the pipe.

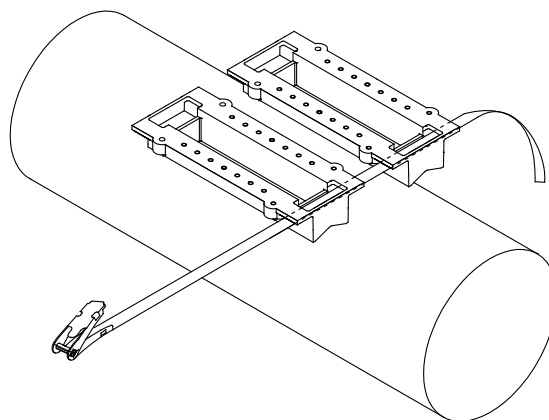

Fig. 1-2-10-20 Fixing the transducer holders (1)

- 4) Insert the tip of the stainless steel band into the slit in the winding shaft of the fastening fixture, roughly adjust the holder positions(*1), pull the band tight, and then pull the lever down to the outside as shown by the arrow in the figure. (The stainless steel band is temporarily secured in this state.)

*1) Temporarily fixing each holder in place using vinyl tape or other adhesive makes this task easier.

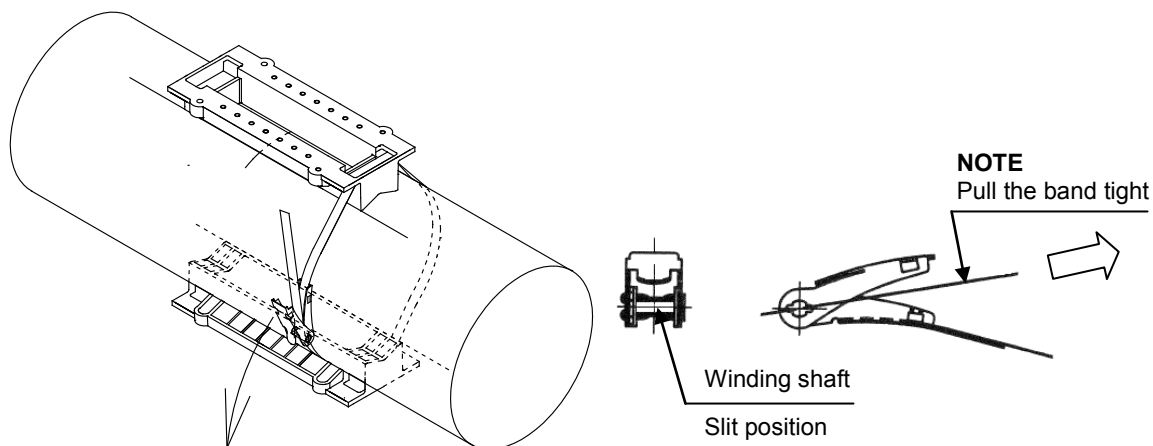

Fig. 1-2-10-21 Fixing the transducer holder (2)

- 5) Cut the stainless steel band so that approximately 30 to 40 mm remains extending from the fastening fixture.

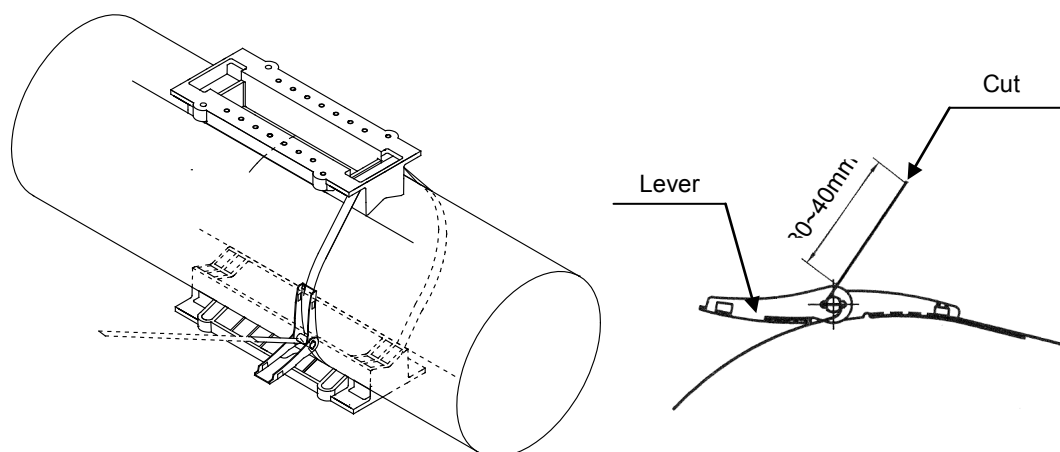



Fig. 1-2-10-22 Fixing the transducer holder (3)

- 6) Perform the same procedure and attach a stainless steel band on the opposite side of the transducer holders. Align the transducer holders with the marking lines, and then move the levers to wind up the bands by ratchet operation. The stainless steel bands should be sufficiently tight after one or two back-and-forth operations. After tightening the stainless steel bands, check the holder positions again, and adjust if they have deviated from the marking lines.

	CAUTION
<ul style="list-style-type: none"> • Tighten the fastening fixtures by hand. Attempting to excessively wind up the stainless steel bands may cause the bands to break or damage the fastening fixtures. 	

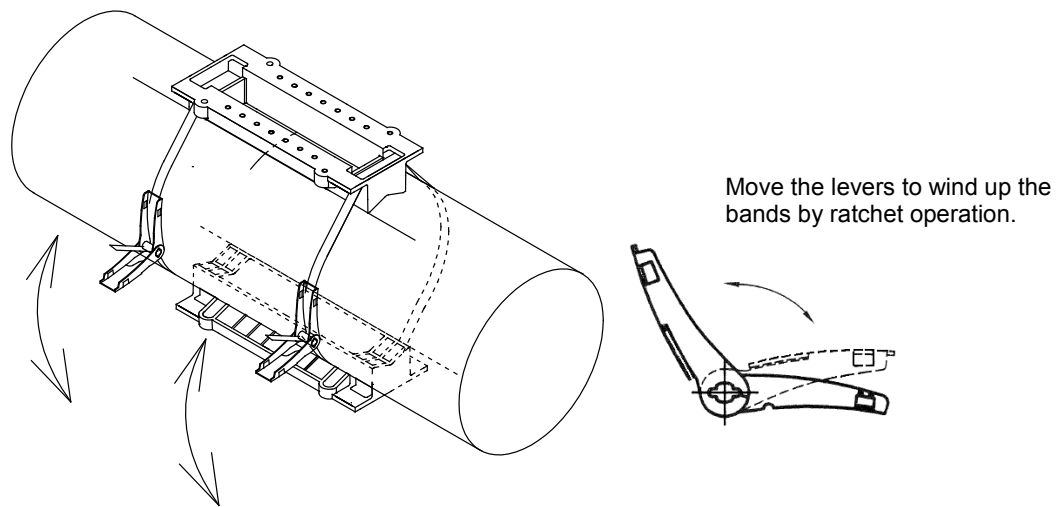



Fig. 1-2-10-23 Fixing the transducer holder (4)

- 7) When the stainless steel bands are sufficiently tightened, push the levers back over the bases. Make sure the openings on both sides of the levers fit completely over the protrusions on both sides of the bases.

	CAUTION
<ul style="list-style-type: none"> • Be careful of the cut ends of the stainless steel bands as injuries may occur. 	

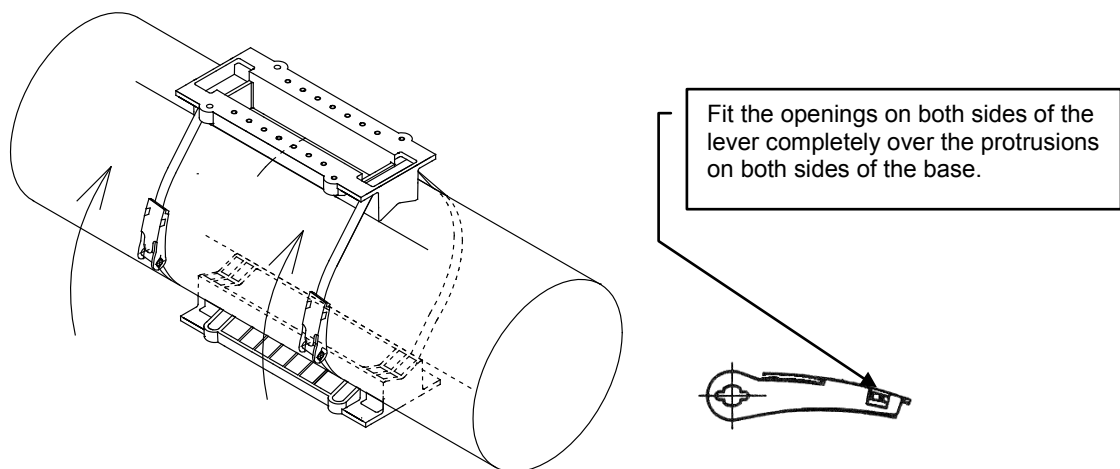

Fig. 1-2-10-24 Fixing the transducer holder (5)

[C: When the pipe size is 2 ½” or more and the mounting interval is 2” or more]

Mount each holder separately using stainless steel bands. For the holder fixing method, please refer to “(4) Install the transducer holders” in Chapter 1-2-9 “Transducer installation (mounting by the V method)”.

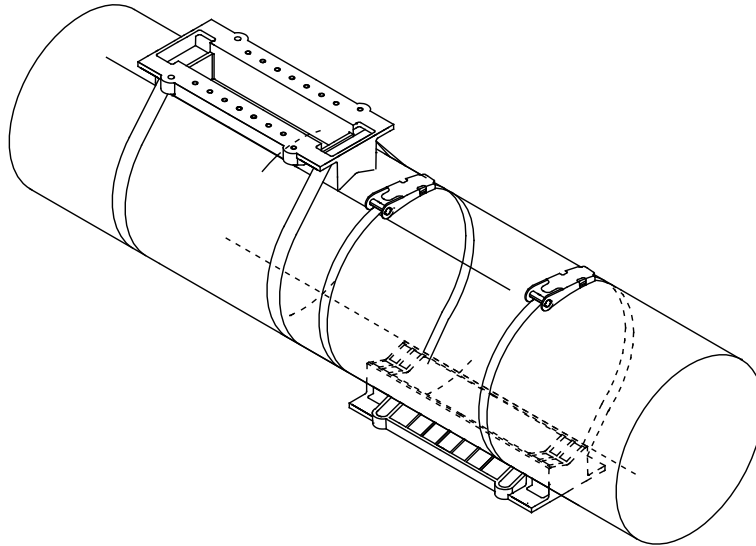

Fig. 1-2-10-25 Fixing the transducer holders

(5) Mount the transducers

CAUTION
<ul style="list-style-type: none"> • Perform the work carefully, and do not touch the adhesive with bare hands, as this may result in a rash or inflammation.
NOTE
<ul style="list-style-type: none"> • Mount the transducers so that the cables are facing outwards. Measurement is not possible if the transducers are mounted facing the wrong direction.

- 1) Using a rag or other cloth moistened with alcohol, clean the acoustic surfaces of the transducers and the adhesive surfaces on the pipe side.
- 2) Squeeze out equal amounts of the epoxy adhesive resin and hardener onto a clean sheet, and mix together thoroughly using the supplied spatula.
- 3) Apply adhesive on the acoustic surfaces of the transducers to a thickness of about 1 to 2 mm.

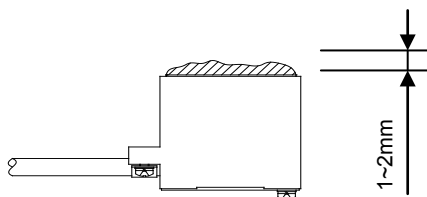

Fig. 1-2-10-21 Application of adhesive

NOTE
<ul style="list-style-type: none"> • When temporarily installing the transducers to investigate the feasibility of measurement, use the supplied couplant instead of adhesive.

- 4) Align each transducer with the marking line, press it against the pipe, and fix it with the clamp. Tighten a screw of the clamp equally so that the transducer does not incline. At this time, select the nuts on the holder side so that the clamp is positioned near the center of the holder in the longitudinal direction. Perform the adhesive work within 20 minutes after mixing the adhesive. The adhesive gels and hardens in approximately 40 minutes.

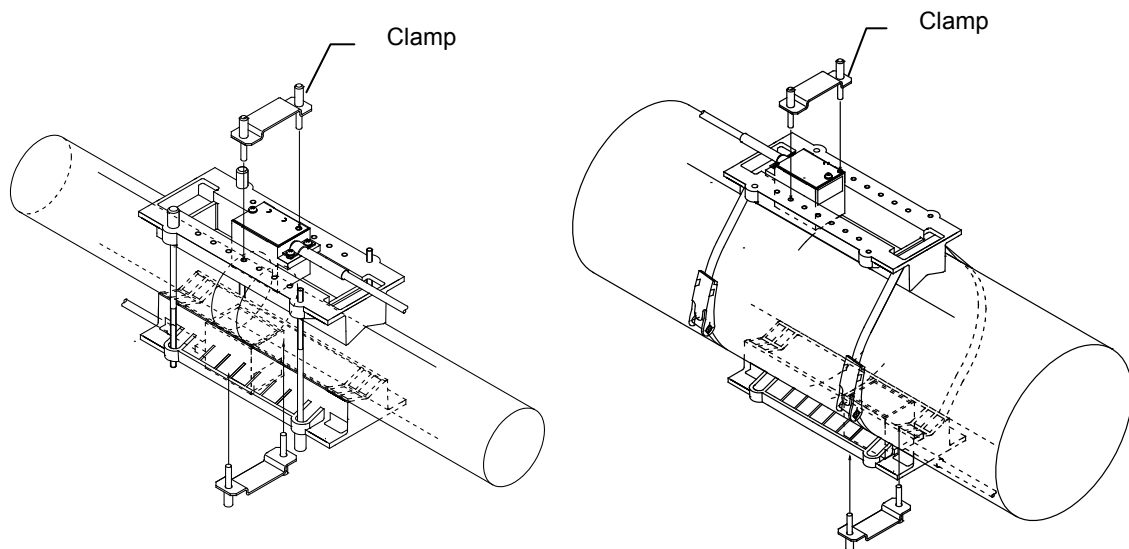

Fig. 1-2-10-22 Fixing the transducers

- 5) After mounting the transducers, check the transducer mounting interval (F-DIST) again.

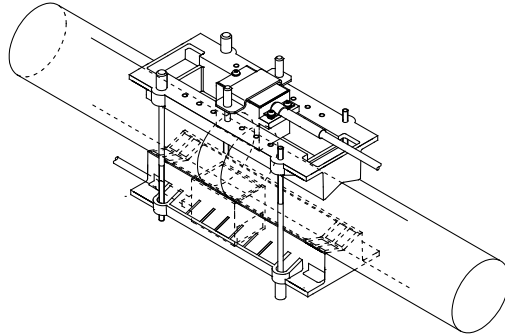

Fig. 1-2-10-23 Checking the transducer mounting interval – A

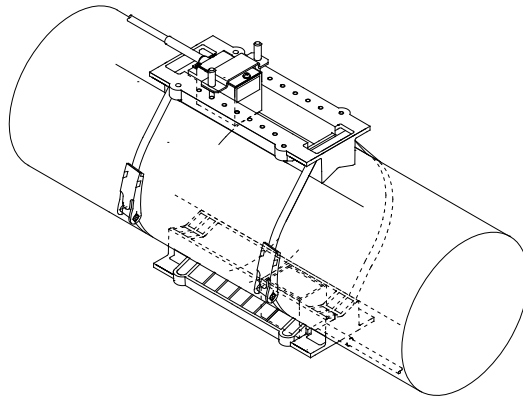

Fig. 1-2-10-24 Checking the transducer mounting interval – B

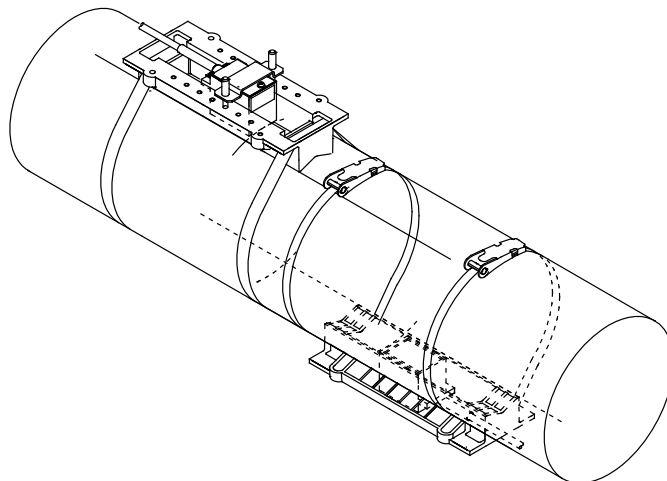

Fig. 1-2-10-25 Checking the transducer mounting interval - C

1-2-11 Gauge paper

Gauge paper is used to mark a horizontal line on the pipe to be measured. Prepare a rectangular sheet of gauge paper that is longer (approximately 4D to 5D) than the circumference of the pipe to be measured. The width should be as shown in Table 1-2-11 according to the pipe bore. A thin and tough plastic sheet is recommended as the gauge paper material.

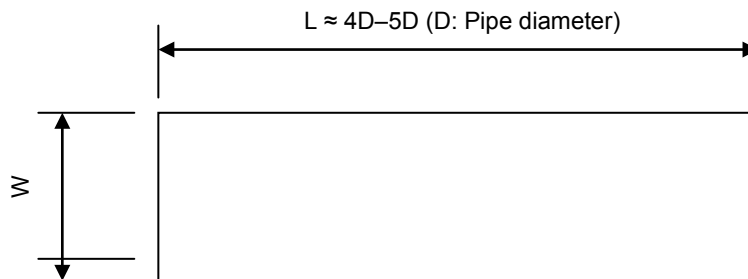

Fig. 1-2-11 Gauge paper dimensions

Pipe bore (approximate)	L	W (mm)
2" – 12"	approx. 4D-5D (D: Pipe diameter)	4"
14" – 18"		8"
20" – 24"		12"

Table 1-2-11 Approximate gauge paper width

1-2-12 Input parameters by Commissioning Software

Commissioning software is used to configure for the flowmeter by a personal computer. 4 keys operation with LCD is available. Please refer to chapter 2.

- (1) System requirements
OS: Windows 7, Vista, Xp
Port: USB 1.0 or higher

**CAUTION**

Connection USB cable would be better to attach ferrite core to avoid noise.

- (2) Software installation
a) Copy all files contained in CD-ROM to any folder in PC.
b) Execute usbdriver/CDM20802_setup.exe to install Virtual Comm Port driver.

- (3) Connection to main unit

**CAUTION**

Connection USB cable length must be less than 3m long in case of complying with EC directive.

Open cover of USB port on main unit and connect USB cable. When the USB cable connects to main unit, then USB driver will install automatically.

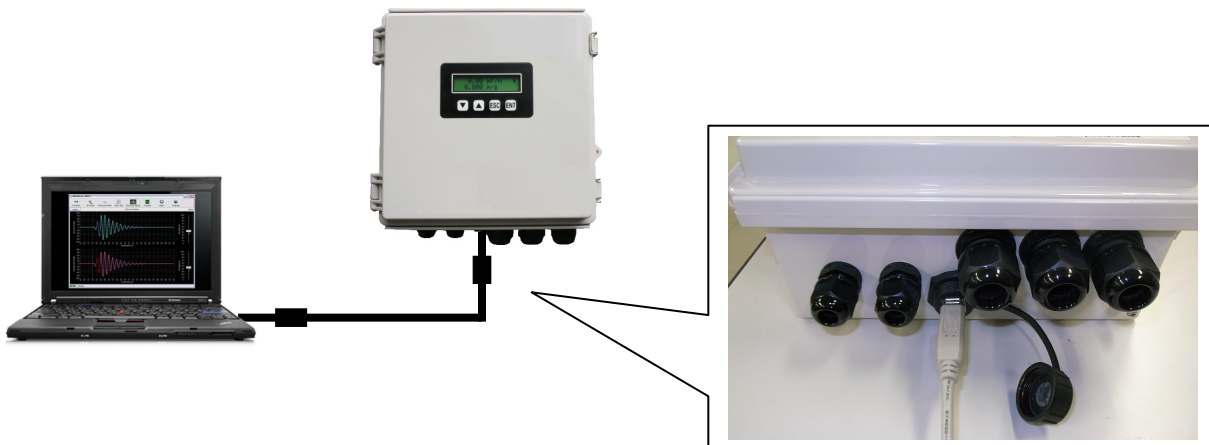
**NOTE**

Do not connect several flowmeters to a PC at the same time.

- (4) Start up software
Double click the commissioning software "LF810Config.exe". Software version will be indicated at title bar.

(5) Communication port setting

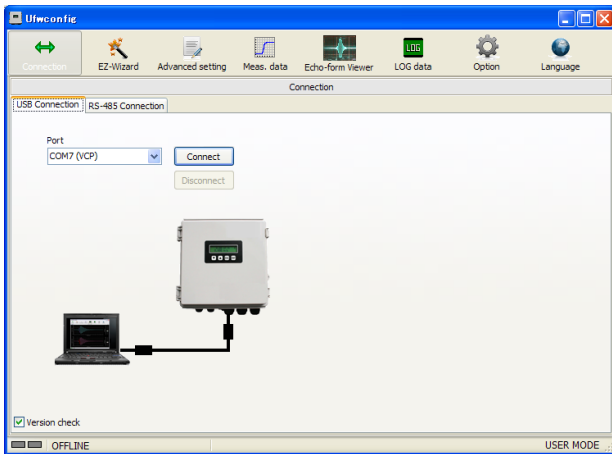

After connection of main unit and PC, VCP port can be selected. Select the port, then click "Connect" button.

(6) Check version

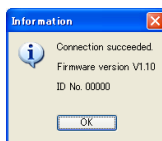

When the communication succeeded between main unit and PC, firmware version and ID No. will be shown.

(7) EZ-wizard for basic configuration

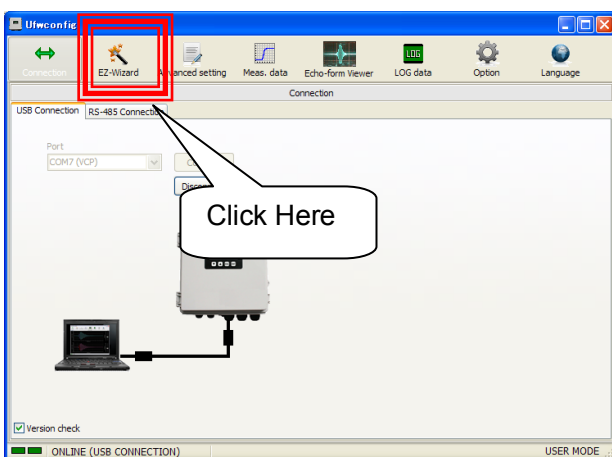

When click "EZ-Wizard", the wizard menu will open.

(8) System setting

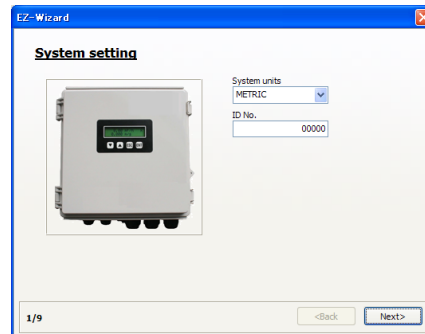

Select "System unit" from Metric and English. Then press "Next". ID No. can be set, if required.

Metric	English	Conversion reference
mm	in	1[mm] = 0.0393701[in] 1[in] = 25.4[mm]
m	ft	1[m] = 3.28084[ft] 1[ft] = 0.3048[m]
m/s	ft/s	1[m/s] = 3.28084[ft/s] 1[ft/s] = 0.3048[m/s]

English	Conversion reference
ft ³	1[m ³] = 35.3147[ft ³] 1[ft ³] = 0.0283168[m ³]
gal (U.S. fluid gallon)	1[m ³] = 264.172[gal] 1[gal] = 3.785411784[L]
bbbl (Standard barrel for liquids)	1[m ³] = 8.38641[bbbl] 1[bbbl] = 119.240471196[L]
acf	1[m ³] = 8.107132e-4[acf] 1[acf] = 1233.48184[m ³]

(9) Pipe, Sensor and Fluid type

Input and select all data.

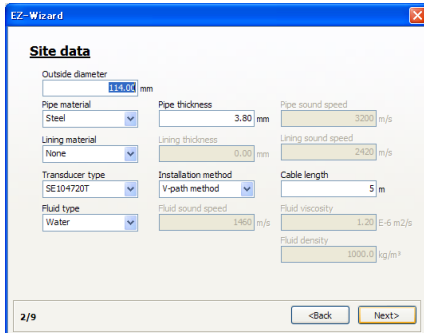

For "Pipe", "Lining" and "Fluid", their sound velocity values are automatically defined when you select the listed material or fluid. They are nominal values. If you would like to select another material which is listed, please select "USER-defined". Then actual velocity of the material will be required to enter. Otherwise you can select public value from reference list. Besides pipe material, actual fluid velocity will also be required to enter. In case of "water", you need to input only temperature of water. Otherwise you can select public value from reference list.

After selecting and entering values, press "Next".

If F-DIST will be calculated as Negative value, error message will be shown. In that case, please select Z-path method instead.

(10) Confirm mount distance

Calculated distance between transducers will be shown as below.

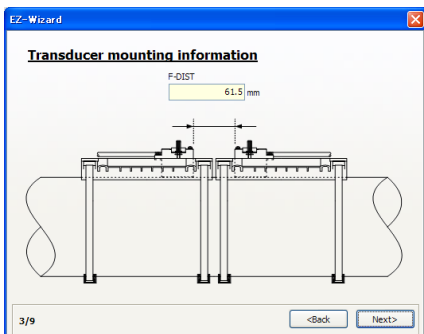

These values should be memorized for proper sensor installation (see Chapter 1-2-9),

"Transducer Installation Procedure".

(11) Unit Setting

Exponents and flow rate unit will be selected in this section.

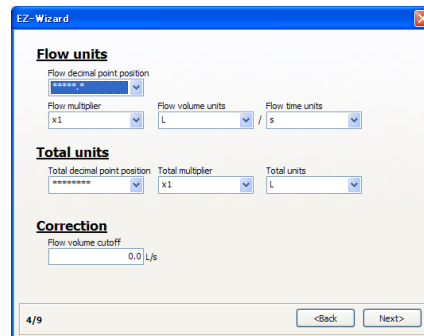

(12) Alarm setting

All alarm settings can be defined in this section. You may set at "Advanced menu" later.

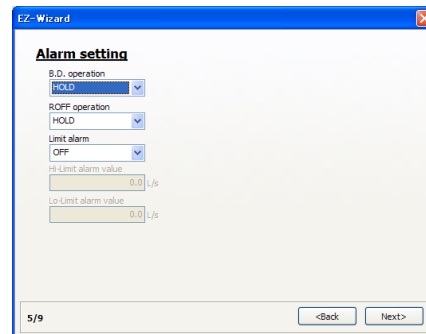

ROFF	No receiving echo warning
B.D.	Hardware breakdown warning
Limit Alarm	Alarm activates exceeding limited range

(13) LCD display setting

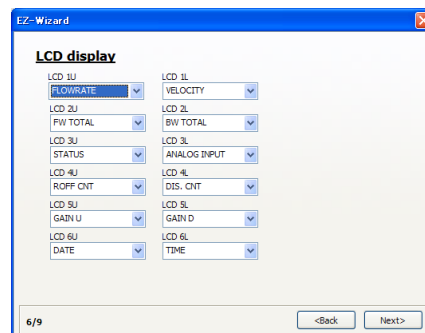

(14) IO setting1

Analog output

Contact output

Analog range - You can set item for contact output and its characteristics in this section.

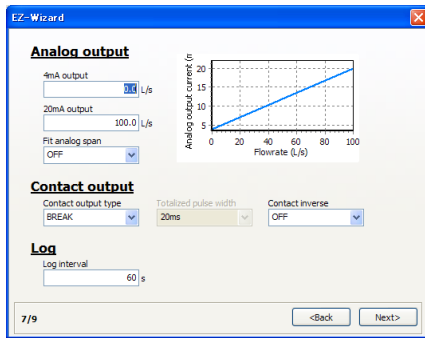

(15) I/O setting2

Digital communication (*Option)

Analog input (*Option)

If optional Board is attached, please set this parameter.

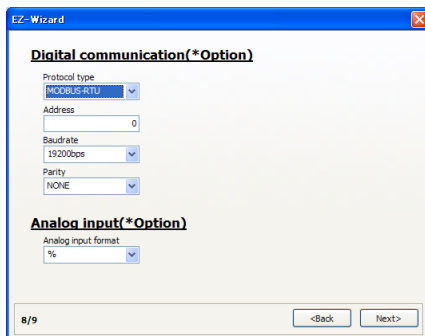

(16) Online-Upload

As a final step, you can upload all set parameter into on-lined-main unit.

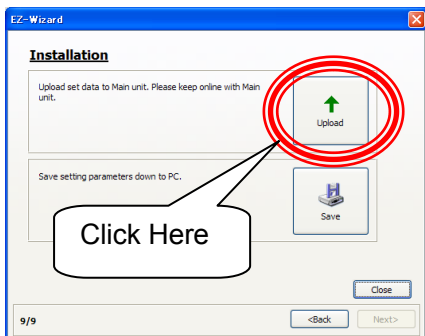

Then please click "Finish" to exit wizard then skip to (17).

Offline installation

If you would like to upload later on, you can also save all set parameter into your PC.

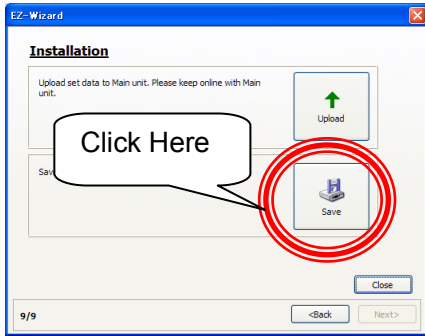

To upload file saved into your PC to flowmeter, click Advanced setting, select "Download/Upload" tab as below.

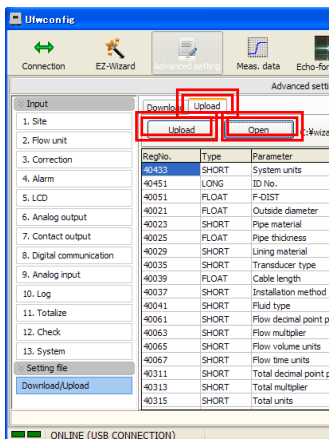
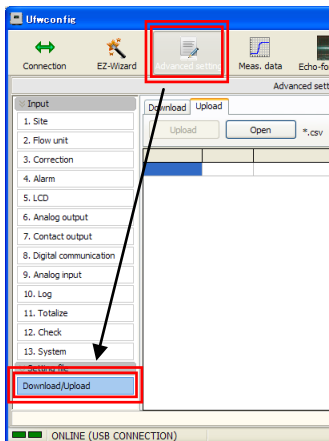

Select "Upload" tab and open the parameter file. Then click Upload button as below indicated.

Then please go to (17).

Flow Measurement

Transducer installation should be completed.
 Pipe should be full-filled with fluid.
 Flow should be stable enough.

(17) Final check (Status)
 Open "Meas. monitor".

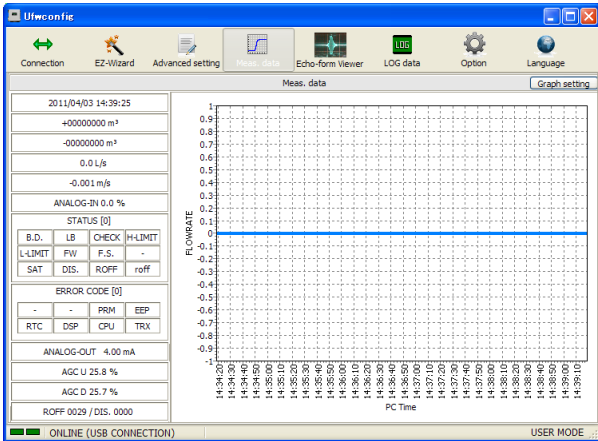

Item	Instruction
UF TIME	Internal Time
FWTOTAL	Forward totalizing value
BWTOTAL	Backward totalizing value
FLOWRATE	Measured flowrate
VELOCITY	Measured flow velocity
ANALOG-IN	Analog input value
SATUS	roff: Momentum No receiving echo warning ROFF: No receiving echo warning DIS.: Disturbance detected. SAT: Saturated echo detected F.S.: Full scale warning FW: Forward direction measurement H-LIMIT: Lower limit warning U-LIMIT: Upper limit warning CHECK: Check mode indication LB: Low battery alarm B.D.: Breakdown alarm
ERROR CODE	TRX: Transmit-Receiving circuit B.D. CPU: CPU B.D. DSP: DSP B.D. RTC: RTC B.D. EEP: Setting data memory B.D. PRM: Inputted data error
AGC U	Upside Gain Amplitude
AGC D	Downside Gain Amplitude
ROFF/DIS.	Detection history (Q'ty)

“ROFF”: No receiving echo Warning

An error will be indicated when any echo can not be detected on transducers.

- Mounting distance
- Mounting direction
- Cable connection
- Fluid condition
- Pipe condition
- Parameter settings
- and so on.

In this case, please check each cause and improve.

(18) Final check (Echo)
 Open "Echo-form" menu to confirm whether proper reflection comes back.

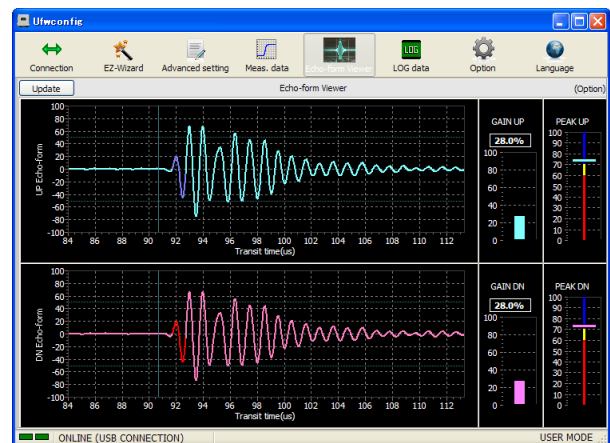

Peak	Classification
70 to 100	Appropriate echo and location
60 to 70	Relatively low echo. Relocate mounting position or change to Z-path method to get proper echo.
0 to 60	Very low echo. Relocate mounting position or change to Z-path method to get proper echo.

* This description is a typical reference. It may not be suitable for every actual application.

Commissioning is completed when the flowmeter starts to show flow rate measurements without any alarm indication.

Go to Chapter II "Operations" for setting output signals.

2. Operations

2-1 Key operation

This chapter describes the system operation method, screen and window navigation, and handling of the flowmeter.

WARNING

Do not open the front panel when the equipment is working. High voltage parts causing electrical shock are inside.

NOTE

Measurement operation continues during data setting and check operations. Measurement values during operation may change when settings are changed.

2-1-1 Basic operation

Fig. 2-1-1 shows the operation panel, and Table2-1-1 lists the key functions.



Fig. 2-1-1 Operation panel

Table2-2-1-1 Key functions

Key	Measurement screen	Menu mode
[▼]	Switches the display page.	Decrease the blinking digit.
[▲]	Switches the display page.	Increase the blinking digit.
[ESC]	Display page 1.	Cancel
[ENT]	Switches to Menu mode.	Enter

Fig. 2-1-2 shows the measurement screen and menu screen transition and key operations.

The page appearing in the LCD display can be switched by key operations. The measurement values displayed in each page can be changed by the settings.

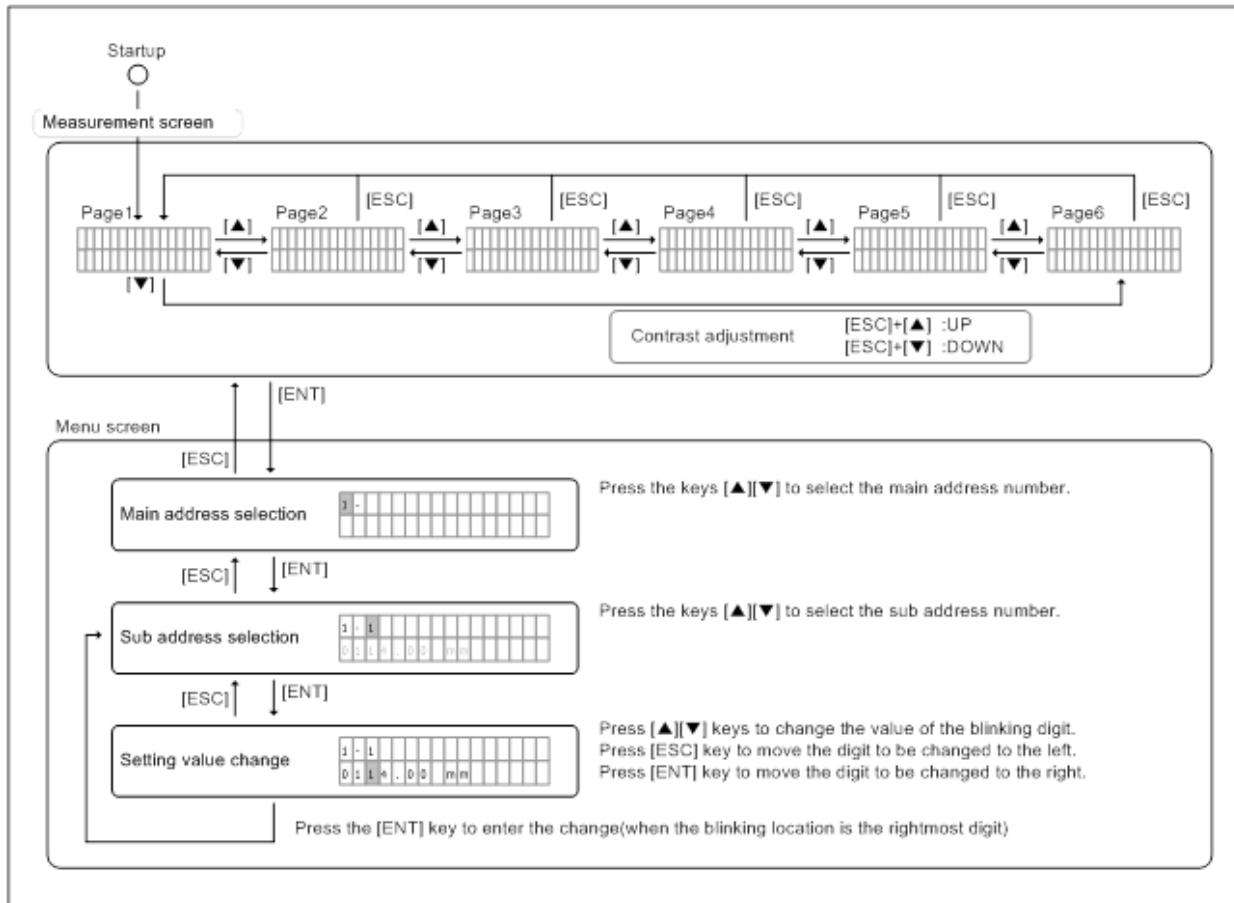

Cancel parameter protection to change setting by key operation.
Refer to Fig. 2-3-5 for measurement screens of Page1-Page6.

Fig. 2-1-2 LCD screen transitions

NOTE
When key operation is not performed for certain period of time, display goes out for 1 second every 2.5 minutes cycle time for refresh purpose.

2-1-2 Contrast adjustment

Hold down the [ESC] key at the measurement screen and press the [▲] key to increase the LCD contrast or the [▼] key to decrease the LCD contrast.

2-1-3 LCD messages

Display	Description
PROTECTION	When you try to change a parameter while the parameter protection function is set to "ON", "PROTECTION" is displayed and the parameter cannot be changed.
READ ONLY	When you try to change a read only parameter, "READ ONLY" is displayed and the parameter cannot be changed.
RANGE ERROR	When a setting value outside the input range is entered, "RANGE ERROR" is displayed and the parameter returns to the original value.
#####	For example, when the decimal point position is set to ***.*** and +QMAX is set to +10.000 , and the decimal point position is then changed to **.****, +10.000 cannot be displayed. In this case, +QMAX is displayed as ##.####.

2-1-4 Protection release

Just after turning on the power, protection mode is activated to avoid unexpected operation. Prior to changing any parameters, please unset protection mode.

Table2-1-4 Procedure of protection mode release

Operation	LCD	Description
Power on.	[0.0 L/s] [0.000 m/s]	Measurement screen
Push [ENT] key 1 time.	[1- SITE] [F-DIST 8.5 mm]	Entering menu screen
Push [▼] key 1 time or push [▲] key 12 Times	[13- SYSTEM] []	Select main menu "13- SYSTEM"
Push [ENT] key 1 time	[13-1 PROTECTION] [(1) ON]	Select sub menu "13-1 PROTECTION"
Push [ENT] key 1 time	[13-1 PROTECTION] [(1) ON]	Enter selecting mode.
Push [▼] key 1 time	[13-1 PROTECTION] [(0) OFF]	Change the parameter
Push [ENT] key 1 time	[13-1 PROTECTION] [(0) OFF]	Release protection mode

2-2 Commissioning software



CAUTION

Connection USB cable would be better to attach ferrite core to avoid noise,

2-2-1 Advanced setting

When "Advanced setting" is selected all related parameters will be shown as below.

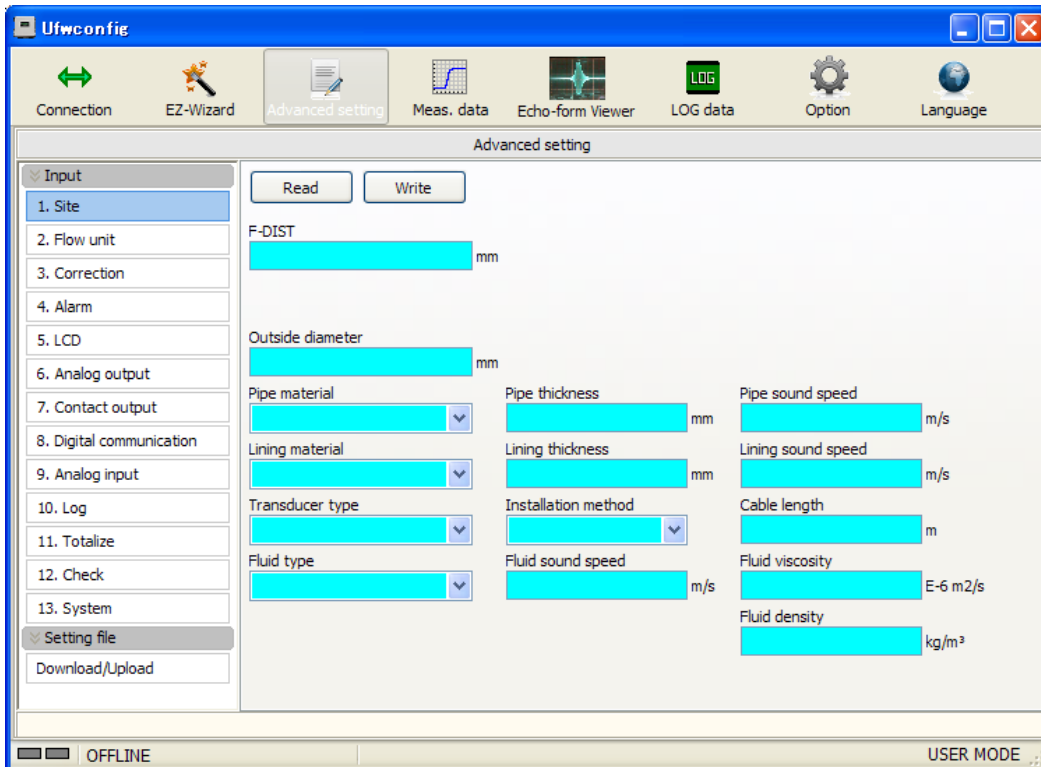

Button	Function
List	Parameter group by list
Read	Read out from main unit
Write	Upload to main unit

Item colors	Meanings
Aqua (Blue)	Status before read from the flowmeter
White	Current flowmeter setting
Green	Changed setting (Click the [Write] button to write the setting data to the flowmeter.)
Yellow	Setting value outside the setting range

2-2-2 Measuring data and status

When "Meas.data" is selected, Measuring data and status will be shown.

Left side: Measuring status

Right side: Measuring data trend graph

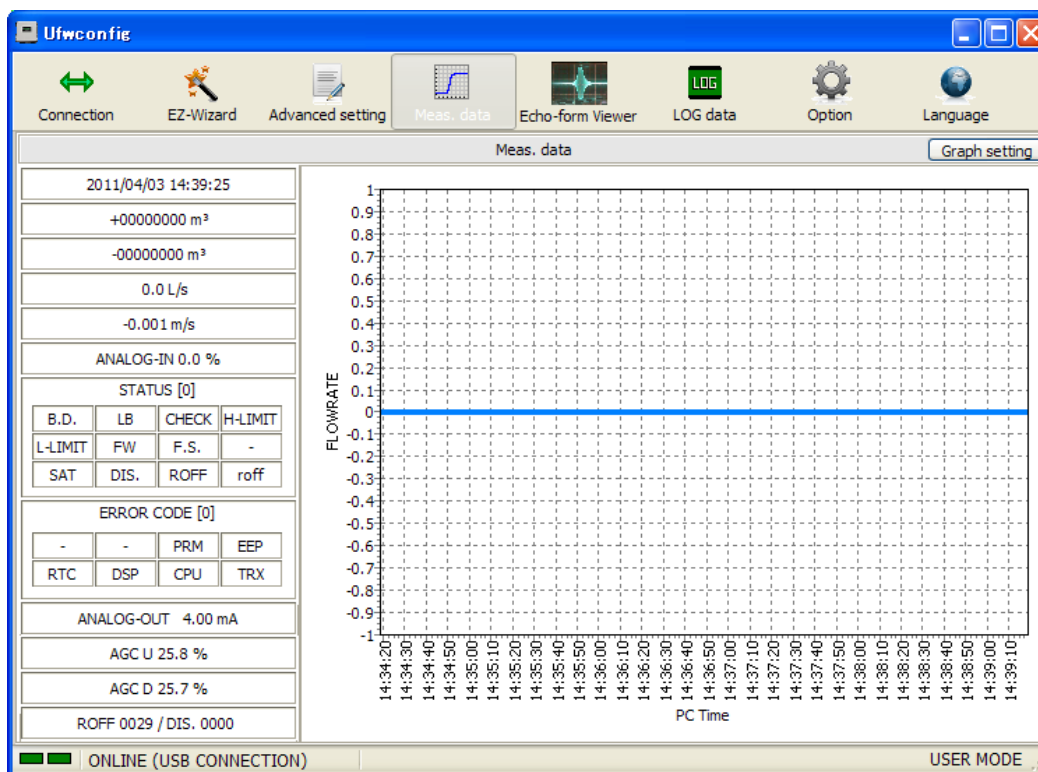

Button	Function
Graph setting	Axis, indicated value or trend graph clear can be selected.

2-2-3 Echo-form Viewer

When "Echo-form Viewer" is selected, following receiving Echo viewer will be shown.

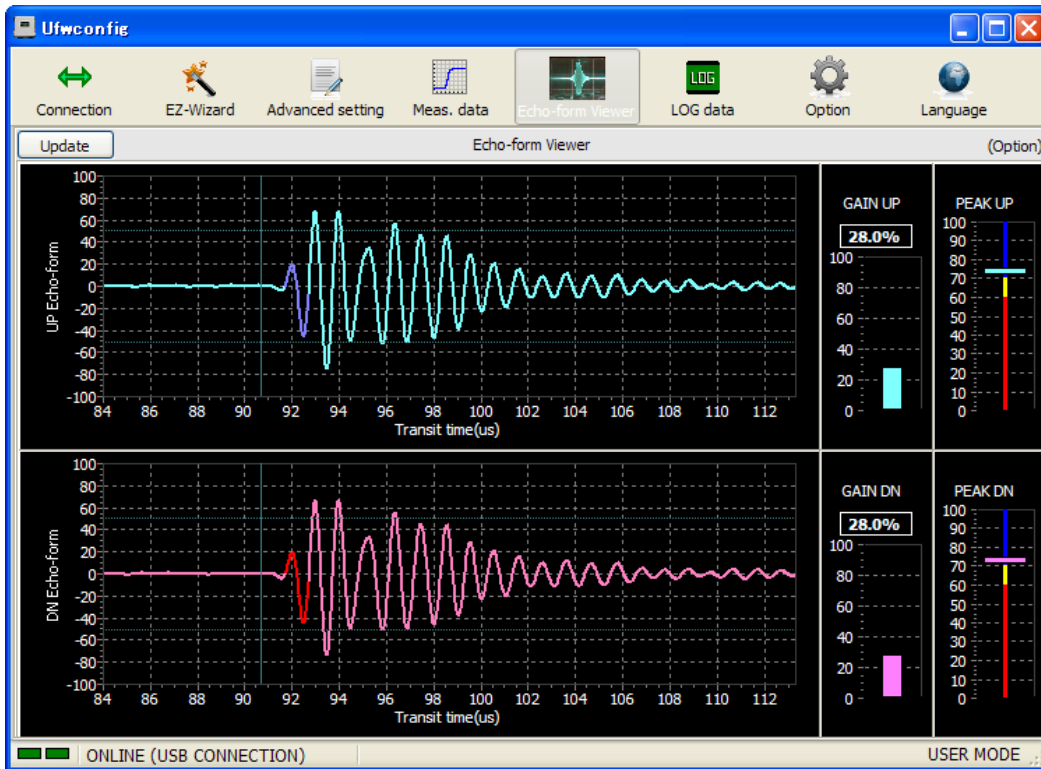

Button	Function
Update	Refresh latest receiving echo.

Amplitude gain will be adjusted automatically to keep proper level of echo. Following classification is typical reference.

Peak	Classification
70 to 100 (Blue)	Appropriate echo and location.
60 to 70 (Yellow)	Relatively low echo. Relocate mounting position or change to Z-path method to get proper echo.
0 to 60 (Red)	Very low echo. Relocate mounting position or change to Z-path method to get proper echo.

* This description is a typical reference. It may not be suitable for every actual application.

2-2-4 Downloading internal Logged Data

When "LOG data" is selected, Downloading internal Logged data Screen will be shown.

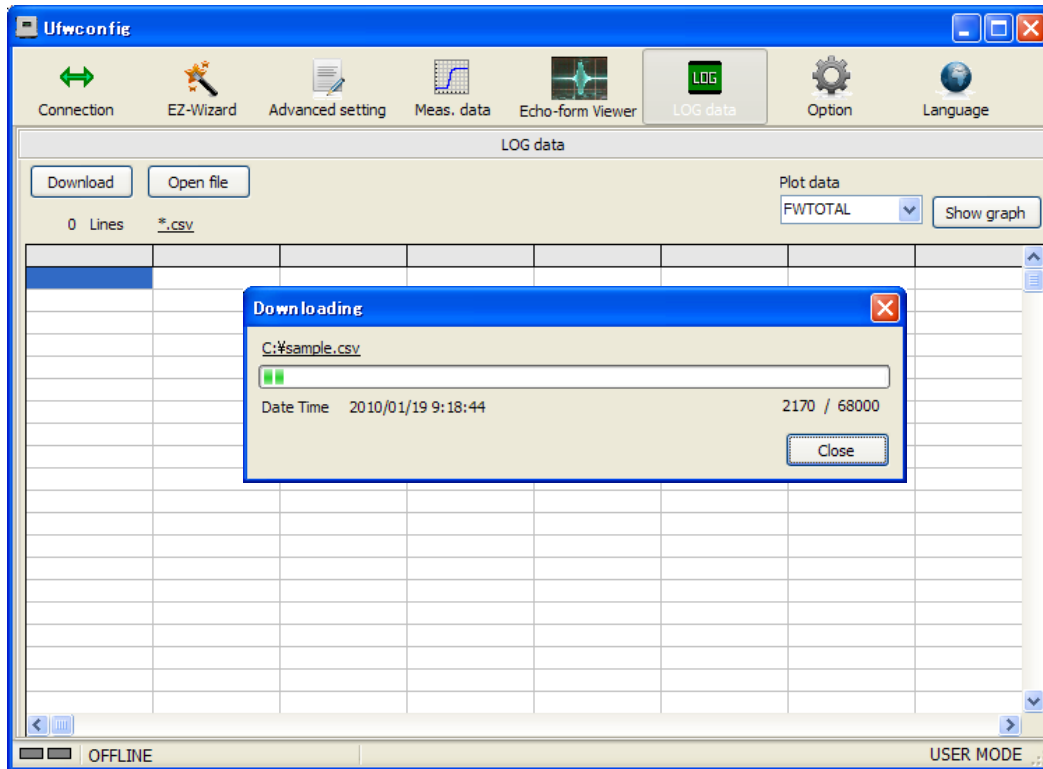

Button	Function
Download	Start down loading internal Logged data from main unit, after selecting file name and address. To quit downloading, please press "Close" button.
Open file	Open downloaded file from PC.
Show graph	To show trend graph of plotting data. Select designated column then Click "Show graph" button.

Sample data

```
DATE/TIME,FWTOTAL[L],BWTOTAL[L],FLOWRATE[L/min],VELOCITY[m/s],ANALOG-IN[%],STATUS,ERRCODE
2010/12/22 18:17:05,0000000,0000260,0.000,0.000,-25.11,64,0
2010/12/22 18:16:55,0000000,0000260,-1.144,-0.009,-25.11,0,0
2010/12/22 18:16:45,0000000,0000260,-0.915,-0.007,-25.11,0,0
2010/12/22 18:16:35,0000000,0000260,-0.688,-0.006,-25.11,0,0
...
```

NOTE

The unit of each value on the first line of Logged data is referred from latest parameter setting. If unit parameter has been changed during Logging, deviation will occur between measurement value and its unit.

2-2-5 Option

(1) Sound speed

In the option menu, the sound speed of water can be referred to in Metric or English units by selecting the specific system units box.

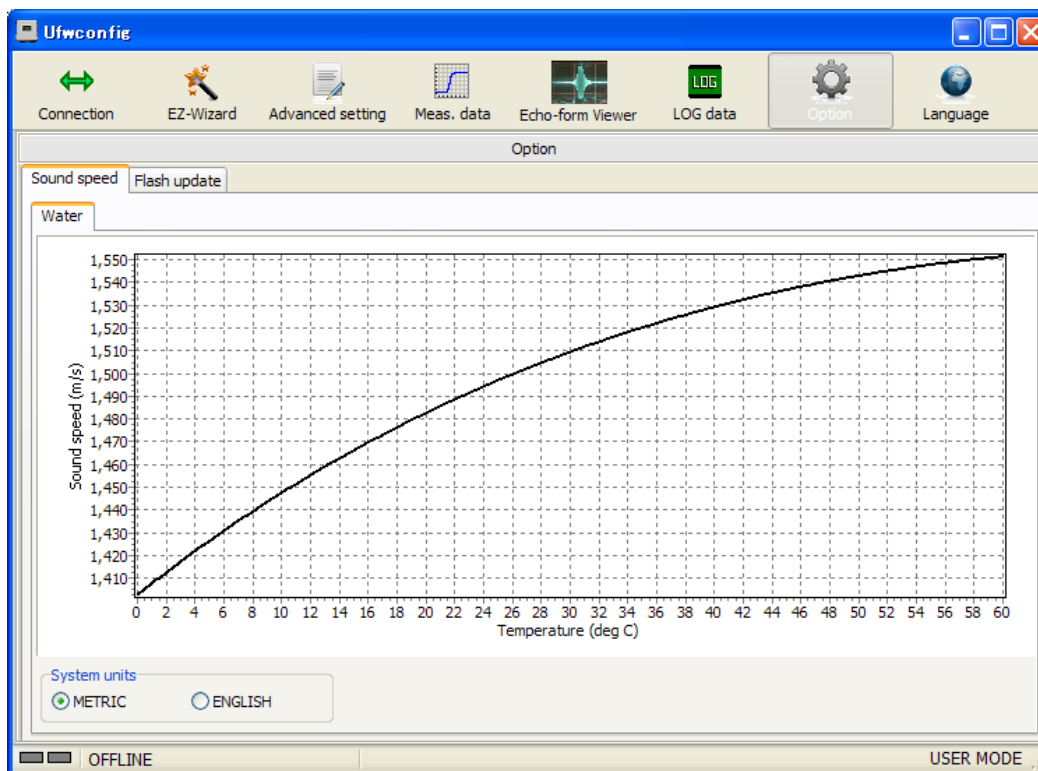

(2) Flash update

LF810 has capability to update its firmware through USB communication. It could be possible to keep the latest version of function by updating firmware. Please contact nearest dealership if you intend to update your LF810's firmware.

2-2-6 Language

This software has been designed in English. If another language is required on the PC, modifications will be needed. In the translation mode, any indicating characters on the PC can be input. Input designated translation word to each column and activate translation mode by following procedure. PC software will be shown by input language.

When you select the “Language” button in the main menu, detail setting related with translation is as shown below.

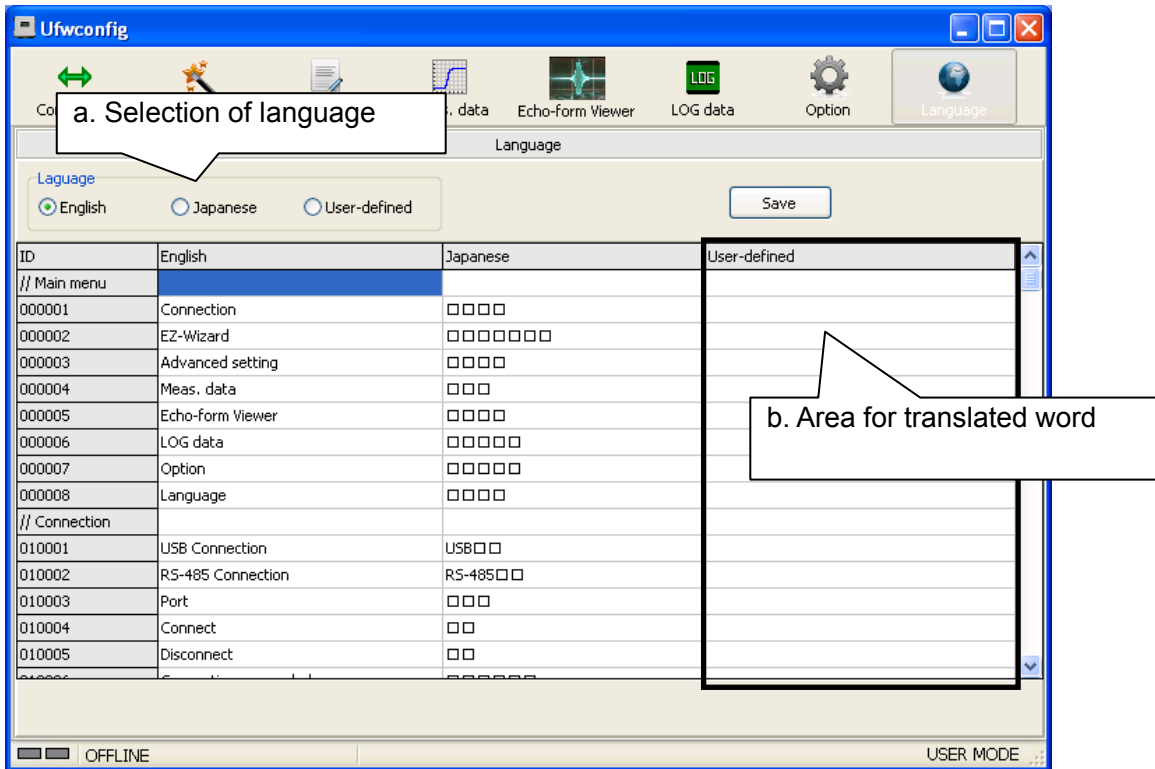

Conversion of indicated language

After you select “Language” from following 3 items, indication will be changed to the selected language.

1. English
2. Japanese
3. User-defined

Setting for User-defined

To use User-defined language, please input translated word converted from English to the area on the right column. In case the column is blank, English will be used.

When you click the SAVE button, “user-defined.lng” file will be generated in the same folder with “LF810Config.exe”. The “user-defined.lng” file is tab-delimited text format.

2-3 Parameter

Either of the parameters can be changed or viewed by PC software or 4 keys.

2-3-1 Site data

1- SITE

LCD menu	Symbol	Parameter	Setting range / selection items	Default
1-1	OD	Outside diameter	25.00 to 1500.00 mm (0.985 to 059.055 in)	114.00 mm
1-2	PM	Pipe material	(0)USER-DEFINED (User-defined) (1)STEEL (Steel) (2)DUCTILE IRON (Ductile iron) (3) [RESERVE] --- (4)COPPER (Copper) (5)STAINLESS (Stainless steel) (6)PVC (PVC) (7) [RESERVE] --- (8) [RESERVE] ---	(1)STEEL
1-2.1	PT	Pipe thickness	0.10 to 100.00 mm (0.004 to 3.397 in)	3.80 mm
1-2.2 (*1)	PSS	Pipe sound speed	500 to 9000 m/s (1640.5 to 29527.5 ft/s)	3200 m/s
1-3	LM	Lining material	(0)USER-DEFINED (User-defined) (1)NONE (None) (2)EPOXY (Epoxy) (3)MORTAR (Mortar) (4)RUBBER (Rubber) (5)PVC (PVC)	(1)NONE
1-3.1	LT	Lining thickness	0.00 to 100.00 mm (0.000 to 003.397 in)	0.00 mm
1-3.2 (*2)	LSS	Lining sound speed	500 to 9000 m/s (1640.5 to 29527.5 ft/s)	2480 m/s
1-4	TD	Transducer type	(1)SE104720T	(1)SE104720T
1-5	PATH	Installation method	(1)Z-PATH (Z-path method) (2)V-PATH (V-path method)	(2)V-PATH
1-6	CL	Cable length	0 to 030 m (0.0 to 098.4 ft)	5 m
1-7	FL	Fluid type	(0)USER-DEFINED (User-defined) (1)WATER (Water) (2) [RESERVE] ---	(1)WATER
1-7.1 (*3)	FLSS	Fluid sound speed	500 to 9000 m/s (1640.5 to 29527.5 ft/s)	1460 m/s
1-7.2 (*3)	FLVS	Fluid viscosity	0.01 to 900.00 x10 ⁻⁶ m ² /s (0.11~9687.52 x10 ⁻⁶ ft ² /s)	1.20
1-7.3 (*3)	FLDS	Fluid density	100.0 to 9000.0 kg/m ³	1000.0

Cancel parameter protection to change setting by key operation.

(*1) Use in case "User-defined" selected as Pipe material.

(*2) Use in case "User-defined" selected as Lining material.

(*3) Use in case "User-defined" selected as Fluid type.

(1) Pipe data setting

Set the outside diameter, material and thickness of the pipe on which the sensor is to be installed. When the pipe material cannot be found in the selection items, select "User defined" and set the pipe sound speed.

Set the lining material and thickness. When the lining material cannot be found in the selection items, select "User defined" and set the lining sound speed.

Pipe and lining sound speed data is provided in Chapter 3-4-3.

(2) Sensor data setting**a) Sensor type**

Select SE104720T.

b) Installation method

We recommend to select V-path method as typical installation. When calculated F-DIST for V-path method is negative value, F-DIST ERROR will be indicated. In that case, select Z-path method instead.

In case of following situation, select Z-path method even first time.

- When there is insufficient installation space.
- When ultrasonic waves do not propagate easily due to rust inside the pipe.
- Other cases when the sensitivity is poor.

c) Cable length

Set the sensor cable length. The upstream and downstream cables should be the same length. (The cable length is not used to calculate the sensor installation interval (F-DIST).)

(3) Fluid data setting

Select the fluid type. To set a fluid type that cannot be found in the selection items, select "User defined" and set the fluid data (sound speed, coefficient of kinematic viscosity, density). Fluid data is provided in Chapter 3-4-3 (3). The density is used to convert volumetric flowrate to mass flowrate when unit of mass is selected.

Notice

In case that selected "USER-defined" for pipe material and fluid is water. Please input actual velocity. Through PC configuration software, just need to input temperature of water.

(4) Transducer mounting information (F-DIST)

The sensor installation interval is calculated from the pipe, sensor and fluid data. When the main menu number 1 of the LCD menu is selected, the sensor installation interval (F-DIST) appears in the lower line of the LCD display.

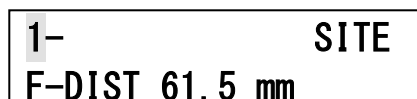

Fig. 2-3-1 Example of sensor installation interval (F-DIST) display

2-3-2 Flow units

2- FLOW UNIT

LCD menu	Symbol	Parameter	Setting range / selection items	Default
2-1	F.DPP	Flow decimal point position	(0)***** (1)*****. (2)****.* (3)***.* (4)**.*	(1)*****.
2-2	F.MULT	Flow multiplier	(0)u [1E-6] (1)m [1E-3] (2)x1 (3)k [1E3] (4)M [1E6]	(2)x1
2-3	F.VUNIT	Flow volume units (numerator)	(0)L/ (1)m ³ / (3)g/ (4)t/ (5)ft ³ / (6)bbl/ (7)gal/ (8)acf/	(0)L/
2-4	F.TUNIT	Flow time units (denominator)	(0)/sec (1)/min (2)/hour (3)/Day	(0)/sec

Cancel parameter protection to change setting by key operation.

(1) Flow units setting

Flow unit will be set combined with decimal point position, exponent, flow unit and totalizing unit. Please set decimal point to cover max. flow rate. Indicated digit of flow rate is 7 digits max.If more than 7 digits, "#####" will be indicated in LCD.

2-3-3 Correction

3- CORRECTION

LCD menu	Symbol	Parameter	Setting range / selection items	Default
3-1	ZSET	Zero point correction	-99999 to 999999 (Selected unit will be used)	0.0
3-2	SCOR	Span correction	00.001 to 20.000	1.000
3-3	LCUT	Flow volume cutoff	0 to 999999 (Selected unit will be used)	0.0
3-4	FILTER	Output filter	0 to 120 s	15 s

Cancel parameter protection to change setting by key operation.

(1) Zero point correction

Addition and subtraction to compensate for offsets in measurement values can be performed.

(2) Span correction

Measurement values can be corrected by an exponential coefficient.

The correction value is obtained by the following formula.

$$(\text{Value after correction}) = (\text{Span correction}) \times (\text{Measurement value}) + (\text{Zero point correction})$$

Fig. 2-3-3 shows the relationship between the measurement value and the correction values.

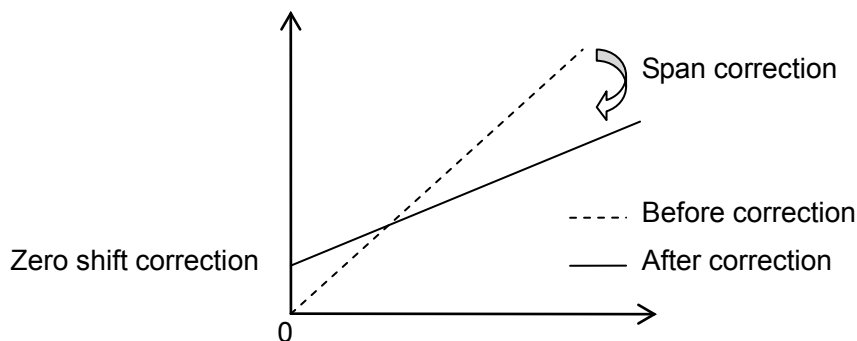

Fig. 2-3-3 Relationship between measurement value and correction values

(3) Flow volume cutoff

When the flow measurement value (the value after zero shift correction and span correction) is less than set value for “Low cut value” as absolute value, “0” flow will be imposed.

(4) Output filter

The filter strength is expressed by the time it takes to achieve 90% of measuring flow rate during stepped changes. When flow measurement values fluctuate greatly, dampening can be enhanced by increasing the filter setting. Specifically, increasing the filter setting dulls the response to flow changes. The setting unit is seconds, and the setting range is 0 to 120 seconds.

2-3-4 Alarm operation

4- ALARM

LCD menu	Symbol	Parameter	Setting range / selection items	Default
4-1	B.D.OPE	Breakdown operation	(0)HOLD (1)0% (2)100% (3)BURN OUT	(0)HOLD
4-2	ROFFOPE	ROFF operation	(0)HOLD (1)0% (2)100% (3)BURN OUT	(0)HOLD
4-3	LIMIT	Limit alarm	(0)OFF (1)ON	(0)OFF
4-3.1	H-LIMIT	Hi-limit alarm value	-99999 to 999999 (Selected unit will be used)	0.0
4-3.2	L-LIMIT	Lo-limit alarm value	-99999 to 999999 (Selected unit will be used)	0.0
4-4	MAXGAIN	Maximum gain	0 to 100 %	100 %

Cancel parameter protection to change setting by key operation.

(1) Breakdown(B.D.) operation setting

Set the measurement value and analog output value to be output in the event of a breakdown. The initial value is "HOLD" (the value before the breakdown (B.D.) continues to be output). The operation and measuring value output will be indicated in the Table2-3-4. Measurement operation during breakdown takes precedence over the no received signal operation setting.

(2) No received signal (ROFF) operation setting

Set the measurement value and analog output value to be output in the event of no received signal. The initial value is "HOLD" (the value before the no received signal judgment (ROFF) continues to be output). The operation and measuring value output will be indicated in the Table2-3-4. Measurement operation during breakdown takes precedence over the no received signal operation setting.

Table2-3-4 Operation setting in case of B.D. or ROFF

Item	Measurement value	Analog output
(0)HOLD	Hold	Hold
(1)0%	0	Current output set as flowrate 0.
(2)100%	Qmax of analog span (6-2 AO.S20)	20.0mA
(3)BURN OUT	0	20.8mA

(3) Limit alarm setting

Hi-Limit and Lo-Limit alarm will be available when Limit alarm is set. When flowrate will exceed Hi-limit alarm value, status will be H-LIMIT. If it will be below Lo-Limit alarm value, it will be L-LIMIT status.

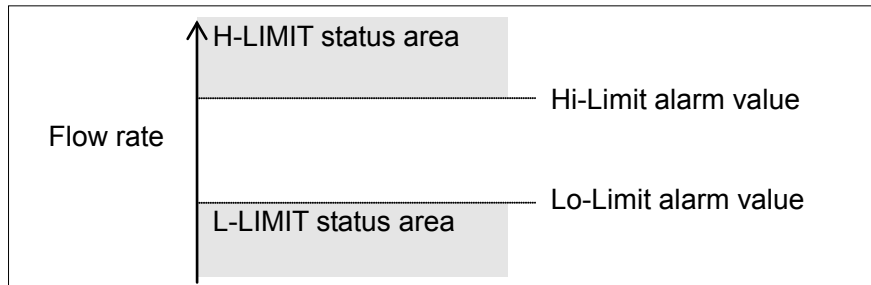

Fig. 2-3-4 Limit alarm

2-3-5 LCD display

5- LCD

LCD menu	Symbol	Parameter	Setting range / selection items	Default
5-1	LCD.1U	LCD Page 1 upper line	(0)FLOWRATE (1)VELOCITY (2)FW TOTAL (3)BW TOTAL (4)STATUS (5)ANALOG INPUT (6)ROFF CNT (7)DIS. CNT (8)GAIN U (9)GAIN D (10)DATE (11)TIME	(0)
5-2	LCD.1L	LCD Page 1 lower line	Same as 5-1	(1)
5-3	LCD.2U	LCD Page 2 upper line	Same as 5-1	(2)
5-4	LCD.2L	LCD Page 2 lower line	Same as 5-1	(3)
5-5	LCD.3U	LCD Page 3 upper line	Same as 5-1	(4)
5-6	LCD.3L	LCD Page 3 lower line	Same as 5-1	(5)
5-7	LCD.4U	LCD Page 4 upper line	Same as 5-1	(6)
5-8	LCD.4L	LCD Page 4 lower line	Same as 5-1	(7)
5-9	LCD.5U	LCD Page 5 upper line	Same as 5-1	(8)
5-10	LCD.5L	LCD Page 5 lower line	Same as 5-1	(9)
5-11	LCD.6U	LCD Page 6 upper line	Same as 5-1	(10)
5-12	LCD.6L	LCD Page 6 lower line	Same as 5-1	(11)

Cancel parameter protection to change setting by key operation.

Item	Description	Indication sample
(0)FLOWRATE	Flow rate	[0.0 L/s]
(1)VELOCITY	Flow velocity	[0.000 m/s]
(2)FW TOTAL	Forward flow totalized value	[+00000000 L]
(3)BW TOTAL	Backward flow totalized value	[-00000000 L]
(4)STATUS	Status code	[ST000000000000]
(5)ANALOG INPUT	Analog input	[0 %]
(6)ROFF CNT	ROFF Qty	[ROFF 0000]
(7)DIS. CNT	DIS. Qty	[DIS. 0000]
(8)GAIN U	UP Gain amplitude	[AGC U 30.0 %]
(9)GAIN D	DN Gain amplitude	[AGC D 30.0 %]
(10)DATE	Date (YY/MM/DD)	[2011/01/01]
(11)TIME	Time (hh:mm:ss)	[00:00:00]

(1) Measurement screen

Indication of LCD can be set by the following procedure.

LCD Indication

After the flowmeter is started up, the first page of the measurement screen, page1, is displayed. The page can be switched by pressing the [▲][▼] keys. Fig. 2-3-5 shows the switching operations and measurement screen transitions.

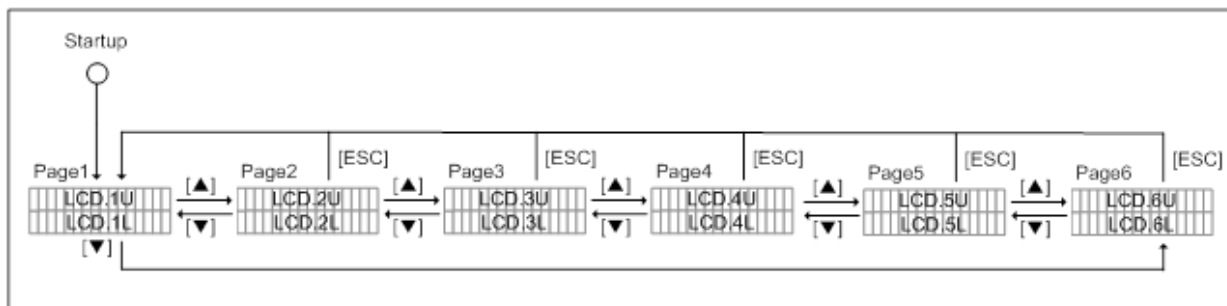

Fig. 2-3-5 Measurement screens

2-3-6 Analog output

6- ANALOG-OUT

LCD menu	Symbol	Parameter	Setting range / selection items	Default
6-1	AO.S04	4mA output	-99999 to 999999 (Selected unit will be used)	0.0
6-2	AO.S20	20mA output	-99999 to 999999 (Selected unit will be used)	100.0
6-3	AO.FS	Fit analog span	(0)OFF (1)ON	(0)OFF
6-4	AO.C04	4mA output calibration	3.500 to 4.500 mA	4.000
6-5	AO.C20	20mA output calibration	19.000 to 21.000 mA	20.000

Cancel parameter protection to change setting by key operation.

(1) Analog output pattern setting

4mA output: Input any flowrate for 4mA between the range.

20mA output: Input any flowrate for 20mA between the range.

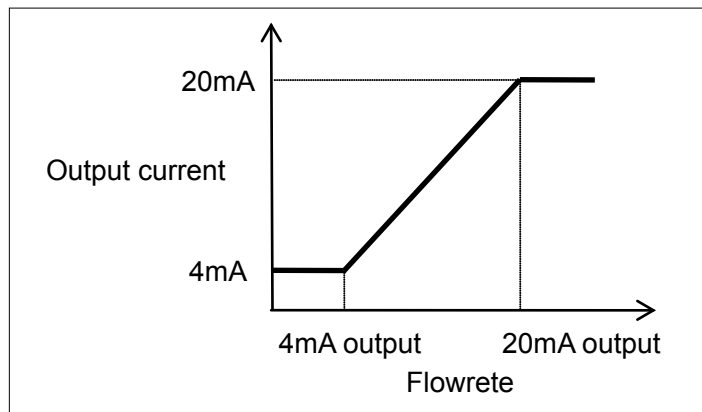

Fig. 2-3-6-1 Analog output pattern

(2) Fit analog span function

When "Fit analog span" is set as "ON", a measurement range is limited by the range set at an analog span.

When "Fit analog span" is set as "OFF", The measurement range is -30m/s to +30m/s as velocity.

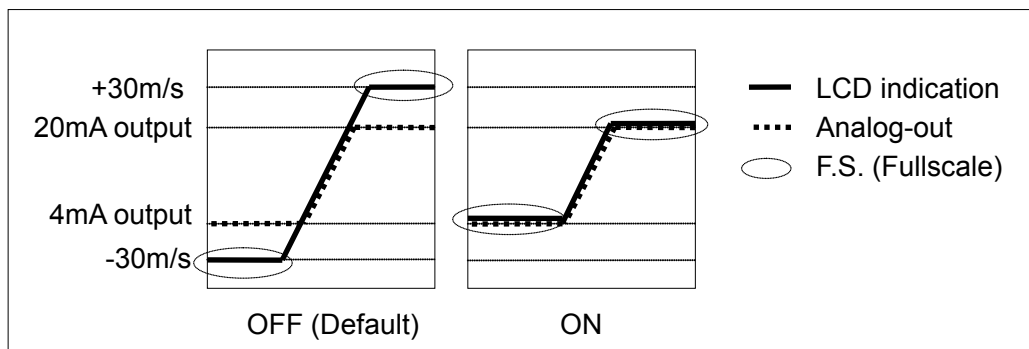

Fig. 2-3-6-2 Analog span fullscale function

(3) Analog output calibration

Analog output calibration has been performed at our factory. However, if necessary, the calibration can be performed according to the procedure described as follows :

a) Calibration method using the LCD menu

First, proceed to the 4 mA adjustment edit mode. Current of 4 mA is output from the analog output port. Measure the output current value using an ammeter or other instrument, and enter the measurement value. Next, proceed the 20 mA adjustment edit mode. 20 mA is output from the analog output port. Measure the output current value using an ammeter or other instrument, and enter the measurement value. This completes the analog output adjustment.

b) Calibration method using the LF810Config software

Check "Calibration" box, then click the [Calibration] button. The following message appears. Click the [OK] button.

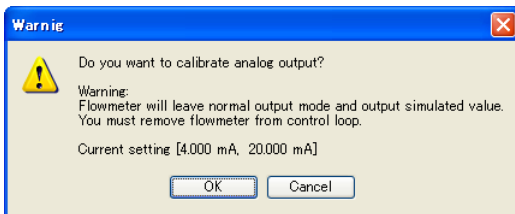

4 mA is output from the analog output port. Measure the output current value with an ammeter or other instrument, enter the measurement value, and click the [OK] button.

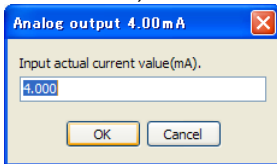

20 mA is output from the analog output port. Measure the output current value with an ammeter or other instrument, enter the measurement value, and click the [OK] button.

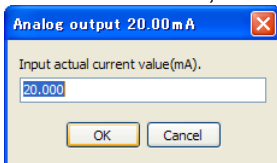

This completes the analog output calibration.

2-3-7 Contact output

7- CONTACT-OUT

LCD menu	Symbol	Parameter	Setting range / selection items	Default
7-1	CO.TYPE	Contact output	(0)BREAK (1)MAKE (2)FW-PULSE (3)BW-PULSE (4)ROFF (5)B.D. (6)B.D. OR ROFF (7)H-LIMIT (U-LIMIT) (8)L-LIMIT (9)FW-DIRECT	(0)BREAK
7-2	CO.PW	Totalized pulse width	(0)20ms (1)100ms (2)500ms (3)1000ms	(0)20ms
7-3	CO.INV	Logic inversion	(0)OFF (1)ON	(0)OFF

Cancel parameter protection to change setting by key operation.

(1) Contact output setting

The operational output can be selected from the following.

Item	Description
(0)BREAK	Contact always open.
(1)MAKE	Contact always closed.
(2)FW-PULSE	(Forward flow totalized pulse output) Totalized pulse output in the forward flow direction. The contact closes once each time the totalized count in the forward flow direction increments by 1.
(3)BW-PULSE	(Backward totalized pulse output) Totalized pulse output in the backward flow direction. The contact closes once each time the totalized count in the backward flow direction increments by 1.
(4)ROFF	(no receiving echo signal alarm) Contact closed when a no received signal alarm is generated.
(5)B.D.	(=Breakdown)(equipment failure) Contact closed when a breakdown alarm is generated.
(6)B.D. OR ROFF	Contact closed when either a no received signal alarm or a breakdown alarm is generated.
(7)H-LIMIT (U-LIMIT)	Contact closed when the upper limit value is exceeded. For backward flow the determination is based on the absolute value.
(8)L-LIMIT	Contact closed when the measurement value is below the lower limit value. For backward flow the determination is based on the absolute value.
(9)FW-DIRECT	Contact closed when there is flow in the forward flow direction.

(2) Totalized pulse width

The totalized pulse width should be selected from the value shown in table 2-3-7 when the contact output is set to FW-PULSE(forward flow totalized pulse output) or BW-PULSE(backward flow totalized pulse output).

NOTE
 Select the totalized pulse width taking into consideration the totalizing count-up rate. Set the totalized units so that the relationship between the pulse width 'a' and pulse interval 'b' is $a \leq b$ as shown in the figure below.

Table 2-3-7 Pulse width and maximum output rate

Pulse width	Max. output rate
20ms	25 pulses/sec.
100ms	5 pulses/sec.
500ms	1 pulses/sec.
1000ms	0.5 pulses/sec.

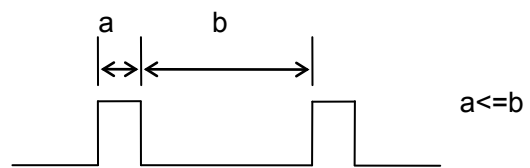

(3) Logic inversion

The contact logic is inverted. (The contact operates during 'a' when this function is set to OFF, or during 'b' when set to ON.)

2-3-8 Digital communication

NOTE

Digital communication is an optional specification.

8- DIGITAL-OUT

LCD menu	Symbol	Parameter	Setting range / selection items	Default
8-1	DO.OPTION	Status of Digital-comm. board	Read only (0)NONE (1)RS-485	—
8-2	DO.TYPE	Protocol type	(0)MODBUS-RTU	(0)
8-3	DO.ADRS	MODBUS slave address	0 to 247	0
8-4	DO.BPS	MODBUS baud rate	(0)4800BPS (1)9600BPS (2)19200BPS (3)38400BPS	(2)19200BPS
8-5	DO.PRTY	MODBUS parity	(0)NONE (1)ODD (2)EVEN	(0)NONE

Cancel parameter protection to change setting by key operation.

For detail description of Digital communication, please refer to Chapter 3-3-5 Digital communication specification.

(1) Status of Digital-comm. board

When RS-485 communication board is attached to main unit, "RS-485" will be shown. Otherwise "None".

(2) Protocol type

Only MODBUS-RTU is selectable.

(3) Address setting

Slave device address can be set by this column.

(4) Baud rate setting

Baud rate must be matched with Master Device.

(5) Parity setting

Parity must be matched with Master Device.

2-3-9 Analog input

NOTE
Analog input is an optional specification.

9- ANALOG-IN

LCD menu	Symbol	Parameter	Setting range / selection items	Default
9-1	AI.OPTION	Status of Analog-input board	(0)NONE (1)AIN	-
9-2	AI.TYPE	Analog input format	(0)% (1)mA	(0)%
9-3	AI.C04	4mA input calibration	(0)FINISH (1)CAL. (2)FACTORY	(0)FINISH
9-4	AI.C20	20mA input calibration	(0)FINISH (1)CAL. (2)FACTORY	(0)FINISH

Cancel parameter protection to change setting by key operation.

(1) Status of Analog-input board

When analog input board is attached to main unit, "AIN" will be shown. Otherwise "None".

(2) Analog input format

% or mA can be selectable for unit. If % unit is selected, 0% = 4mA and 100% = 20mA.

(3) Analog input calibration

Analog input calibration has been performed at our factory. However, if necessary, the calibration can be performed according to the procedure described as follows:

a) Calibration method using the LCD menu

When "CAL." is selected on the menu AI.C04 with analog input, main unit will calibrate 4mA input at site. As with the 20mA calibration, when "CAL." is selected on the menu AI.C20 with analog input, main unit will calibrate 20mA input at site. In either case, please select "FACTORY" to refresh and clear calibration value.

b) Calibration method using the LF810Config software

Check "Calibration" box. When "CAL." is selected on the menu as shown below with 4mA analog input, then push [Write] button and the confirmation notice will be shown. Then click OK and the calibration will be completed.

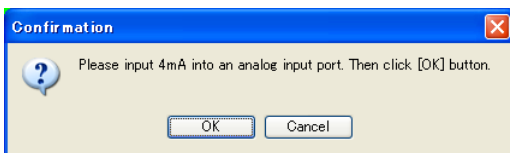

As with the 4mA calibration, 20mA calibration will be completed with the same procedure. In either case, please select "FACTORY" to refresh and clear calibration value by clicking OK, calibration value will revert to factory setting.

2-3-10 Log

10- LOG

LCD menu	Symbol	Parameter	Setting range / selection items	Default
10-1	INTERVAL	Log interval	0 to 3600 sec	60 s
12-2	LOGINIT	Log area initialize command	(0)NO (1)YES	(0)NO

Cancel parameter protection to change setting by key operation.

Measurement data with time and date are logged in the flowmeter's internal memory. The log data is retained by a protective battery even when the flowmeter is turned off.

Up to 68000 items of log data can be stored, including date and time, forward flow totalized value, backward flow totalized value, flow rate, flow velocity, analog input, conditions, and error codes. When log data exceeds 68000 items, the oldest data is overwritten with the latest values. Logged data can be transferred through LF810Config software by CSV-format.

NOTE

The life of the Internal Lithium battery, which is used for retaining Logged data, is about 5 years. Please pay close attention to "Low battery alarm"(B) on the LCD.

Logging function is working even during before parameter setting. After installation and commissioning, please clear Logged area prior to use.

(1) Log interval settings

The log interval can be set from 0 to 3600 seconds. When set to "0", log operation is stopped.

(2) Log area initialize

When "Log area initialize command" is set as "Yes", the All logged area will be cleared.

2-3-11 Totalizing

11- TOTALIZE

LCD menu	Symbol	Parameter	Setting range / selection items	Default
11-1	T.DPP	Total decimal point position	(0)***** (1)*****.* (2)*****.**	(0)*****
11-2	T.MUL	Total multiplier	(0)u [1E-6] (1)m [1E-3] (2)x1 (3)k [1E3] (4)M [1E6]	(2)x1
11-3	T.UNIT	Total units	(0)L (1)m ³ (2)g (3)t (4)ft ³ (5)bbl (6)gal (7)acf	(0)L
11-4	T.FWPRESET	Forward preset value	00000000 to 99999999 (Selected unit will be used)	0
11-5	T.BWPRESET	Backward preset value	00000000 to 99999999 (Selected unit will be used)	0
11-6	PRESET	Preset command	(0)NO (1)YES	(0)NO

Cancel parameter protection to change setting by key operation.

NOTE

The life of Internal Lithium battery, which is used for retaining Logged data, is about 5 years. Please pay close attention to "Low battery alarm"(B) on the LCD.

(1) Totalizing units settings

Totalizing value will be combined with measurement value, decimal point position, exponent and totalizing unit. Totalized value will be stored as an 8 digit integer. If either of above parameters, please clear internal logged value prior to use.

Pulse setting Example

1m³/pulse

11-1	Total decimal point position	(0)*****	LCD indication
11-2	Total multiplier	(2)x1	+0000000 m ³
11-3	Total unit	(1)m ³	

0.1m³/pulse

11-1	Total decimal point position	(1)*****.	LCD indication
11-2	Total multiplier	(2)x1	+0000000.0 m ³
11-3	Total unit	(1)m ³	

10m³/pulse

11-1	Total decimal point position	(2)*****.	LCD indication
11-2	Total multiplier	(3)k [x10 ³]	+000000.00 10 ³ m ³
11-3	Total unit	(1)m ³	

NOTE
 Number of Output pulse and Count-up of totalizing value will be matched. However, max. pulse ratio will be limited by pulse width.

(2) Totalizing value presets

When "Preset command" is set as "Yes", the flow total values will be preset to the values set in "Forward preset value" and "Backward preset value".

2-3-12 Check function

12- CHECK

LCD menu	Symbol	Parameter	Setting range / selection items	Default
12-1	FLW.CHK	Simulated flow check mode	(0)OFF (1)ON	(0)OFF
12-1.1	FLW.VAL	Simulated flow rate	-99999 to 999999 (Selected unit will be used)	0.0
12-2	AO.CHK	Analog output check mode	(0)OFF (1)ON	(0)OFF
12-2.1	AO.VAL	Analog output value	3.800 to 20.500 mA	4.000 mA
12-3	PLS.CHK	Contact pulse output check mode	(0)OFF (1)ON	(0)OFF
12-3.1	PLS.VAL	Number of output contact pulses	0 to 25 Hz	0
12-4	FIRMWARE	Firmware version	Display only	V*.***
12-5	R/D CLEAR	ROFF/DIS. counter clear command	(0)NO (1)YES	(0)NO
12-6	RESTART	Restart command	(0)NO (1)YES	(0)NO
12-7	INITIALIZE	Parameter Initialize command	(0)NO (1)YES	(0)NO

Cancel parameter protection to change setting by key operation.

(*1) Any parameters in the check function will be cleared to default values when power is turned on.

(1) Simulated flow check

When "Simulated flow check mode" is set as ON, measurement value will be replaced by simulated value. Analog output or Contact output operation can be checked.

(2) Analog output check

When "Analog output check mode" is as ON, it allows to input any values for analog check. Analog check will activate supreme to simulated mode.

(3) Contact pulse output check

When "Contact pulse output check mode" is set as ON, it allows to input number of pulse for pulse check. Pulse check will activate supreme to simulated mode.

(4) Firmware version

Firmware version can be checked.

(5) ROFF/DIS. counter clear

When "ROFF/DIS. counter clear command" is set as YES, the historical counter of ROFF or Disturbance will be cleared.

(6) Restart

When "Restart command" is set as YES, flowmeter will restart.

(7) Parameter initialize

When "Parameter initialize command" is set as YES, all parameters will be cleared to default value.

2-3-13 System

13- SYSTEM

LCD menu	Symbol	Parameter	Setting range / selection items	Default
13-1	PROTECTION	Parameter protection	(0)OFF (1)ON	(1)ON
13-2	SYSUNIT	System units	(0)METRIC (1)ENGLISH	(0)METRIC
13-3	DATE.FMT	Date format	(0)YYMMDD (1)MMDDYY (2)DDMMYY	(0)YYMMDD
13-4	DATE.SEP	Date separator	(0)/ (1)- (2).	(0)/
13-5	DATE	Date	00/01/01 to 99/12/31	-
13-6	TIME	Time	00:00:00 to 23:59:59	-
13-7	ID NO.	ID No.	00000 to 99999	00000
13-8	CODE	CODE	0000 to 9999	-

Cancel parameter protection to change setting by key operation.

(1) Parameter protection

"Parameter protection" is "ON" immediately after the flowmeter is turned on. To change the parameter settings, parameter protection must first be set to "OFF". After changing the parameters, it is recommended to set "Parameter protection" to "ON" again to prevent the parameter from being changed by mistake.

(2) System units

Metric and English units can be selected. Table 2-3-13 shows the correspondence between the units.

Table 2-3-14 Unit correspondence

Metric	English
mm	inch
m	ft
m/s	ft/s
$\times 10^{-6} \text{m}^2/\text{s}$	$\times 10^{-6} \text{ft}^2/\text{s}$

(3) Date and time setting

Set the system date and time. The date display format and division character can be set. The date and time set here are used as the date and time in the log data.

(4) ID No. setting

If required to set identification No. for each main unit, please set this parameter.

2-4 Status/Error code

2-4-1 Status

Measurement status bit table

BIT15	BIT14	BIT13	BIT12	BIT11	BIT10	BIT9	BIT8
0	0	0	0	B.D.	LB	CHECK	H-LIMIT
BIT7	BIT6	BIT5	BIT4	BIT3	BIT2	BIT1	BIT0
L-LIMIT	FW	F.S.	MC	SAT	DIS.	ROFF	roff

Item	Description	LCD
roff	"1" will be indicated when the momentum no receiving echo warning is generated.	-
ROFF	"1" will be indicated when No echo receiving warning .	[R] []
DIS.	Disturbance Air bubbles, debris or other solids in the measured fluid are detected. "1" when the disturbance elimination function operates.	[D] []
SAT	"1" will be indicated when the received signal waveform is saturated.	[S] []
MC	Maintenance code	-
F.S.	"1" will be indicated when the set measurement range is exceeded.	[F. S.] Flickering with F.S. mark and FS value.
FW	"1" will be indicated when flowrate is forward direction.	-
L-LIMIT	"1" will be indicated when the lower limit alarm is generated.	-
H-LIMIT	"1" will be indicated when the upper limit alarm is generated.	-
CHECK	"1" will be indicated during check operation.	[C] []
LB	"1" will be indicated when the battery power for log retention is low.	[] [B]
B.D.	Equipment failure (B.D.) "1" will be indicated When any B.D.occurs. Detail error content will be shown in error code.	[E] []

The order of precedence of the letters appearing in the upper right of the LCD display is as follows.

E > C > R > D > S

Sample of status code

Status	LCD	Description
DIS.	[ST00000000100]	BIT11 to BIT0 will be indicated "0" or "1". Left side starts BIT11, right side end is BIT0.

2-4-2 Error code

Status of error code indication

Status	LCD	Description
TRX error	Page1 [ERR-01 E] [TRX]	Error number will be shown at upper line. Error code will be shown at lower line.
	Page2 - Page6 [+00000000 L E] [-00000000 L]	E mark will be indicated right end at upper line.

Error Code List

Breakdown Part	PRM	EEP	RTC	DSP	CPU	TRX	Note
ID No.	32	16	8	4	2	1	B.D. = BreakDown
Error code							
ERR- 1						1	Transmitting and Receiving Circuit B.D.
ERR- 2					2		CPU B.D.
ERR- 4				4			DSP B.D.
ERR- 8			8				RTC RAM B.D.
ERR- 16		16					EEPROM B.D.
ERR- 32	32						Input Data Error
Example of Composite Error Codes							
ERR- 6				4	2		DSP & CPU B.D.
ERR- 20		16		4			EEP & DSP B.D.
ERR- 33	32					1	TRX & PRM B.D.

Item	Description
TRX	Transmitting and Receiving circuit diagnostics results.
CPU	CPU diagnostic results.
DSP	DSP diagnostics results.
RTC	Internal clock diagnostic results.
EEP	Setting data memory diagnostics results.
PRM	Parameter error is detected. Example of parameter error - Pipe inner diameter is negative value. - Parameter exceeds measurement range.

3. Other

3-1. Maintenance and Inspections

Electronic devices (electronic parts, etc.) such as the Ultrasonic Flowmeter may experience breakdowns due to age deterioration and other factors. Therefore, preventative maintenance and periodic inspection are important to implement beforehand to ensure long life and proper functioning of the Ultrasonic Flowmeter.

3-1-1 Main unit and transducer maintenance and inspection

**WARNING**

- Shut down the main unit and stop power supply to the system before performing maintenance or inspections to prevent electric shock.
- Use only the specified fuse.

- (1) Wipe away any dirt on the main unit and transducers with a soft cloth. Do not use paint thinner or other chemical products.
- (2) Inspect and clean the warning labels to ensure readability. Contact your TOSHIBA International Corporation representative when warning labels have become dirty and cannot be cleaned, or have peeled off.
- (3) Do not subject the main unit and transducers to shocks and impacts.
- (4) The main unit and transducers are designed to enable measurement even in bad weather, but long-term exposure to rain and wind may speed deterioration in performance. Therefore, avoid use in these environments if possible.
- (5) Even when a transducer fails, there is no change in external appearance except in extreme cases. Should failure or defect be suspected, contact your TOSHIBA International Corporation representative.

3-1-2 Lifetime of components

TOSHIBA International Corporation's Ultrasonic Flowmeter uses components with operational life expectancies. Periodic inspection of these components with attention to the following items is recommended. Contact your TOSHIBA International Corporation representative when any component replacement is required.

(1) LCD

The LCD used to display measurement values and other information has an operational life of approximately 5 years at the ambient temperature of 20°C. When this life is exceeded, the LCD contrast may darken or visibility may otherwise be affected, but the operational, flow measurement and output functions of the main unit are not affected. (Contrast is adjustable. Please refer to Chapter 2-2-1 "Basic operations, (1) LCD display and operating keys".) Generally, LCD life may be shortened when exposed to direct sunlight or used in high-temperature environments.

When the following phenomenon appears, it is failure of an LCD display.

A character becomes thin or a blot comes out.

An unnecessary character, a sign, a dot, etc. are displayed.

A dot display is missing.

Nothing is displayed.

Backlight becomes dark or goes out.

It is mislabeled and interfere with operation.

(2) Fuse

When the fuse blows, check for ground faults, short-circuits, insulation defects, and abnormalities in the power source. When no problems are detected, replace the blown fuse with the fuse specified by TOSHIBA International Corporation. Absolutely do not use a fuse with different ratings.

When all problems cannot be ruled out, or when replaced fuses continue to blow, contact your TOSHIBA International Corporation representative. (Recommended replacement cycle: about 3 years)

(3) Power supply unit

The power supply unit has an operational life of approximately 10 years at an average main unit ambient temperature of 40°C. The power supply life is determined by the life of the internal electrolytic capacitor. Generally, each 10°C increase in the ambient temperature is thought to shorten the life by half, and conversely each 10°C decrease in the ambient temperature is thought to double the life.

(4) Packing

The types of packing used in the Ultrasonic Flowmeter are as follows. The packing life differs according to the operating environment. Periodically inspect the packing to check for deterioration. When cracks, breaks or other problems are found, contact your TOSHIBA International Corporation representative for replacement, otherwise IP class performance cannot be maintained.

Location used	Material
Case packing (between the case and the cover)	Polyurethane
Cable gland packing	EPDM
USB connector packing	EPDM

(5) Internal arrester

The main unit incorporates an arrester to suppress indirect lightning surge due to lightning strikes and protect the internal electronic circuits. Direct lightning strikes and surges that exceed the rating may damage or degrade the arrester. In addition to lightning damage, the arrester may also be degraded in an environment that superposes the high-voltage surge generated from large power equipment onto the power supply line. While damage can be confirmed visually, it is difficult to visually determine degradation. Suppose lightning(induction lighting) occurs twice a year, service life expires in 5years.

(6) Lithium battery (for totalized value and log data backup memory)

The lithium battery used for the totalized value and log data backup memory has an operational life of approximately 5 years. Please be aware of the “B” mark (low battery warning) indicator appearing in the LCD display. In addition, this battery is needed only to retain the totalized values and log data when the power is cut off, so even in the event the battery is completely discharged, the operational, flow measurement and output functions of the main unit are not affected.

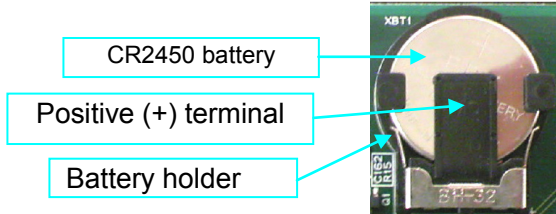
⚠ WARNING	
<ol style="list-style-type: none"> 1. Use only the specified battery. 2. Do not short-circuit the positive (+) and negative (-) terminals of the battery (for example, do not handle with metal tweezers or use other metal objects). 3. Do not recharge the battery. 4. Insert the battery with the polarity (+)(-) correctly. 5. Dispose of used batteries promptly. When disposing of the battery, take care to isolate the positive (+) and negative (-) terminals of the battery to prevent a short-circuit.1. 	
⚠ CAUTION	
Do not drop the battery, as this may deform or damage the battery.	
Lithium battery specifications	Battery polarity indication
Coin-type Lithium battery Model: CR2450 Rating: 3 V, 600 mAh	

3-2 General Specifications

3-2-1 Overall

Measurement	Fluids	Homogeneous and ultrasonically conductive fluids (Clean water, waste water, industrial water, river water, sea water, pure water, etc.)
	Temperature range	-20°C to +60°C Note: 1) above also applicable to ambient temperature 2) For main unit, -10°C to +50°C
	Turbidity	10000 mg/L or less Note) No air bubbles
Pipes	Material	Pipes made of materials that allow stable transmission of ultrasonic waves, such as steel, stainless steel, ductile cast iron, PVC, etc. Note) Applicable pipe bores may vary depending on the pipe material and condition.
	Diameters	DN25mm to DN600mm
	Lining	None, tar epoxy, mortar, etc. Note) Linings must be closely adhered to the base pipe.
Measurement range	Converted to flow velocity: -30 m/s to +30 m/s	
Number of measurement paths	1 measurement path	
Measurement cycle	1 s	
Measurement Performance	DN 25 ~ 40mm	±2.5%(*) of reading, however ±0.025(*) m/s for flow velocities less than 1 m/s (*) Depending on calibration
	DN 50 ~ 90mm	±2.0% of reading, however ±0.020 m/s for flow velocities less than 1 m/s
	DN 100 ~ 250mm	±1.5% of reading, however ±0.015 m/s for flow velocities less than 1 m/s
	DN 300 ~ 600mm	±1.0% of reading, however ±0.010 m/s for flow velocities less than 1 m/s
	Repeatability	±0.5%
	Range ability	1 : 300
	Note:	1) For volumetric flow rate. 2) Fully developed and rotationally symmetrical flow profile required. 3) Verified by manufacturer's conditions.
Measurement method	Ultrasonic pulse transit time difference method	

European compliance (CE marking)	EMC Directive 2004/108/EC Harmonized Standard / EN61326-1:2006 + EN61326-2-3:2006 Separation into group / Group I, Division into classes / Class A Location intended for use / In industrial locations Low Voltage Directive 2006/95/EC Harmonized Standard / IEC61010-1:2001 Over voltage category II, Pollution degree II, Altitude up to 2000m
NRTL Approval	UL 61010-1 / TUV-SUD Approval (Expansion boards(AIN-10 and 485-20) are not certificated in NRTL.)

3-2-2 Main unit

Analog output	St'd/option	Standard
	Number of channels	1
	Output contents	Instantaneous flow rate value
	Output format	4 - 20 mA, 20.8 mA when burnout occurs Max. allowable load resistance 600 Ω, Insulated outputs
	Accuracy	±0.2% F.S.
	Terminal panel	Screw less Terminal (0.08~2.5mm ² cable applicable)

Contact point output	St'd/option	Standard
	Number of channels	1
	Output contents	Selectable from: <ul style="list-style-type: none"> - Forward flow totalizing pulse - Backward flow totalizing pulse - No receiving echo warning(ROFF) alarm - Breakdown(B.D.) alarm - No receiving echo warning or breakdown alarm - Hi-Limit alarm - Lo-Limit alarm - Forward flow identification - Always open - Always closed Note) 1) Pulse width of contact is selectable from 1000, 500, 100, 20ms. 2) Each default setting is "ON" at work, but "OFF" at work is also selectable.
	Output format	Photo coupler (insulated)
	Contact point capacity	48Vdc, 0.4A
	Terminal panel	Screw less Terminal (0.08~2.5mm ² cable applicable)

USB communication	St'd/option	Standard
	Number of channels	1
	USB Cable length	Up to 3m
	Functions	Flowmeter programming, measurement value display, received signal waveform display, and log data readout using dedicated software*1 *1 Compatible with Windows 7, Vista and XP
	Connector	USB-B terminal, hot plug possible

Digital communication	St'd/option	Option
	Number of channels	1
	Format	RS-485 (insulated type)
	Protocol	MODBUS-RTU compatible
	Transmission length	Up to 1km 1)Transmission length depends on cable and communication speed.
	Data	Forward flow totalized value, backward flow totalized value, instantaneous flow rate, instantaneous flow velocity, equipment status, etc. Refer to Chapter3-2-7 Digital communication specification.
	Baud rate	4800, 9600, 19200, 38400 bps (Selectable)
	Parity	None, Even, Odd (Selectable)

	Data bit length	8 bit /1 stop bit
	Terminal panel	Screw less Terminal (0.08~2.5mm ² cable applicable)

Analog input	St'd/option	Option
	Maximum number of channels	1
	Input format	4-20mA, Input resistance 300 Ohm or less
	Data type	Selectable from (%) or (mA) for logging
	Terminal panel	Screw less Terminal (0.08~2.5mm ² cable applicable)

Log function	St'd/option	Standard
	Log contents	Date and time, forward flow totalized value, backward flow totalized value, instantaneous flow rate, instantaneous flow velocity, analog input value, measurement status, error status
	Number of log entries	68000 entries
	Log method	Ring buffer method
	Log cycle	Setting range: 0 to 3600 s, Default 60s 1.5 months or more at a 60 s cycle (60 entries x 24 hours x 45 days = 64800 data) 1 year or more at a 600 s cycle
	Data retrieval	Logged data can be transferred through LF810Config software by CSV-format.

Data setting	Setting method	LCD 4-keys entry or USB communication setting through PC with LF810Config software.
--------------	----------------	---

Display	Display method	LCD (16 characters x 2 lines), with backlight
	Display content	<ul style="list-style-type: none"> - Flow rate value and units - Flow velocity value and units - Forward flow totalized value and units - Backward flow totalized value and units - Status code - Analog input value (*Option) - ROFF counter value - DIS. counter value - Upside gain amplitude - Downside gain amplitude - Date - Time
	Display digits	Flowrate: Max. 7 digits (including sign and decimal point) Flow velocity: Max. 7 digits (3-digit decimal section) Totalized value: 8 digits
	Status	<p>Symbols are displayed at the right side of LCD.</p> <p>"C" Check operation underway (upper line of the LCD)</p> <p>"E" Error occurred (upper line of the LCD)</p> <p>"R" No received signal warning (upper line of the LCD)</p> <p>"D" Disturbance detection (upper line of the LCD)</p> <p>"B" Low Coin battery (lower line of the LCD)</p> <p>During exceeding Max. range of flow rate for Analog output setting, indication would be "Instantaneous flow rate" and alternated flickering with "FS" (Full Scale) mark.</p>

Units	Flow rate units	<ul style="list-style-type: none"> - Multiplier u ($\times 10^{-6}$), m ($\times 10^{-3}$), x1, k ($\times 10^3$), M ($\times 10^6$) - Flow volume units L/, m³/, g/, t/, ft³/, bbl/, gal/, acf/ - Flow time units /s, /min, /h, /D
	Totalizing units	<ul style="list-style-type: none"> - Multiplier u ($\times 10^{-6}$), m ($\times 10^{-3}$), x1, k ($\times 10^3$), M ($\times 10^6$) - Decimal point position ***** (x1), *****.* (x0.1), *****.** (x0.01) - Units L, m³, g, t, ft³, bbl, gal, acf

Functions	Low flow cutoff	Cuts (zeros) flows when flow falls below prescribed instantaneous flow rate. Used in order to avoid output of flow values other than 0 when measurement value during still flow becomes disordered.
	No Echo receiving warning	<p>If measurement cannot be made when no echo is received continuously over the setting time (determined transition time), status is changed to</p> <ul style="list-style-type: none"> - Display "R" on LCD - Selected ROFF operation - Contact output of warning if set. - Count up as history on ROFF counter
	Disturbance detection	<p>Check whether processing values are measured properly or not and if determined to be disturbed conditions, then measuring values are eliminated.</p> <ul style="list-style-type: none"> - Display "D" on the display - Count up as history on DIS. counter
	Zero point correction	Zero point can be compensated (shifted) for flow rate.
	Span correction	Slope of span line can be corrected for flow rate.
	Output filter	<p>Rapid flow rate changes would be smoother by this filter. Note) This value signifies the time until measuring flow rate reaches 90% by step-up increment.</p>
	Self-diagnostics and failure processing	<p>If failure is diagnosed on the following items, -</p> <ol style="list-style-type: none"> 1) Transmitting and receiving circuit 2) CPU diagnostic 3) DSP diagnostic 4) Internal clock diagnostic 5) Setting data memory diagnostic 6) Parameter setting data diagnostic <ul style="list-style-type: none"> - Selected B.D. operation - Display "ERR-**" on LCD. (** is error number.) - Contact output of warning if set.

	Data retention	Totalized flow values and all setting parameters are retained in memory with lithium battery even if there is a power failure. Note: 1) Setting parameters are retained in nonvolatile memory. 2) Totalized flow value, Logged data and ROFF/DIS. history are retained in memory and held by Back-up Battery. 3) Data retained in memory and held by Back-up Battery clears if battery is removed without power supply. 4) 5 year life at room temperature. 5) No battery recharging function.
	Check function	- Simulated flow check mode - Analog output check mode - Totalized pulse output check mode
	Automatic gain control (AGC)	Receiver can be set as ideal amplitude automatically.
	Totalized value preset	Totalized value can be freely preset.

Power supply	100 to 230Vac±10%, 50/60Hz±2Hz Option: 24dc±20% (This option must be pre-selected)	
	Momentary outage	AC input: 20ms DC input: 0ms
Power consumption	100Vac: 19VA, 200Vac: 23VA 24Vdc: 9W (Option)	
Fuse	AC: IEC 60127-2 SS5, Cartridge fuse-links, φ 5.2x20 mm Rating 2A/250V, Time-lag, High Breaking Capacity (1500A) DC: IEC 60127-2 SS5, Cartridge fuse-links, φ 5.2x20 mm Rating 4A/250V, Time-lag, High Breaking Capacity (1500A)	
Rush current	Less than 15A at 100Vac / Less than 25A at 200Vac Less than 15A at 24Vdc(Option)	
Operating temperature range	-10 to +50°C	
Storage temperature range	-20 to +60°C	
Operating humidity range	Less than 90% RH, non-condensation	
Main unit protection class	IP65	
Wiring connection ports	I/O and power ports: PG13.5 x 3, applicable cable diameter 7 to 12.5 mm Sensor ports: PG9 x 2, applicable cable diameter 4.5 to 8 mm Other: USB-B female type for USB communication x 1	
Main unit case material	ABS (Color: white gray)	
Weight	Approx. 2.1 kg	
Dimensions	210 (W) x 210 (H) x 100 (D) mm, not including protrusions	

3-2-3 Transducer

Transducer	SE104720T
Temperature range	-20~60°C
Protection class	IP65 (When filled with resin by the installer) IP67 as an option (Resin-filled product, shipped with cable connected)
Compatible cable	RG-223/U
Maximum cable length	30 m

3-2-4 Optional parts

IP67 detector	Shipped from the factory with a 30 m cable connected	
Power cable (*1)	St's/option	Prepared by user
	Model name	OLFLEX Classic 100 multi-conductor, flexible power and control cable
	Part number	10060
	Manufacturer	LAPP KABEL
	Details	3 conductors AWG16, 1.5 mm ² Nominal outer diameter 8.1 mm
Mounting plate	For wall mounting or standard pipe (DN50mm) mounting (Fig. 1-2-3-3) Consist of: Mounting plate, U bolt, Wing nut, Spring washer, Flat washer, screw M4.	
Expansion board AIN-10 (*2)	Analog input: Insulated passive input type	
Expansion board 485-20 (*2)	Digital communication functions Insulated RS-485, MODBUS-RTU compatible	

(*1)Power cable is specified in case of complying with EC directive.

(*2)Expansion boards can be mounted simultaneously.

3-2-5 Type Specification Code

Model number table

Model number					Specification code				Contents
1	2	3	4	5	6	7	8	9	
L	F	8	1	0					ULTRASONIC FLOWMETER
					A D				Power supply 100-230Vac,50/60Hz 24Vdc±20%
						A B			
								0 1 2 3	I/O card ※3 No need
									Rs-485 Modbus Communication Card
									Analog Input Card(1ch)
									Both of RS-485 Modbus and Analog Input
								A B	Mounting for Main unit
									Mounting plate no need (With mounting feet for wall) ※4 Mounting plate(wall or DN50mm stand pipe)

- ※1 Coaxial cables(RG-223/U) needs to be prepared.
Please choose a coaxial cable from the following table.
- ※2 Detectors is shipped from the factory with a 30 m cable connected.
- ※3 Expansion boards can be mounted simultaneously.
Before arrangements, determine existence selection of an option board.
After shipment, the option addition cannot be performed.
- ※4 Even if there is no mounting plate, there are four mounting feet.
A main unit is attached at wall like the 103 pages.

• Coaxial cables

Code						Contents
1	2	3	4	5	6	
C	C	L	0			Length ※5
				0	0	Without cable ※6
				0	5	5m
				1	0	10m
				1	5	15m
				2	0	20m
				2	5	25m
				3	0	30m

- ※5 Since the number of detectors is two, two coaxial cables are also required for them.
By this selection, it becomes two coaxial cables per each length.
- ※6 Coaxial cables(RG-223/U) needs to be prepared as a cable by customer.

3-2-6 Dimensions

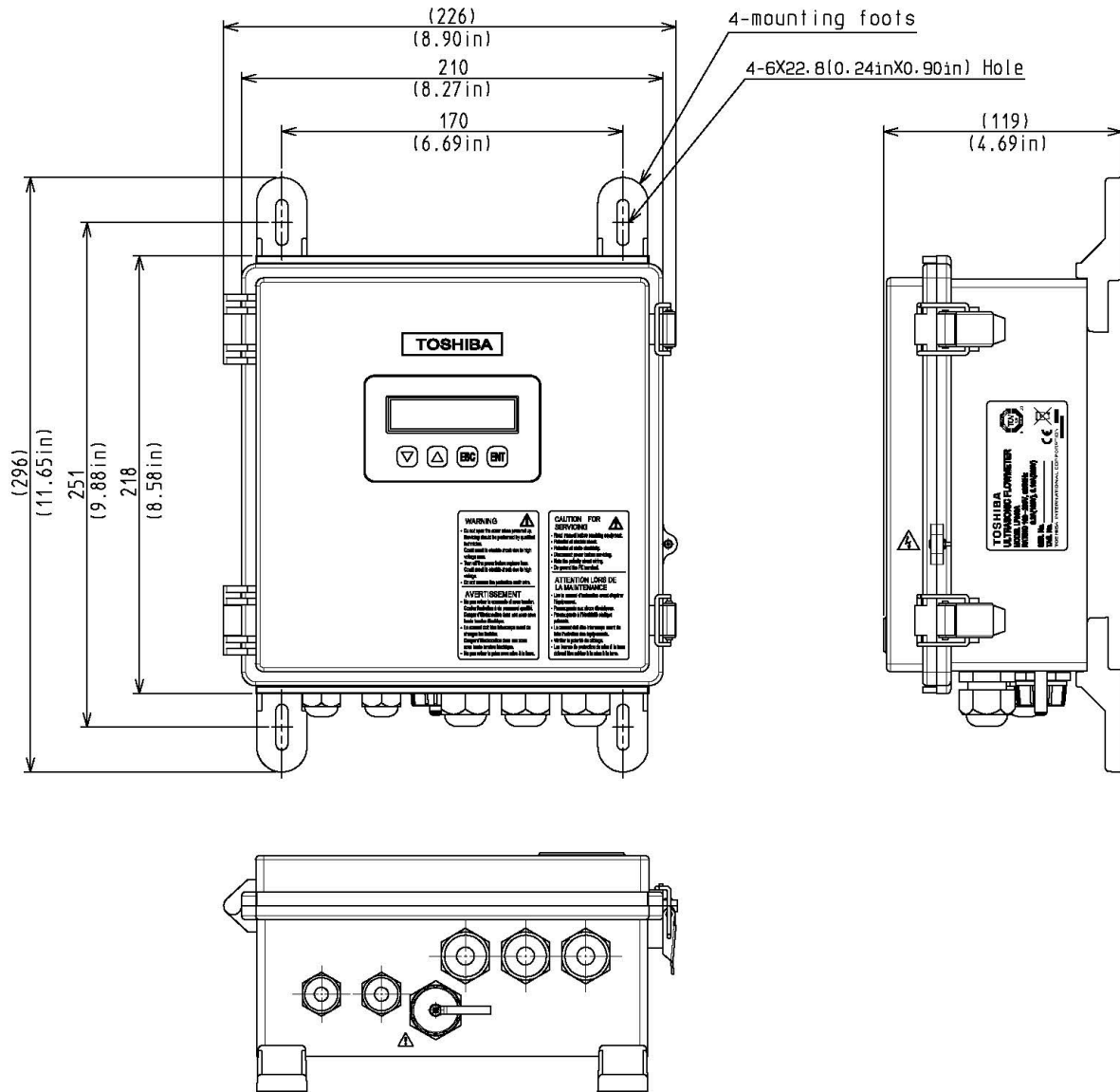

Fig. 3-2-6-1 Main Unit (with mounting feet)

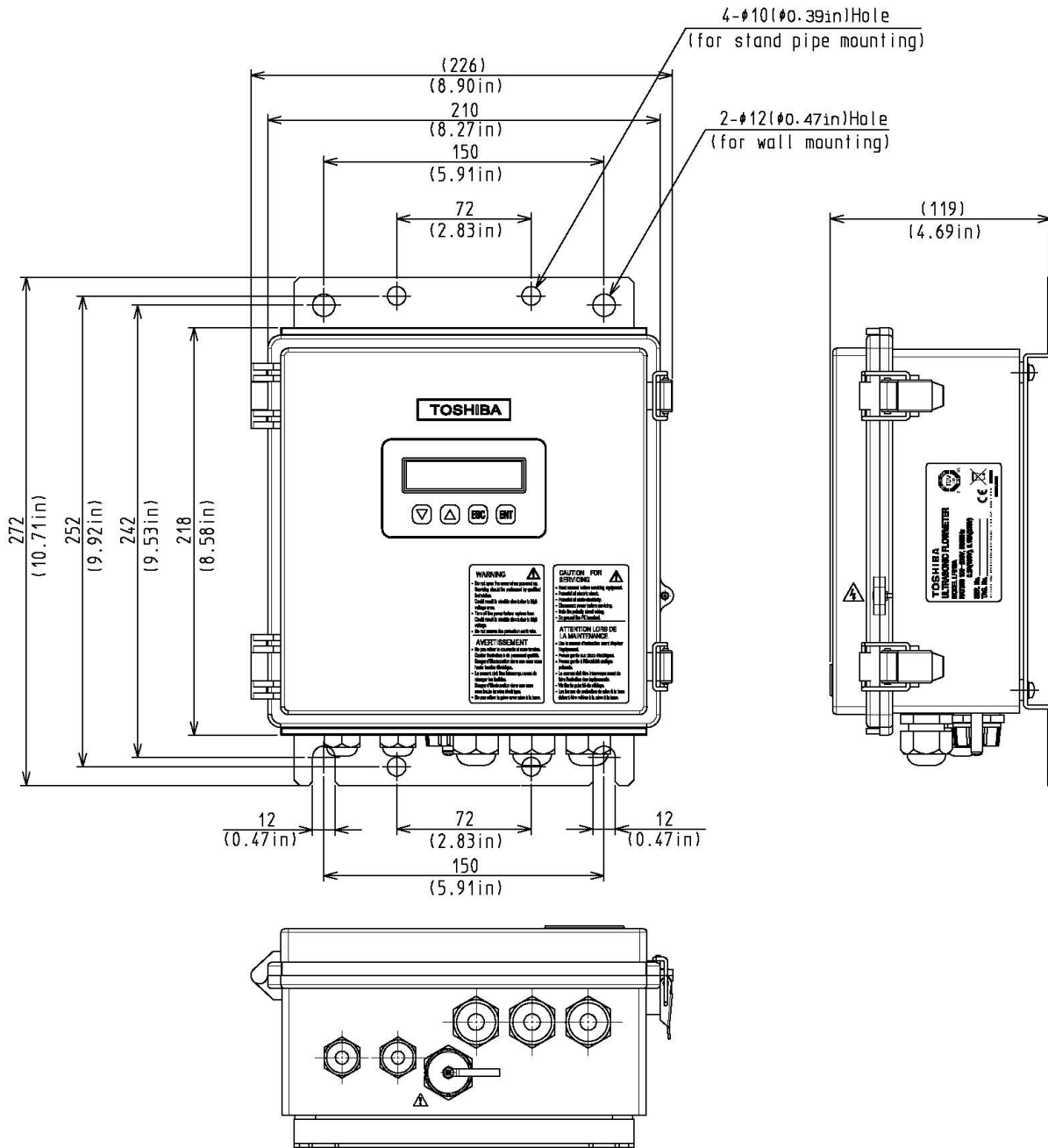

Fig. 3-2-6-2 Main Unit (with mounting plate)

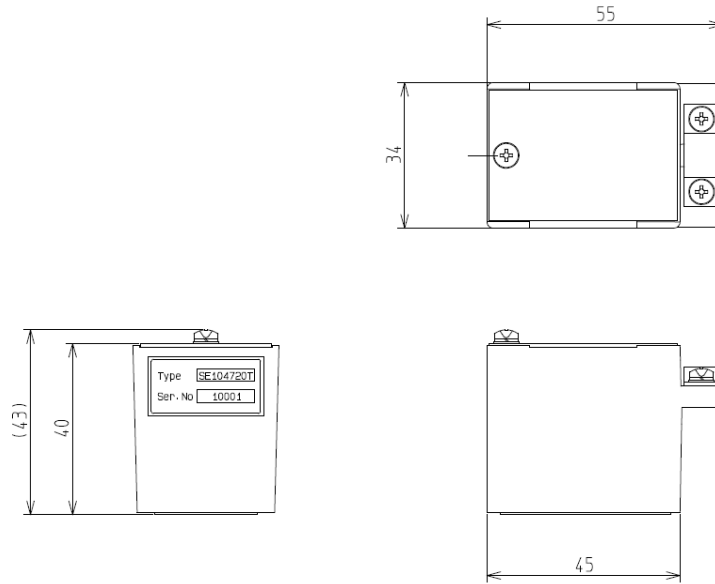

Fig. 3-2-6-3 Transducer

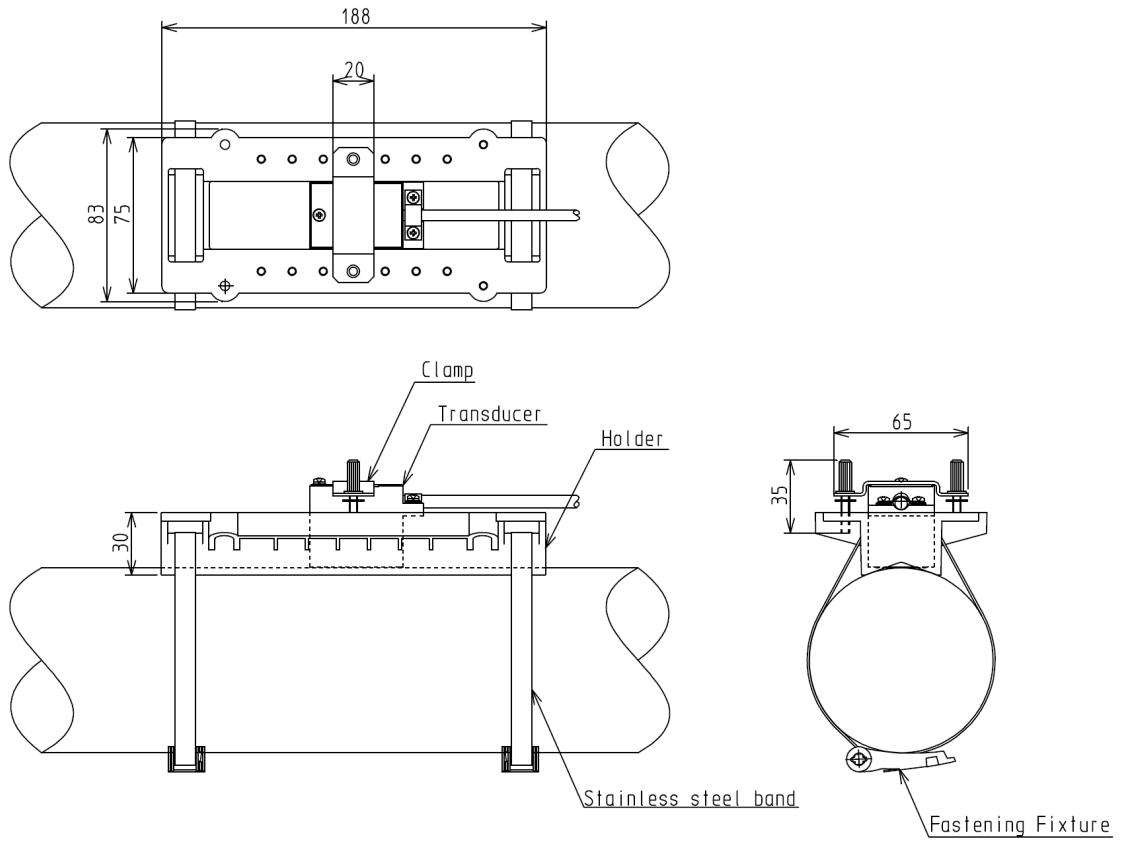

Fig. 3-2-6-4 Mounting Fixture for Transducer

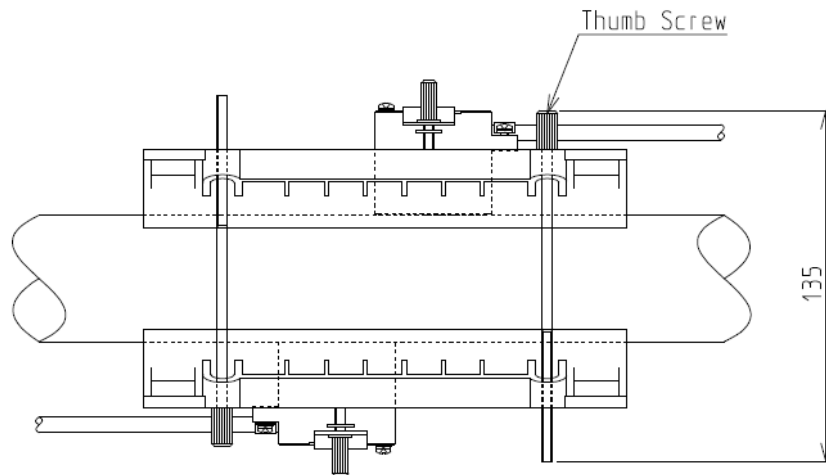

Fig. 3-2-6-5 Mounting Fixture for Transducer (Z method)

3-2-7 Digital communication specification (Option)

1. Overview

Flow rate, velocity, totalizing value, status can be monitored by adding optional digital board. Specification of digital communication is as follows:

To download the logged data and waveform data without using the configuration software, please consult manufacturer.

Table 3.2.7 Digital communication specification

Electrical specification	RS-485 half duplex	
	Communication length	Up to 1km (*1)
	Max. connectable unit	Up to 31 (*1)
	Baud rate	4800bps 9600bps 19200bps (Default) 38400bps
	Parity	None (Default) Odd Even
	Data format	Bit length 8 Stop bit 1
	Terminal	WAGO255
Protocol	MODBUS-RTU	
	Mode	RTU mode (*2)
	Error check	CRC error check
	Slave address	0 to 247 (Default 0)

(*1)Communication length depends on cable and baud rate. Shielded twist pair cable is recommended. In case of long distance communication, AWG24 or higher grade cable will be required.

(*2)TEXT mode is not applicable.

2. Wiring Connection

The terminal of digital communication is as shown below. For wiring connection, remove sheath 6mm from the cable, then insert cable tip to terminal, and push attached lever by screw driver.

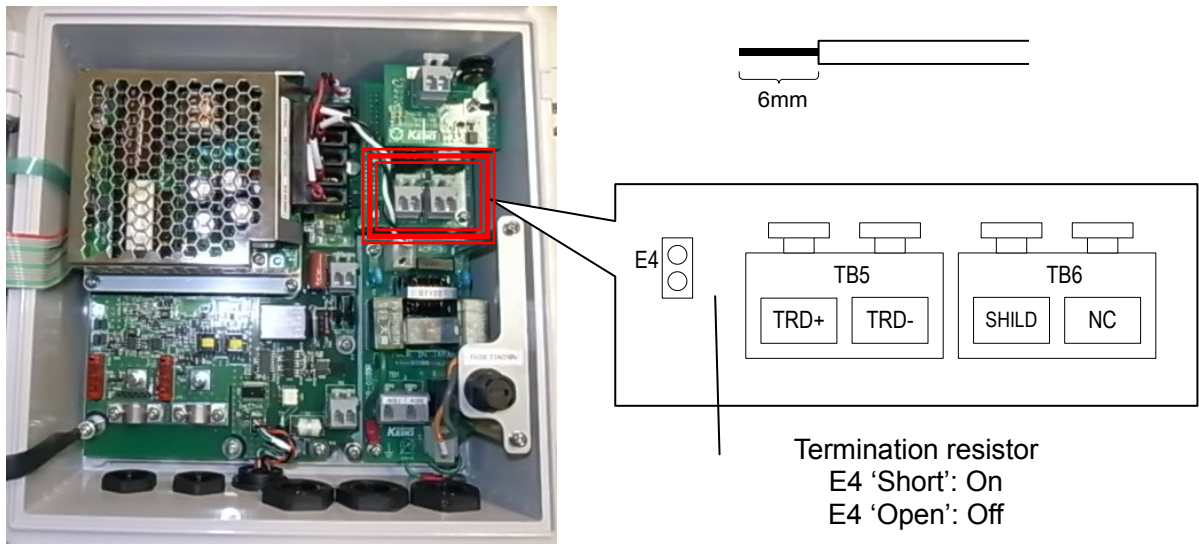

In the case of a multi-drop connection as shown below in Fig. 3-2-7, the wiring between each device must be as short as possible. A termination resistor will be required at each end of the network. To activate the termination resistor, Jumper 'E4' must be in place, otherwise remove the jumper.

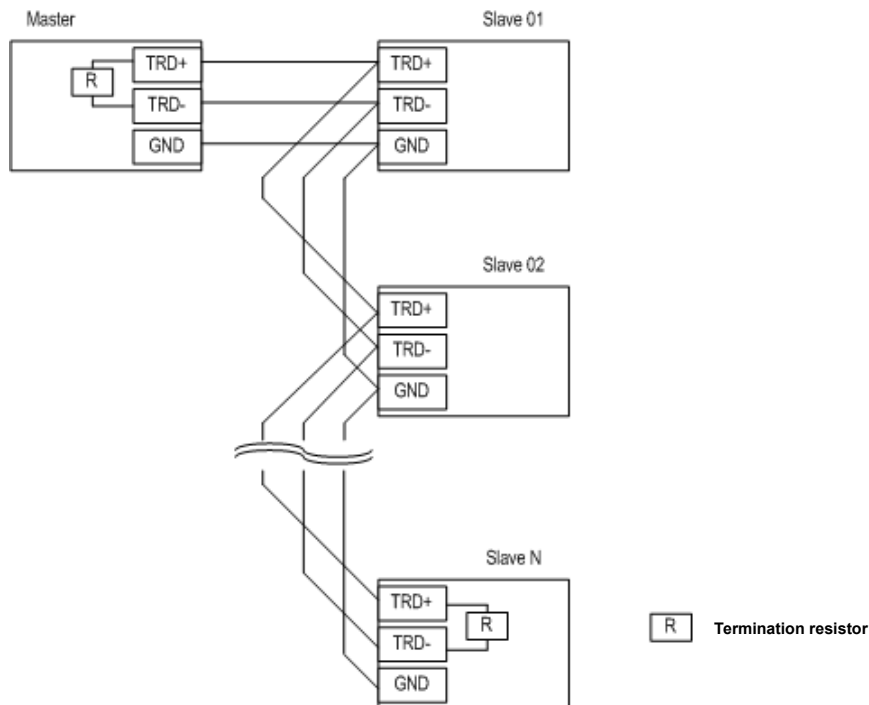

Fig. 3-2-7 Sample connection

3. Configuration for MODBUS communication

To configure MODBUS communications:

- open "Advanced setting" in upper line
- Select 8. "Digital out" in left menu box.

Baud rate and Parity must be set to match the master device. Slave address must not be overlapped with another device.

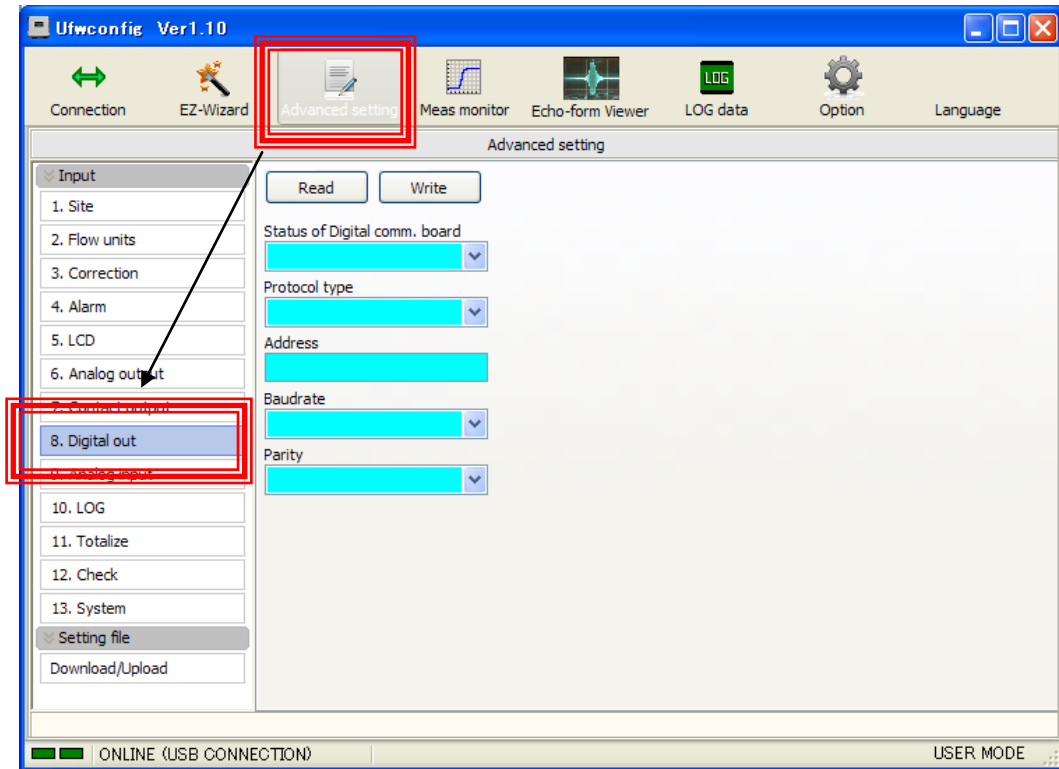

4. Supported function codes

Supported function codes are listed in table 4 below.

Table 4 Function Codes

Function Code	Name	Supported
03h	Read Holding Register	Yes
04h	Read Input Register	Yes
10h (*1)	Preset Multiple Registers	Yes

(*1) Function Code 10h (Preset Multiple Registers) must be changed individually (parameter by parameter). Do not change multiple parameters at once! After changing a register value, reconfirmation of revised value by utilizing Function code 04h is recommended.

5. Registers

5.1 Input Register

Table 5.1 INPUT REGISTER ADDRESS - Read Function code [04h]

Reg No.	Type	Parameter	Description
30001	long	Forward totalized value	Range 00000000 to 99999999
30002			Selected unit will be used
30003	long	Backward totalized value	Range 00000000 to 99999999
30004			Selected unit will be used
30005	float	Flow rate	Selected unit will be used
30006			
30007	float	Flow velocity	Unit: Metric [m/s], English [ft/s]
30008			
30009	float	Analog input value	Unit: [%] or [mA]
30010			Selected unit will be used
30011	short	Status code	Bit11 B.D. Bit10 LB Bit09 CHECK Bit08 H-LIMIT Bit07 L-LIMIT Bit06 FW Bit05 F.S. Bit04 - Bit03 SAT Bit02 DIS. Bit01 ROFF Bit00 roff
30012	short	Error code	Bit05 PRM Bit04 EEP Bit03 RTC Bit02 DSP Bit01 CPU Bit00 TRX
30013	short	ROFF history(Q'ty)	0 to 9999
30014	short	DIS. history(Q'ty)	0 to 9999
30015	float	Upside Gain Amplitude	0 to 100 [%]
30016			
30017	float	Downside Gain Amplitude	0 to 100 [%]
30018			
30019	short	GAIN U(LO/Hi)	(0)Lo, (1)Hi
30020	short	GAIN D(LO/Hi)	(0)Lo, (1)Hi
30021	float	Analog output current	Unit: mA
30022			
30023	short	Main unit temp.	Unit: [deg C]
30024	-	-	-
30025	long	ID No.	
30026			
30027	short	Year	Internal year
30028	short	Month	Internal month
30029	short	Day	Internal date
30030	short	Hour	Internal hour

30031	short	Minutes	Internal minute
30032	short	Second	internal second
30033	short	System Unit	(0)Metric, (1)English
30034	short	Flow decimal point position	(0)*****, (1)****.*, (2)****.**, (3)***.***, (4)**.****
30035	short	Flow multiplier	(0)u, (1)m, (2)x1, (3)k, (4)M
30036	short	Flow volume units	(0)L, (1)m ³ , (2)g, (3)t, (4)ft ³ , (5)bbl, (6)gal, (7)acf
30037	short	Flow time units	(0)/sec, (1)/min, (2)/hour, (3)/Day
30038	short	Total decimal point position	(0)x1, (1)x0.1, (2)x0.01
30039	short	Total multiplier	(0)u, (1)m, (2)x1, (3)k, (4)M
30040	short	Total units	(0)L, (1)m ³ , (2)g, (3)t, (4)ft ³ , (5)bbl, (6)gal, (7)acf
30041	short	Analog Input format	(0)%, (1)mA
30042	-	reserve	reserve
to	-	reserve	reserve
30100	-	reserve	reserve

To download the logged data and wave-form data without using the configuration software, please consult the manufacturer.

5.2 Holding Register

Table 5.2 HOLDING REGISTER ADDRESS - Read Function code [03h] / Write Function code [10h]

Reg.No	Type	Parameter	Description
40001	long	Device code	Read only
40002			Value = 554657
to	-	-	Reserved. (Write-in inhibited.)
40020	-	-	Reserved. (Write-in inhibited.)

(1) Site data

40021	float	Outside diameter	Unit: Metric [mm], English [inch]
40022			
40023	short	Pipe material	(0)User-defined, (1)Steel, (2)Ductile iron (3)Cast iron, (4)Copper, (5)Stainless steel, (6)PVC, (7)FRP, (8)Acrylic
40024	-	-	-
40025	float	Pipe thickness	Unit: Metric [mm], English [inch]
40026			
40027	float	Pipe sound speed	Unit: Metric [m/s], English [ft/s] Use in case "User-defined" selected as Pipe material.
40028			
40029	short	Lining material	(0)User-defined, (1)None, (2)Epoxy, (3)Mortar, (4)Rubber, (5)PVC
40030	-	-	-
40031	float	Lining thickness	Unit: Metric [mm], English [inch]
40032			
40033	float	Lining sound speed	Unit: Metric [m/s], English [ft/s] Use in case "User-defined" selected as Lining material.
40034			
40035	short	Transducer type	(1)SE104720T
40036	-	-	-
40037	short	Installation method	(1)Z-PATH, (2)V-PATH
40038	-	-	-
40039	float	Cable length	Unit: Metric [m], English [ft]
40040			
40041	short	Fluid type	(0)User-defined, (1)Water, (2)Seawater
40042	-	-	-
40043	float	Fluid sound speed	Unit: Metric [m/s], English [ft/s] Use in case "User-defined" selected as Fluid type.
40044			
40045	float	Fluid viscosity	Unit: Metric [$\times 10^{-6}$ m ² /s], English [$\times 10^{-6}$ ft ² /s] Use in case "User-defined" selected as Fluid type.
40046			
40047	float	Fluid density	Unit: [kg/m ³] Use in case "User-defined" selected as Fluid type.
40048			
40049	-	-	-
40050	-	-	-
40051	float	F-DIST	Read Only Unit: Metric [mm], English [inch]
40052			
to	-	-	Reserved. (Write-in inhibited.)
40060	-	-	Reserved. (Write-in inhibited.)

(2) Flow unit

40061	short	Flow decimal point position	(0)*****, (1)****.*, (2)****.**, (3)***.***, (4)**.***, (5)*.****
40062	-	-	-
40063	short	Flow multiplier	(0)u (1)m (2)x1 (3)k (4)M
40064	-	-	-
40065	short	Flow volume units	(0)L/ (1)m ³ / (2)g/ (3)l/ (4)ft ³ / (5)bb/ (6)gal/ (7)acf/
40066	-	-	-
40067	short	Flow time units	(0)/sec (1)/min (2)/hour (3)/Day
40068	-	-	-
to	-	-	Reserved. (Write-in inhibited.)
40080	-	-	Reserved. (Write-in inhibited.)

(3) Correction

40081	float	Zero point correction	-99999 to 999999
40082			Unit: selected flow unit will be used
40083	float	Span correction	00.001 to 20.000
40084			
40085	float	Flow volume cutoff	0 to 999999
40086			Unit: selected flow unit will be used
40087	short	Output filter	0 to 120s
40088	-	-	-
to	-	-	Reserved. (Write-in inhibited.)
40100	-	-	Reserved. (Write-in inhibited.)

(4) Alarm

40101	short	B.D. operation	(0)HOLD, (1)0%, (2)100%, (3)BURN OUT
40102	-	-	-
40103	short	ROFF operation	(0)HOLD, (1)0%, (2)100%, (3)BURN OUT
40104	-	-	-
40105	short	Limit alarm	(0)OFF, (1)ON
40106	-	-	-
40107	float	Hi-Limit alarm value	-99999 to 999999
40108			Unit: selected flow unit will be used
40109	float	Lo-Limit alarm value	-99999 to 999999
40110			Unit: selected flow unit will be used
40111	float	Maximum gain	0 to 100%
40112			
to	-	-	Reserved. (Write-in inhibited.)
40130	-	-	Reserved. (Write-in inhibited.)

(5) LCD

40131	short	LCD page1 upper line	(0)FLOWRATE, (1)VELOCITY, (2)FW TOTAL, (3)BW TOTAL, (4)STATUS, (5)ANALOG-IN, (6)ROFF CNT, (7)DIS. CNT, (8)AGA U, (9)AGA D, (10)DATE, (11)TIME
40132	-	-	-
40133	short	LCD page1 lower line	same as "Reg.40131"
40134	-	-	-
40135	short	LCD page2 upper line	same as "Reg.40131"
40136	-	-	-

40137	short	LCD page2 lower line	same as "Reg.40131"
40138	-	-	-
40139	short	LCD page3 upper line	same as "Reg.40131"
40140	-	-	-
40141	short	LCD page3 lower line	same as "Reg.40131"
40142	-	-	-
40143	short	LCD page4 upper line	same as "Reg.40131"
40144	-	-	-
40145	short	LCD page4 lower line	same as "Reg.40131"
40146	-	-	-
40147	short	LCD page5 upper line	same as "Reg.40131"
40148	-	-	-
40149	short	LCD page5 lower line	same as "Reg.40131"
40150	-	-	-
40151	short	LCD page6 upper line	same as "Reg.40131"
40152	-	-	-
40153	short	LCD page6 lower line	same as "Reg.40131"
40154	-	-	-
to	-	-	Reserved. (Write-in inhibited.)
40170	-	-	Reserved. (Write-in inhibited.)

(6) Analog output

40171	float	20mA output Flowrate	-99999 to 999999
40172			Unit: Selected flow unit will be used
40173	float	4mA output Flowrate	-99999 to 999999
40174			Unit: Selected flow unit will be used
40175	short	Fit analog span	(0)OFF, (1)ON
40176	-	-	-
to	-	-	Reserved. (Write-in inhibited.)
40200	-	-	Reserved. (Write-in inhibited.)

(7) Contact output

40201	short	Contact output	(0)BREAK, (1)MAKE, (2)FW-PULSE, (3)BW-PULSE, (4)ROFF, (5)B.D., (6)B.D. OR ROFF, (7)H-LIMIT, (8)L-LIMIT, (9)FW-DIRECT
40202	-	-	-
40203	short	Logic inversion	(0)OFF, (1)ON
40204	-	-	-
40205	short	Totalized pulse width	(0)20ms, (1)100ms, (2)500ms, (3)1000ms
40206	-	-	-
to	-	-	Reserved. (Write-in inhibited.)
40220	-	-	Reserved. (Write-in inhibited.)

(8) Digital communication

40221	short	Status of Digital-communication board	Read Only (0)INVALID, (1)RS-485
40222	-	-	-
40223	short	Protocol type	(0)MODBUS-RTU
40224	-	-	-
40225	short	MODBUS Slave address	000 to 247
40226	-	-	-
40227	short	MODBUS Baud rate	(0)4800bps, (1)9600bps, (2)19200bps,

			(3)38400bps
40228	-	-	-
40229	short	MODBUS Parity	(0)None, (1)Odd, (2)Even
40230	-	-	-
to	-	-	Reserved. (Write-in inhibited.)
40250	-	-	Reserved. (Write-in inhibited.)

(9) Analog input

40251	short	Status of optional board	Read Only (0)INVALID, (1)AIN
40252	-	-	-
40253	short	Analog input format	(0)%, (1)mA
40254	-	-	-
to	-	-	Reserved. (Write-in inhibited.)
40280	-	-	Reserved. (Write-in inhibited.)

(10) LOG

40281	short	LOG data revision	Read Only
40282	-	-	-
40283	short	LOG interval	0 to 3600 s
40284	-	-	-
40285	short	LOG area initialize command	(0)No, (1)Yes
40286	-	-	-
to	-	-	Reserved. (Write-in inhibited.)
40310	-	-	Reserved. (Write-in inhibited.)

(11) Totalizing

40311	short	Total decimal point position	(0)***** [$\times 1$], (1)*****.* [$\times 0.1$], (2)*****.** [$\times 0.01$]
40312	-	-	-
40313	short	Total multiplier	(0)u 1E-6, (1)m 1E-3, (2)x1, (3)k 1E+3 (4)M 1E+6
40314	-	-	-
40315	short	Total units	(0)L, (1)m ³ , (2)g, (3)t, (4)ft ³ , (5)bbl, (6)gal, (7)acf
40316	-	-	-
40317	long	Forward preset value	00000000 to 99999999
40318			Unit: Selected unit will be used.
40319	long	Backward preset value	00000000 to 99999999
40320			Unit: Selected unit will be used.
40321	short	Preset command	(0)NO, (1)YES
40322	-	-	-
to	-	-	Reserved. (Write-in inhibited.)
40340	-	-	Reserved. (Write-in inhibited.)

(12) Check

40341	short	ROFF/DIS Clear command	(0)NO, (1)YES
40342	-	-	-
40343	short	Simulated flow check mode	(0)OFF, (1)ON
40344	-	-	-
40345	float	Simulated flow check value	Unit: selected flow unit will be used
40346			
40347	short	Analog out check mode	(0)OFF, (1)ON

40348	-	-	-
40349	float	Analog out check current	3.800 to 20.500 mA
40350			
40351	short	Contact pulse out check mode	(0)OFF, (1)ON
40352	-	-	-
40353	short	Number of output contact pulses	0 to 25 Hz
40354	-	-	-
40355	float	Firmware version	Read Only
40356			
40357	-	-	-
40358	-	-	-
40359	-	-	-
40360	-	-	-
40361	short	Restart command	(0)NO, (1)YES
40362	-	-	-
40363	short	Parameter initialize command	(0)NO, (1)YES
40364	-	-	-
to	-	-	Reserved. (Write-in inhibited.)
40430	-	-	Reserved. (Write-in inhibited.)

(13) System

40431	short	Parameter protection (For key operation)	(0)OFF, (1)ON
40432	-	-	-
40433	short	System units	(0)METRIC, (1)ENGLISH
40434	-	-	-
40435	short	Date format	(0)YYMMDD, (1)MMDDYY, (2)DDMMYY
40436	-	-	-
40437	short	Date separation	(0)/, (1)-, (2).
40438	-	-	-
40439	short	Year	0 to 99 (last 2 digit of CY2000 to CY2099)
40440	-	-	-
40441	short	Month	1 to 12
40442	-	-	-
40443	short	Date	1 to 31
40444	-	-	-
40445	short	Hour	0 to 23
40446	-	-	-
40447	short	minute	0 to 59
40448	-	-	-
40449	short	second	0 to 59
40450	-	-	-
40451	long	ID No.	00000 to 99999
40452			
to	-	-	Reserved. (Write-in inhibited.)
40470	-	-	Reserved. (Write-in inhibited.)

3-3. Principles of the Ultrasonic Flowmeter

3-3-1 Measurement principles

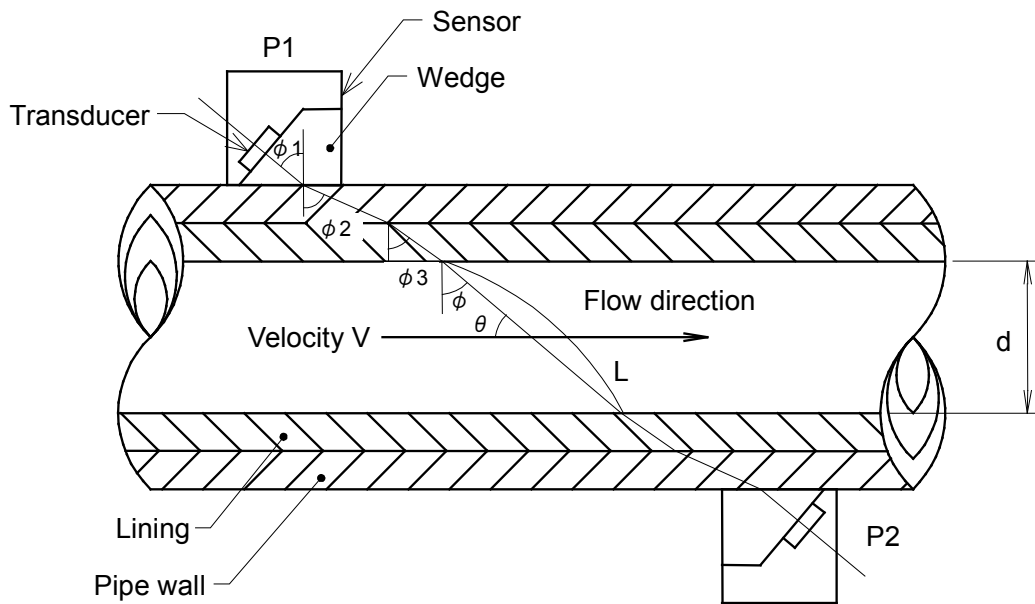

Fig. 3-3-1 Ultrasonic Wave Propagation Route

A sensor (called "Transducer") consists of a transducer for transmitting and receiving ultrasonic waves and a plastic wedge. Transducers P1 and P2 have the same structure and characteristics.

When an ultrasonic pulse is transmitted from the transducer of transducer P1, the pulse is propagated through the wedge and strikes the boundary with the pipe wall at angle $\phi 1$. The wave is then refracted and propagated through the pipe wall at angle $\phi 2$.

The pulse then passes through the lining at refraction angle $\phi 3$ and through the fluid at refraction angle ϕ .

When the velocity of sound is defined as $C1$ in the wedge, $C2$ in the pipe wall, $C3$ in the lining, and C in the fluid, the following formula can be deduced from the law of refraction.

$$\frac{\sin \phi 1}{C1} = \frac{\sin \phi 2}{C2} = \frac{\sin \phi 3}{C3} = \frac{\sin \phi}{C} \tag{1}$$

The ultrasonic pulse propagated through the fluid reverses the previous path (fluid → lining → pipe wall) and is received by transducer P2. The received pulse is then converted into an electronic pulse.

The following formula can be written when the propagation time of an ultrasonic pulse from P1 to P2 (in other words the positive direction of the fluid) is defined as td .

$$td = \frac{d}{\sin \theta \cdot (C + V \cdot \cos \theta)} + \tau \tag{2}$$

Conversely, the following formula can be written when the propagation time of an ultrasonic pulse from P2 to P1 (in other words the reverse direction of the fluid) is defined as tu.

$$tu = \frac{d}{\sin \theta \cdot (C - V \cdot \cos \theta)} + \tau \tag{3}$$

In these formulas d is the internal diameter of the pipe, θ is the angle between the ultrasonic pulse advance and the flow direction, and τ is the fixed delay time (sum of time required for the pulse to travel through the wedge, pipe wall, and lining and the electronic delay time of the flowmeter).

Since the velocity of sound in water C is much larger than flow rate V, the following assumption can be made: $C^2 > V^2 \cos^2 \theta$

Therefore, when the propagation time difference $\Delta t = tu - td$ is calculated, the following formula can be deduced from formulas (2) and (3).

$$\Delta t = tu - td = \frac{2 \cdot (d/\sin \theta) \cdot V \cdot \cos \theta}{C^2} \tag{4}$$

However, the velocity of sound C included in this formula will vary depending on the fluid temperature and other factors. Therefore, with this ultrasonic flowmeter, the velocity of sound C in water is cancelled out as shown below in order to eliminate its affect.

If the propagation time in still water is defined as to, formula (5) can be deduced from formulas (2) and (3).

$$to = \frac{tu + td}{2} = \frac{d/\sin \theta}{C} + \tau \tag{5}$$

The following is then obtained by substituting formula (4) into the above formula.

$$\Delta t = \frac{2 \cdot (to - \tau)^2 \cdot V \cdot \cos \theta}{d/\sin \theta} \tag{6}$$

Finally, the following is obtained by solving for V in formula (6).

$$V = \frac{d/\sin \theta}{2 \cdot (to - \tau)^2 \cdot \cos \theta} \cdot \Delta t = \frac{d}{2 \cdot \sin \theta \cdot \cos \theta \cdot (to - \tau)^2} \cdot \Delta t \tag{7}$$

Since the flow velocity V obtained by the ultrasonic flowmeter is an average velocity through the diameter between the transducers, the actual average velocity \bar{V} is different. The ratio between these 2 velocities is expressed using flow volume correction coefficient k, as shown below.

Flow volume correction coefficient (k)

$$= \frac{\text{Average flow velocity obtained by ultrasonic flowmeter } (V)}{\text{Actual average flow velocity } (\bar{V})} \quad (8)$$

Next, flow volume q can be expressed as shown in formula (9) when the cross sectional area of the pipe is defined as A .

$$q = A \cdot \bar{V} = A \cdot \frac{V}{k} = \frac{1}{k} \cdot \frac{\pi \cdot d^2}{4} \cdot \frac{d}{2 \cdot \sin \theta \cdot \cos \theta \cdot (t_o - \tau)^2} \cdot \Delta t$$

$$= \left[\frac{1}{k} \cdot \left\{ \frac{\pi \cdot d^2}{4} \cdot \frac{d}{2 \cdot \sin \theta \cdot \cos \theta} \right\} \right] \cdot \frac{\Delta t}{(t_o - \tau)^2} \quad (9)$$

Scale factor

Therefore, if the scale factor in formula (9) is calculated beforehand, flow volume q can be calculated from the actual measurement values of formulas (4) and (5). In other words, formula (9) shows that the affects of changes in the velocity of sound in water can be eliminated by measuring Δt and t_o .

Next, the flow volume correction coefficient k , expressing the relationship between the measurement velocity V and the actual average velocity \bar{V} as shown by formula (8), changes depending on the Reynolds Number. Therefore, with this ultrasonic flowmeter, the velocity V obtained from formula (7) using the ultrasonic flowmeter is further used to obtain a temporary average velocity \bar{V} using formula (10). The Reynolds Number Re expressed in formula (11) is then calculated using this temporary value.

$$\bar{V} = \frac{V}{1.05} \quad (10)$$

$$Re = \frac{d \cdot \bar{V}}{\nu} \quad (\nu; \text{Kinematic viscosity}) \quad (11)$$

Finally, the Reynolds Number Re calculated using formula (11) is used to calculate a flow volume correction coefficient k , correlated to the flow velocity, from the formula of G.E. Birger.

Since the above calculation processes are done by a microcomputer, accurate flow volume measurement is possible.

3-3-2 Transmission and reflection methods

With ultrasonic flowmeters, depending on the propagation route of the ultrasonic waves, the measurement methods can be divided into the transmission method (Z method) and the reflection method (V method) as shown in Fig. 3-2. Since the above explanation of measurement principles used the transmission method, the reflection method will be explained here. An advantage of the reflection method is the ability to consistently obtain correct measurement values even when some flowing components move perpendicular to the flow direction. These situations include circling flow, etc. However, since the propagation route of the ultrasonic waves is approximately twice the length of the route with the transmission method, larger propagation loss occurs.

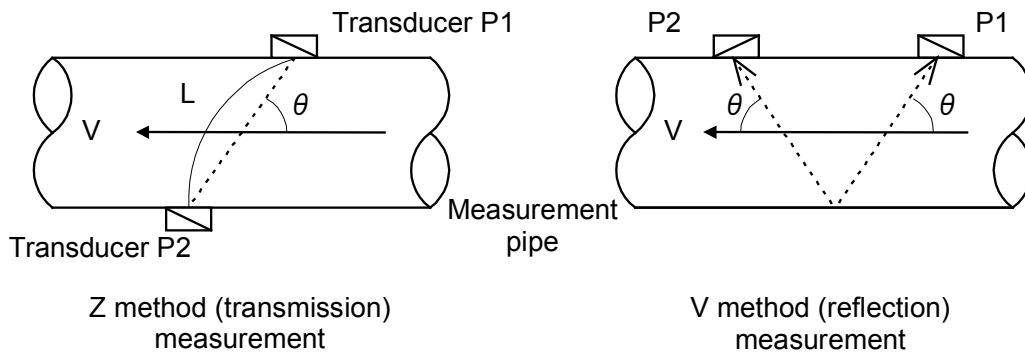

Fig. 3-3-2 Measurement Methods

With the reflection method, although the internal diameter is doubled, as shown in the figure below, the flow rate is the same and the calculation formulas of the transmission method are applicable. Therefore, d is changed to $2d$ and the scale factor is cut in half. Aside from such small changes, the same formulas are generally used.

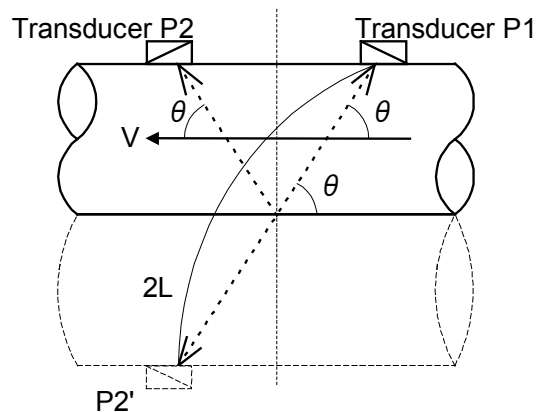
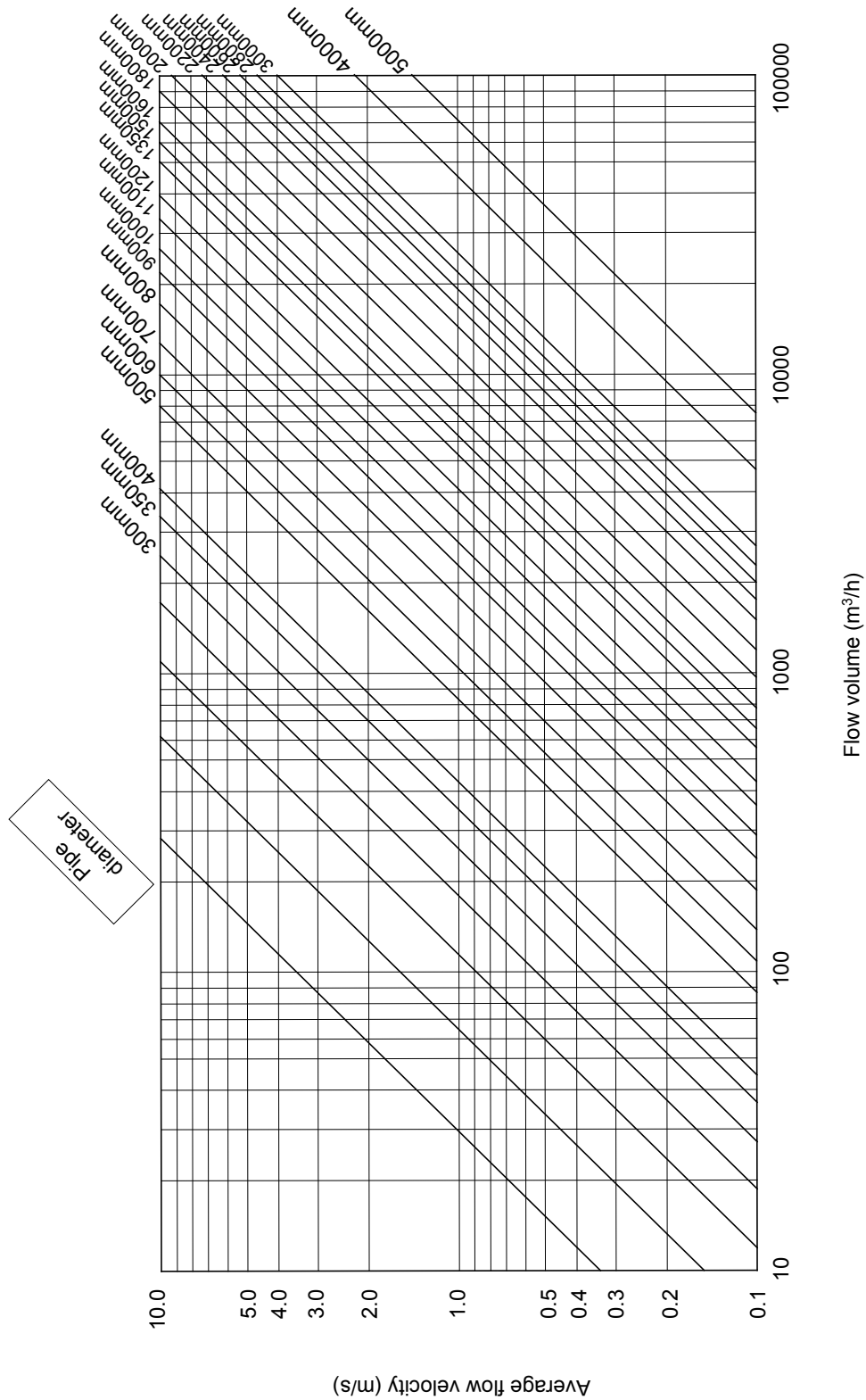

Fig. 3-3-3 Explanatory Diagram for Reflection Method

3-4 Appendix

3-4-1 Flow volume and average flow velocity



3-4-2 Pipe conditions and required straight pipe length

[Refer to JEMIS 032-1987.]

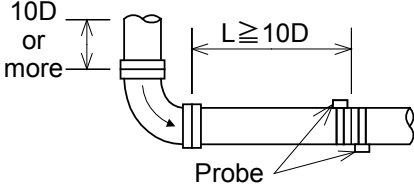
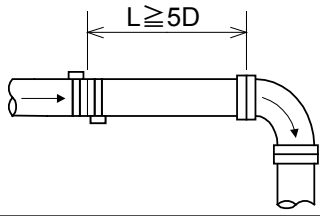
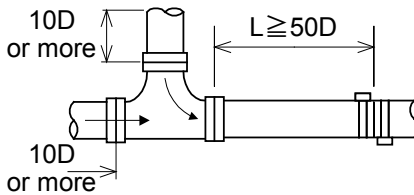
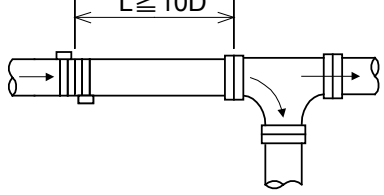
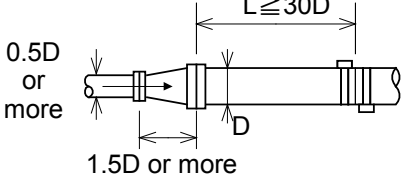
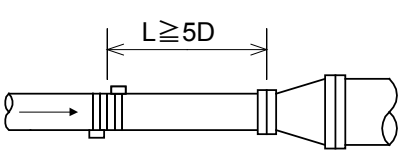
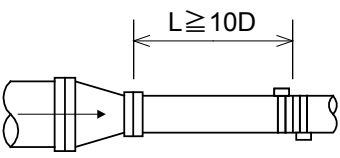
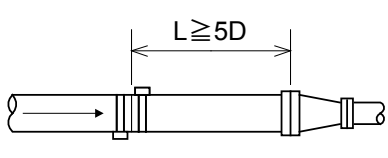
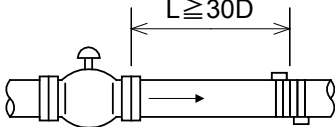
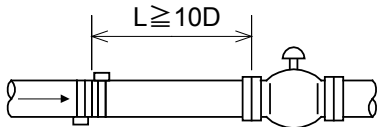
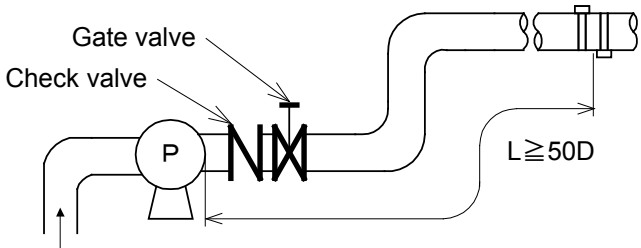
Section	Upstream straight pipe length	Downstream straight pipe length
90° bend		
T		
Expanding pipe		
Contracting pipe		
Various valves	 <p>When flow volume is adjusted at the upstream valve.</p>	 <p>When flow volume is adjusted at the downstream valve.</p>
Pump		

[D: pipe diameter]

3-4-3. Sound Velocity & Kinematic Viscosity reference list

Main unit uses following value for internal setting parameter, but those values are considered as nominal.

a. Pipe material reference

Material type	Material Name	Velocity (m/s)
Metal	Copper (*1)	2270
	Inconel	3020
	Ductile Iron (*1)	3000
	Cast Iron (*1)	2500
	Monel	2720
	Nickel	2960
	Carbon Steel (*1)	3200
	Stainless Steel (*1)	3100
	Tantalum	2900
	Titanium	3110
Plastic	Polycarbonate	2300
	PVC (*1)	2280
	Acrylic (*1)	2720
	FRP (*1)	2560

(*1)When pipe material is selected, above value of velocity will be used.

b. Lining material reference

Material type	Material Name	Velocity (m/s)
Lining	Epoxy (*2)	2000
	Mortar (*2)	2350
	Rubber (*2)	1900
	PVC (*2)	2280

(*2)When lining material is selected, above value of velocity will be used.

c. Fluid material reference

Material type	Material Name	Composition Formula	Density [g/cm ³]	Velocity [m/s]	Viscosity [$\times 10^{-6}$ m ² /s]	
Alcohol	Butyl		0.71	1270	3.695(25°C)	
	Butanol		0.81	1268(20°C)	3.239(25°C)	
	Ethanol	C ₂ H ₅ OH	0.79	1127(30°C)	1.39(25°C)	
	Ethylene Glycol	>99.5%	1.11	1689(20°C)	17.208(25°C)	
	Ethylene Glycol solution (50wt%)			1.066	1691(15°C)	4.13(15°C)
					1683(25°C)	
					1670(40°C)	
	Ethylene Glycol solution (25wt%)				1599(15°C)	
				1603(25°C)		
				1609(40°C)		
Methanol	CH ₃ OH	0.8	1090(30°C)	0.695(25°C)		
Oil	Diesel Oil			1250		
	Gasoline	C ₈ H ₁₈	0.717	1250	0.574(25°C)	
	Glycerin	C ₃ H ₈ O ₃	1.26	1920	757.1(25°C)	
	Gravity Fuel Oil AA		0.99	1490		
	Kerosene		0.81	1320	1.5(25°C)	
	Motor Oil	SAE 20	0.87	1740	5.6 ~ 9.3(100°C)	
	Motor Oil	SAE 30	0.88	1700	190(25°C)	
	Baby Oil			1416(23°C)		
	Mineral-Heavy		0.843	1460	140(15°C)	
	Mineral-Light		0.825	1440	3(25°C)	
	Phenylated Silicone		1.1	1370		
	Silicone 1000 cSt		0.972	990	1000	
	Silicone 100 cSt		0.968	980	100	
	Silicone 10 cSt		0.94	968	10	
	Silicone 1 cSt		0.818	960	1	
	Olive Oil			1449(23°C)	100(25°C)	
	Lubricant	Mobil		1417(20°C)	31.5(40°C)	
	Paraffin Oil			1428(20°C)		
Solvent	Acetone		0.791	1158	0.399(25°C)	
	Benzene	C ₆ H ₆	0.88	1310(25°C)	0.711(25°C)	
	Chloro Benzene	C ₆ H ₅ Cl	1.11	1300(22°C)	0.722(25°C)	
	Toluene			1420		
Water	Water (*3)		1	1460(13.5°C)	1.2	
	Water		1	1550(60°C)	0.475	
	Sea Water (*3)		1.0231	1510	1 (25°C)	

(*3)When fluid type is selected, above value of velocity will be used.

3-5. FAQ

3-5-1. Measurement method

1.1 What is ultrasound?

Ultrasound refers to acoustic waves or vibrations of a frequency beyond the range of human hearing (generally above 20,000 Hz).

1.2 At what frequencies do ultrasonic flowmeters operate?

The frequency generally utilized is several 100kHz up to several MHz.

1.3 Why are such high frequencies used?

Frequencies in the normal range (i.e. in the audible range) are apt to mix with and become lost in the ambient noise.

1.4 Is ultrasound harmful to humans or animals?

No. Ultrasound is used in the medical field.

1.5 How does ultrasound measure flow?

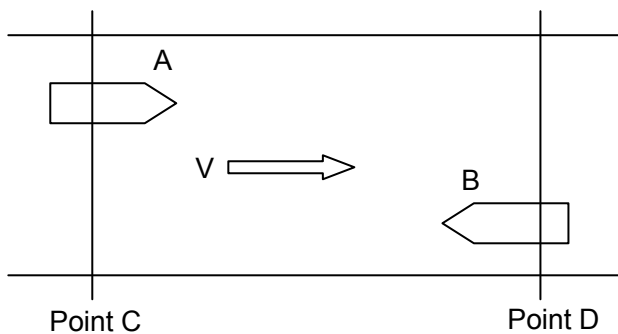

Fig. 3-5

Let us illustrate this by an example of two boats, 'A' and 'B', positioned at two points on a river as shown in Fig. 9. If boats 'A' and 'B' approach each other at exactly the same speed, the time, '**t_A**', it takes for boat 'A' to arrive at point 'D' and the time, '**t_B**', it takes for boat 'B' to arrive at point 'C' will be the same.

Now what would happen if the river is flowing at velocity '**V**' in the direction of the arrow as shown? What happens is that boat 'A' which is proceeding downstream will arrive at point 'D' faster than boat 'B' which is traveling upstream. In other words, time '**t_B**' is longer in comparison to time '**t_A**' which reflects the additional time involved in opposing the flow, and thus time, '**t_A**' for boat 'A' which is traveling downstream to arrive at point 'D' will be faster. This time difference is proportional to the magnitude of the velocity of the flow and this principle is utilized to measure flow velocities. This can be expressed by the formula:

$$t_B - t_A = \Delta t$$

where **Δt** is the time difference. This time difference can be calculated precisely with a clock pulse generated by a microcomputer to accurately measure flow.

As flow velocity '**V**' can be determined by measuring **Δt**, you can calculate the volume of flow

through a pipe or open channel by multiplying Δt by the cross sectional area of the pipe or open channel. In such calculations, it is necessary to employ a flow volume compensation coefficient with the measured flow velocity ' V ' in order to obtain average flow velocity.

1.6 Is the time difference method the only method used in ultrasonic flow measurement?

Presently there are three measurement methods in practical use.

- (1) Frequency difference method
- (2) Time difference method
- (3) Doppler method

Methods (1) and (2) are mainly used for measurement of relatively clean water. This is because fluctuations in propagation level of ultrasonic signals (i.e. sensitivity of ultrasonic transmissions and reception) become problematic with dirty water which reduces signal strength.

Measurement method (3) involves detection of frequency shifts (changes) in acoustic signals. As changes in signal propagation level is not directly a factor, this method is suitable for measurement of dirty water such as sewage.

1.7 Does acoustic velocity vary with water temperature?

Yes therefore, it is important to devise means to overcome the effect of acoustic velocity changes caused by changes in water temperature.

3-5-2. Measured fluids

2.1 Measured fluids

In principle, any liquid, which allows stable propagation of ultrasonic waves, can be measured. However in liquids where large amounts of air bubbles or solid particles are present, problems such as mis-measurements or non-measurable conditions may occur. As high temperature and high pressure liquids (oil, etc.) cannot be described categorically, consult manufacturer or local representative when measuring such liquids.

2.2 Can raw water be measured?

River water and raw water can be measured in addition to clean water.

2.3 In the case of raw water, how does turbidity affect measurement?

Two separate questions arise with regard to this.

- (1) Do changes in turbidity produce measurement error?
- (2) Does high turbidity attenuate acoustic signals creating non-measurable conditions?

Regarding (1), if the penetration of acoustic signals is adequate, changes in turbidity does not normally cause errors.

Regarding (2), although related to attenuation of acoustic signals by solid particles in the liquid, exceedingly high levels of turbidity does cause reduction in signal. TOSHIBA International Corporation specifies turbidity levels up to 10,000 in the case of a pipe diameter of 1m. (Note: turbidity of 1g of refined Kaolin clay in 1 liter of water is 1,000.)

Turbidity of 5,000 is quite severe, but as turbidity of river water rarely exceeds 1,000, there should be no problem for all practical purposes.

2.4 How is measurement affected if air enters the pipe?

- (1) Compared to water, air is a very difficult medium for the transmission of acoustic signals. Therefore when pumps continuously draw air into the piping, air bubbles will pass through the acoustic signal transverse path resulting in measurement swings or mis-measurements.
- (2) Also in cases where the depth of the tap from the water surface to the top of the pipe at the intake location is insufficient, air will be sucked into the pipe and may cause mis-measurements or create non-measurable conditions.
- (3) If air accumulates at the upper part of the pipe, although flow measurement can be carried out, the flow indicated will be larger than the actual flow. (Note: If the sensors are located vertically on the pipe, measurement cannot be done if there is a layer of air in the pipe.) Thus, in cases where there may be accumulation of air in pipes, air bleed valves should be installed fore and aft of the measurement position.

2.5 Can waste water be measured?

From the standpoint of turbidity, there are no problems with measuring waste water inflows or discharges. However pipe conditions in selecting measurement location should be carefully considered as air bubbles are apt to be generated when there are drops or when measuring locations are directly aft of pump discharge outlets.

2.6 Can measurements be made if solid particles or debris are present in the fluid?

The beam width (radiating width) of acoustic waves is sufficient to enable stable measurement in the presence of small-sized solid particles in the fluid. In the case of large size debris which can obstruct acoustic signals, the flowmeter has a discrimination function which can differentiate such conditions from normal measurement values and ignore such data input. However when there is continuous flow of fluid containing large volume of solid particles and debris, problems such as mis-measurements or non-measurable conditions are apt to occur.

3-5-3. Pipes

3.1 What kind of pipe material enables ultrasonic measurement?

We have had numerous experiences with measurements through steel, stainless steel, cast iron, ductile iron, and resins.

(1) Although we have measured through RC steel pipes, transmission of acoustic signals is difficult and this type of pipe material is not conducive to ultrasonic measurement.

(2) Measurement through pipes of asbestos material is possible on rare occasions, but for all practical purposes, measurement is not possible with this material.

(3) Hume pipes cannot be measured with sensors mounted on the outside of the pipe. Special measurement methods incorporating sensors on the inside of the pipe are employed for this type of application.

(4)The ultrasonic might not be propagated easily PVC lining steel pipe. Refer to 3.3.

(5)The ultrasonic might not be propagated easily into the Zinc-coated-pipe.

3.2 What are the minimum and maximum measurable pipe sizes?

Measurable diameters are from DN25mm to DN600mm.

3.3 Is pipe lining a problem?

Mortar, epoxy and other common linings on the inside of pipes do not affect measurement. In cases where the outside of pipes are wound with jute or similar material, remove this material at the location where the sensors are to be positioned.

PVC lined steel pipe is a type of pipe that may contain an air layer between metal and PVC lining partially due to how it was manufactured.

If this is the case, locate a better place for the ultrasonic location.

3.4 Are there problems with lining detachment from the pipe interior?

Centrifugal force is generally used to bond linings to the interior of pipes. Also during operation the pressure of the water also acts on the lining, so problems with lining detachments are few. Should such a problem occur however, as long as the sensors are not positioned directly at that point, there should be no adverse effect on measurements. Even if a slight separation of lining occurs at the point of measurement but not a complete detachment from the pipe wall, water would fill the space between the lining and the wall, and any deviations may be corrected for by readjusting the sensitivity of the system. Although not a sure method, a system readjustment or change in transducer position may enable measurement even in the case of lining separation.

3.5 How does rust or rust scale on the pipe interior affect measurement?

Rust spots in some places in cast iron pipes do not affect measurement. However, extensive rust on entire surfaces may cause errors or mis-measurements. For example, a 1mm accumulation of rust scale on the entire interior surface of the pipe of $\varnothing 1,000\text{mm}$ will result in a measurement error of approx. 0.7%.

3-5-4. Installation location

4.1 What straight length of pipe is necessary?

The Ultrasonic flowmeter requires "fully developed and rotationally symmetrical flow profile" as pre-condition.

The general upstream straight pipe length necessary for ultrasonic measurement to achieve fully developed and rotating symmetrically is more than 10D ('D' being the upstream pipe diameter), and more than 5D downstream in order to ensure measurement accuracy.

Please reference Chapter 3-4-2 'Pipe conditions and required straight pipe length'.

4.2 What is the affect on measurement if it rains?

The standard transducers are of waterproof construction IP65 conforming to IEC60529.

4.3 How far apart can the flowmeter unit and transducers be placed?

Coaxial cable is used to connect the main flowmeter electronic unit to the transducers. Coaxial cable length is limited to 30m. However, installation should also take into consideration external noise interference.

4.4 Why is a special trough needed for laying of coaxial cable?

Receiving signals of the sensors are very weak electrical signals and as such are susceptible to interference from other equipment. In addition to signal interference from power supply lines and output signal lines, interference via coaxial cables is a principal cause of problems. Main causes of signal interference include the following.

(1) High current lines which emit noise pulsations. Examples are power transmission lines which open and close valves which run parallel to the coaxial cables.

(2) Broadcasting signals are normally not a problem, but if the cables are located directly below such stations, for example, noise interference may result.

(3) AC equipment (motors), etc. are normally not a problem, but as described above, there may be interference caused during the opening and closing of circuits

(4) Rectifier equipment, etc., may also cause problems. (The flowmeter itself should not be located near a rectifier.)

4.5 Can the coaxial cables be suspended in the air?

Compared to buried cable, suspended cable is more susceptible to exogenous noise. As such installation also exposes the cable to lightning and thunder, coaxial cables should not be suspended aurally.

4.6 What are the recommended installation locations for the main flowmeter electronics unit?

The main flowmeter unit should be located where humidity is minimum and where it is not exposed to corrosive gases such as chloride or to direct sunlight. An air conditioned room is ideal, but please select a site which falls within a basic air temperature range of -10 to +60°C.

If the flowmeter is to be located on site, it should be placed in a chamber, pit or enclosure. Environmental conditions should be taken into consideration with measures such as interior enclosure insulation and installation of a ventilation fan as necessary.

Equipment is NOT EXPLOSION PROOF, so the flowmeter must not be located in an explosive environment.

4.7 What are 'Z' and 'V' methods of measurement?

These refer to transducer placements. The Z (through-transmission or single-traverse) method is where the transducers are mounted diametrically opposite each other and the ultrasonic signal is transmitted directly from one transducer to the other across the pipe. This method is used when the pipe is of adequate diameter or for pipes where acoustic signals are greatly reduced.

With the V (reflection or double traverse) method transducers are mounted on the same side of the pipe and the ultrasonic signal is bounced from one transducer to the other off the opposite pipe wall. This method is devised to measure flows that are not linear with the pipe axis and which are not affected by radial flow velocity components. The applicable diameters for the V method depends on pipe material but is generally less than $\varnothing 2,000\text{mm}$.

See Chapter 3-3-2 for more detail on the through transmission and reflection methods.

3-5-5. Other

5.1 What is the foremost advantage of ultrasonic flow measurement over other types of flow measurement?

- (1) The equipment can be installed on existing pipes without interrupting flow and as such is ideal in applications involving facilities management.
- (2) Transducers are non-intrusive and do not obstruct flow or cause head losses.
- (3) There is no great cost difference relative to pipe size diameter so compared to other types of measurement, it is comparatively low cost when large diameter pipes are involved.

5.2 Can the equipment be linked to telemeters or higher order computer systems?

As unified DC 4 - 20mA output signals for momentary flow are provided, the equipment can be linked with other types of measurement equipment. Also the exchange of totalized flow data can be accomplished through relay pulses. If RS-485 output is desired, you can specify an optional Board. In addition, USB communication output is also provided.

5.3 Does maintenance involve a lot of work?

As the hardware does not employ any moving parts, there is no need for lubrication, scouring, or mechanical adjustments. Electronic circuits include long life solid state CPU's and IC's which do not require daily maintenance. See Chapter 3-1 'Maintenance and Inspections'.

5.4 Even with pipe diameter and flow volume information, isn't the calculation of flow velocity cumbersome?

Determining cross sectional area from the diameter of the pipe, and dividing flow volume by the cross sectional area to calculate flow velocity may be a bit troublesome. This task can be aided by the graph in Chapter 3-4-1, 'Flow volume and Average Flow Velocity'. The vertical axis of the graph is the average flow velocity, the horizontal axis - the flow volume, and the diagonal lines represent various pipe diameters. As an example, for a pipe diameter of $\varnothing 600\text{mm}$, find the applicable diagonal. If the flow volume is $1,000 \text{ m}^3/\text{h}$, proceed up from the horizontal scale at $1,000 \text{ m}^3/\text{h}$, until you intersect the $\varnothing 600\text{m}$ diagonal and then angle 90° to the left to the corresponding point on the vertical scale to determine flow velocity. In this case, flow velocity will be 1m/s . For full scale flow, operating flow, and minimum flow volumes, it is simpler to consider these in terms of flow velocity and use of the graph in Chapter 3-4-1, 'Flow Volume and Average Flow Velocity' is recommended.

3-6. Troubleshooting

3-6-1. Main flowmeter (electronics) unit and components

In the event of problems, please review this section to identify causes and suggested remedies.

If the steps shown in this section do not solve the problem, contact with the nearest representative.

- Unit does not start-up when the system is powered up.
 - Is the main circuit breaker activated?
 - Is the fuse burned out?
- LCD display is dim.
 - Was contrast adjusted? (See Chapter 2-1-2, "Contrast adjustment")
 - Has the specification life been exceeded?

NOTE
When key operation is not performed for certain period of time, display goes out for 1 second every 2.5 minutes cycle time for refresh purpose.

- Setting cannot be done by PC (no communication).
 - Is USB cable connected?
 - Is the driver for USB connection installed? (See Chapter 1-2-12)
 - Is the correct PC port selected?

If the above are not the causes, follow the steps below.

- Disconnect the USB cable and re-connect.
- Use another communication port on PC.
- Totalized value disappears when power is shut down.
 - Is backup battery dead? (Does "B" mark appear?)
- Flow values do not vary.
 - Does "R", "D" or "E" marks appear? (Values are held)
- Analog output does not vary.
 - Is analog check mode activated? (Is "C" displayed?)
- Contact output does not operate.
 - Was contact output allotted?
(Set Chapter 2-3-7 "Contact output")
- Circuit breaker actuates when power is turned on.
 - Does power exceed circuit breaker rating?
(See Chapter 3-2-2 "Main Unit Specifications, Rush Current")

3-6-2. Measurement

The following is a description of some general problems and remedies relating to measurement.

If the steps shown in this section do not solve the problem, contact TOSHIBA International Corporation.

(1) Pipes which cannot be measured

- Asbestos
 - If the pipe surface is sufficiently wet, measurements can be made in some cases, but generally it is difficult with this pipe material.

- FRPM
Ultrasonic may be attenuated through composite material; therefore, it is difficult to measure with this pipe material.
- Scale and rust
Pronounced scaling and rust inside of pipes causes attenuation and diffusion of acoustic signals and the drop in transmission and receiving sensitivity sometimes makes measurement impossible. Zinc coated pipe may be typical pipe conducive to scale and rust inside the pipe.

In these cases, a better measurement location (for example an area where there is little rust) might be found by shifting sensor positions which should improve signal reception.

Signal strength can be improved by the following option:

- V-path method to Z-path method

Care should be exercised when doing this because a narrower flow cross sectional area may output results which are not true flow values.

- PVC lining steel pipe
PVC lined steel pipe is a type of pipe that may contain an air layer between metal and PVC lining partially due to how it was manufactured.
it is best to find another point If this is the case, locate a better place for the ultrasonic location.
Also it would be better to improve signal strength by following option.
- V-path method to Z-path method
In this case, you may have same failure as chap. (5). Please refer to it.

(2) Fluids which cannot be measured

- The presence of continuous and large amounts of bubbles in the fluid will greatly attenuate the acoustic signal, cause missed measurements, or make measurement impossible.
Even ultrasonic flowmeters employing the Doppler method which works better under such entrained bubble conditions (compared to transit-time flowmeters), also encounter missed measurements or are unable to make measurements when there is a continuous and large amount of bubbles contained in the fluid being measured.
 - If the cause of bubbles is a drop in level upstream, lessen the drop.
 - When there is a layer of air in the pipe, install an air bleed valve forward of the measurement location.
 - Select measurement location where fluid contains few bubbles.

(3) Given measurement accuracy cannot be obtained

- Incorrect site condition
Check pipe specification.
- Insufficient straight pipe length
Required straight pipe length may vary according to changes in pipe conditions forward and backward of the measurement position (merged or separating flows, presence of valve, etc.).
- Inside pipe condition
Cause may also be attributable to changes in fluid cross sectional area due to pipe rust, scale and partially filled pipe conditions.
- Seam part of pipe
It may cause seam part to make un-expected reflection of ultrasonic. Select no-seam part for transducer installation.

(4) Measurement values are unstable

- Entrained bubbles or solid particles in the fluid

It may cause fluctuation or spikes in measurements or create non-measurable conditions. Please eliminate the sources of these problems.

- Cavitation occurs.

Cavitation sometimes occurs when butterfly valves are used.

When there is cavitation from entrained air, select a measurement position sufficiently distanced from such locations and where the bubble problem ceases to exist.

- External noise

Electrical signals received by ultrasonic flowmeters generally are very weak - in the order of a few mV's - and as such ultrasonic flowmeters are susceptible to power surges and noises.

When there is the possibility of external noise interference on ultrasonic flowmeter measurement, check the layout of each cable. In the case of noise intrusion (especially on sensor cables) from an AC power source, installation of a shielded transformer, etc., is effective. However, the high magnitude of noise interference from inverters sometimes invalidates such countermeasures.

• Avoid using long extension cables as they can add to the noise influence.

(5) Echo is received, but no fluid inside.

In some cases, the conditions relating to the pipe material, pipe diameter, or the transducer installation method, the ultrasonic may transmit on the pipe surface. When the location of the surface echo appears very near a proper echo point, the main unit may not be able to discriminate between the proper echo and the surface echo. Therefore, the unit may not be able to recognize the condition of the 'no echo received'.

When the transducer installation method is changed, it could be possible to avoid this problem.

A similar phenomenon might be shown in PVC lining steel pipe which may contain an air layer between metal and lining, even if there is a fluid. Refer to "**(1) Pipes which cannot be measured**".

Nomally gain will be set automatically to be 0~100% by "Auto Gain Control (AGC)" function. In case of manual setting, Maximum gain can be limited by "4-4 MAXGAIN" in the chapter of Alarm operation (Page ???). By setting the function "MAXGAIN", the problem of surface echo with no fluid inside of pipe may be avoided. The AGC gain value should be written down when the surface echo with no fluid inside reaches 50% level on the Echo-form Viewer. The MAXGAIN should be set to a value less than the value that you recorded above.

TOSHIBA INTERNATIONAL CORPORATION
