

TOSHIBA

6F8C0926

Integrated Controller **V** series

model 2000 Sequence Controller
S2T User's Manual — Basic Hardware —

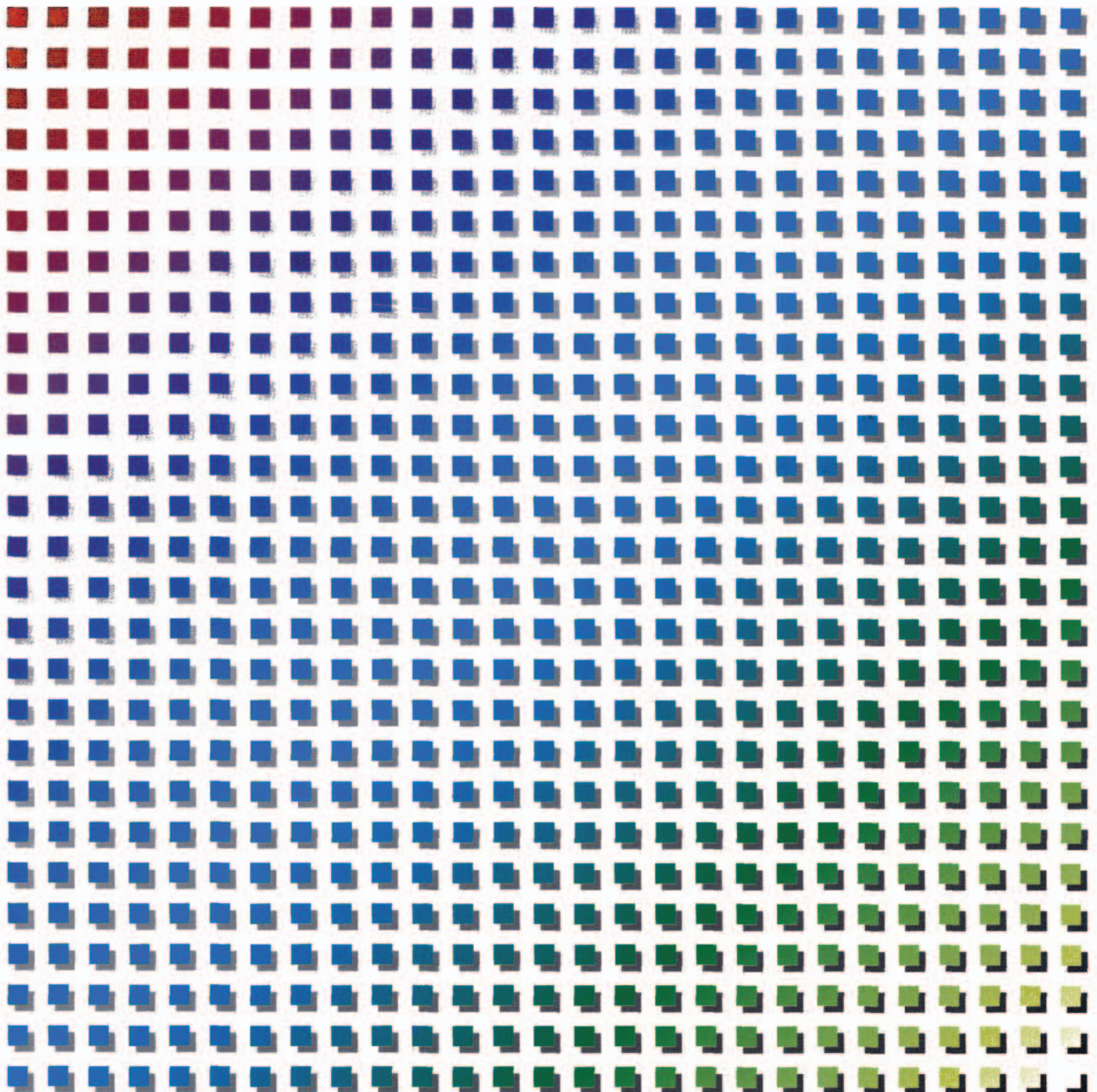



Safety Precautions

This manual contains important information for the operator to operate this product safely and correctly and avoid bodily injury and property damage.

Grasp the meanings of the following marks and their descriptions before reading this manual.

● Hazard Classifications



 WARNING	Indicates a potentially hazardous situation which, if not avoided, could result in serious injury or death.
 CAUTION	Indicates a potentially hazardous situation which, if not avoided, can result in minor or moderate injury, or property damage. It can also be used to alert against unsafe practices.

(Note) 1. Serious injury means loss of sight, injury, burns (high temperature, low temperature), electrical shock, fracture, or intoxication which leaves aftereffects or requires hospitalization or need to go the hospital for a long time.

2. Injury means hurt, burn, or electric shock which does not require hospitalization or going to the hospital for a long time.

3. Property damage means extended breakdown of assets and materials.

● Notation of Markings

	Indicates a "may not" mark. The concrete forbiddance is indicated with a pictograph or wording.
	Indicate a mandatory action that you should never fail to do. The concrete content is indicated inside or near the circle with a pictograph or wording.
	Indicates a caution. The concrete content is indicated inside or near the triangle.

(Note) The descriptions of forbiddance, mandatory, and caution marks are subject to change, depending on the labels on the main unit.

1. Markings used on the model 2000 and in this Manual

Make sure warning markings are attached on the model 2000.

If any of them are missing or the wording is illegible, contact Toshiba's Service Department.

[Warning Mark on the model 2000]



This is the warning mark for dangerous location. It is attached to the equipment at positions where there is a risk of electric shock and at positions where there is a risk of damage to the equipment through incorrect wiring.

Take the following precautions where this mark is found.

- (1) Keep hands away from terminals, especially the input terminal of the power supply while power is on, to avoid the risk of electric shock.
- (2) Turn off power before installing or removing modules, terminal blocks, or wires.
- (3) Applying excess power voltage to the model 2000 can cause failure or malfunction. Apply power of the specified ratings described in this manual.
- (4) Turn off the power of the tool (a personal computer, etc.) before connecting the connector to the tool port. Afterwards, turn on power.
Avoid short-circuiting between the tool connector pins with the cover, etc.

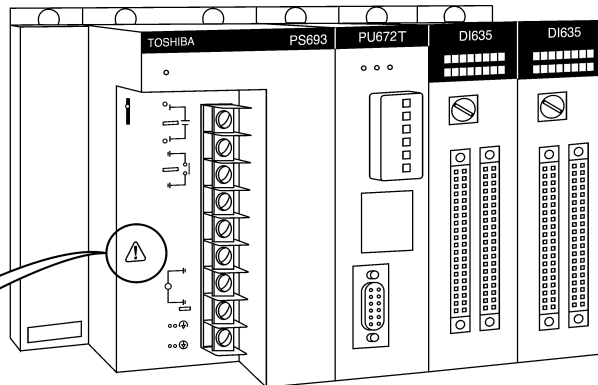

[Safety Label]



The safety label as shown on the left both in Japanese and English is attached to the power supply terminal of the model 2000. (except the 24Vdc input power supply module)

Remove the mount paper before wiring

Peel off either of the Japanese and English labels from the mount paper and stick it to the model 2000 or near the power terminal where it can be readily seen.

In the event the seal is damaged, contact the dealer.

NOTE

Marks printed at pages in this manual should always be read carefully.
Be sure to read them in handling your model 2000.

2. Precautions on Installation

WARNING



Mandatory

Be sure to ground the model 2000. The protective ground terminal of the model 2000 must be connected to an external protective earth.

Operation without grounding may cause accidental fire or shock.

CAUTION



Mandatory

Avoid the following locations when installing or storing the model 2000.

- Locations where there is dust, salinity or ion particles
- Locations where there are corrosive gases (SO₂, H₂S) or flammable gases
- Locations where vibration or shock occurs beyond the allowance
- Locations where there is condensation due to sharp temperature variations
- Locations where the ambient temperature exceeds the allowance range
- Locations where the relative humidity exceeds the allowance range
- Locations where the model 2000 is exposed to direct sunlight
- Locations where strong electric radiation or magnetic field is generated



Mandatory

Install the model 2000 at a place where maintenance and inspection are easy to do. Otherwise, recovery from failure may take much more time, leading to a serious accidents.



Forbidden

Do not cover the hole of the model 2000, and the ventilator/air inlet of the system. Otherwise, overheating, etc. can cause fire or malfunction.



Mandatory

Improper the installation or wiring of the system can cause not only insufficient performance but also malfunction and failure of the model 2000.

Installation in an unspecified direction or improper installation can cause fall-off, fire, interference, or malfunction of the model 2000.



Mandatory

Avoid entering wire scraps or other foreign debris into the model 2000, and related equipment. Otherwise, it can cause fire, failure or malfunction.

3. Precautions on Wiring

WARNING



Mandatory

Be sure to turn off power before wiring. Otherwise, it can cause electric shock or malfunction of the model 2000.



Mandatory

Be sure to use crimp-style terminal with insulating sheath or insulating tape to cover the conductive parts when wiring modules so that no conductive parts are exposed. Handle the terminal cover with care so as not to fall off or get damaged. Be sure to fix the cover on the terminal block after wiring. An exposed conductive part can cause electrical shock.

CAUTION



Mandatory

Apply power of the specified ratings described in the manual. Applying excess power voltage to the model 2000 can cause explosion or fire.



Mandatory

It is assumed that the users have general knowledge of industrial electrical control systems.

4. Precautions for Operation

WARNING



Mandatory

Configure emergency stop interlocking circuit outside the model 2000. Otherwise, failure and malfunction of the model 2000 can cause human injury, machine damage or serious accidents.



Mandatory

Be sure to keep the terminal block covers closed during power ON. Do not touch the terminals. Otherwise, it can cause electrical shock or injury.

CAUTION



Forbidden

The power supply modules, the CPU modules, the direct I/O modules and the expansion interface are dedicated to the model 2000. Mount them on the bases of the model 2000. Do not use them by themselves for other purposes. Otherwise, it can cause electrical shock or injury or malfunction.



Mandatory

When you attempt to perform program change, forced output, RUN/HALT controls, etc during operation, carefully check for safety. Improper operation or negligence in checking safety conditions can cause machine damage or serious accidents.



Mandatory

Mount the modules on the base securely until they click, and fix them on the base with screws. Insufficient installation can cause failure or malfunction.



Mandatory

Set the operating switches of the model 2000 according to this manual. Improper setting can cause failure or malfunction.



Mandatory

Sample programs and circuits described in this manual are provided for explaining the operations and applications of the S2T. You should test completely before using them as a part of your application system.



Mandatory

Install fuses suited to the load current capacity in the external circuits for the relay output module, preventing from overload. Otherwise it can cause machine damage or accidents.



Mandatory

Configure the external circuit to turn on power according to the following sequence.

Turn on the power of model 2000

→ Turn on the power for the I/O module and external load power supplies

Otherwise, it can cause machine damage, malfunction or accidents.



Forbidden

Turn off power immediately if the S2T or related equipment emitting smoke or odor. Operation under such situation can cause fire or electrical shock. Also unauthorized repairing will cause fire or serious accidents. Do not attempt to repair. Contact Toshiba for repairing.



Mandatory

It is recommended to use an external power supply that provides power for both the I/O module and the loads. If not possible, configure the external circuit so that the external power required for output modules and power to the loads are switched ON/OFF simultaneously.

Also, be sure to turn off power to the loads before turning off power to the S2 T for system safety.

5. Safety Precautions on Maintenance and Inspection



WARNING



Mandatory

Turn off power when removing any units, modules, terminal blocks or wired cables after installing.

Otherwise exposed conductive parts of wire or on the rear of terminal blocks can cause electrical shock.



Forbidden

Do not disassemble or modify the S2T and related equipment in hardware nor software. Otherwise it can cause failure, malfunction, electrical shock or injury.



Forbidden

Be sure not to connect the opposite electrode of the battery or charge, the battery. Also, do not try to disassemble the battery or make it short-circuited or throw it into fire or use it in overheated condition. Otherwise it can cause fire or explosion.

CAUTION



Forbidden

Be careful not to hit or fall off the model 2000 by accident.
Excess shock can cause failure.



Mandatory

Touch a grounded metal part to discharge the static electricity on your body before touching the model 2000.
Otherwise, charged static electricity on your body can cause malfunction or failure.



Mandatory

Use soft cloth to clean the model 2000.
Use water-dipped and squeezed cloth to clean it if dirty.
Leaving the model 2000 dirty can cause mistaking or malfunction.



Mandatory

Place any modules removed from the unit on a conductive mat or conductive bag (containing a spare board, etc.) on an grounded desk.
Otherwise, static electricity can damage components of the module.



Forbidden

Do not apply benzene and thinner when cleaning the model 2000.
Otherwise, it can cause deformity or discoloration the panel or case of the model 2000.

6.Safety Precautions on Replacing Components

WARNING



Mandatory

Turn off power of the model 2000 before replacing the power fuse or warning fuse.
Otherwise, it can cause electrical shock or fire.



Mandatory

Replace the fuse or battery with a new one specified.
Otherwise, it may malfunction or cause fire.



Mandatory

The relays used in the relay output module have ON/OFF life mechanically. Use them within their mechanical life times is described in this manual. Replace the module if exceeded.

CAUTION



Mandatory

In an annual average temperature of 30°C or less, replace the battery every four years; replace it every two years in an average annual temperature higher than 30°C. An exhausted battery can cause malfunction and lose data and programs stored in S2T, resulting in machine damage or accidents, depending on the application.

7. Safety Precautions in Daily Operation

WARNING



Mandatory

Apply power of the specified ratings (voltage fluctuation range, frequency, output rating, etc.) described in this manual. Otherwise, it can cause malfunction, machine damage or fire due to overheat.



Mandatory

Turn off power immediately if the ambient temperature or internal temperature exceeds beyond normal range or if failure is occurred in the model 2000. Contact Toshiba for repairing. Operation under such situation can cause fire or electrical shock.

CAUTION



Forbidden

Do not touch any components, terminals, connectors or printed circuit boards in the module.

Otherwise, it can cause the IC or LSI or the like to be broken by static electricity, resulting in failure or malfunction.

Also, the edge of components can cause injury.



Forbidden

Do not forcibly bend or pull or distort the power cord and other cables. Otherwise, they can be cut off or cause overheat.



Forbidden

Do not disassemble or modify the S2T and related equipment.

Otherwise, it can cause malfunction or failure.



Forbidden

Do not enter wire scraps or other foreign debris into the S2T and related equipment. Also, do not insert metal parts into them. They can cause fire or accidents.

8. Safety Precautions on Disposal

WARNING



Forbidden

Do not throw lithium batteries into fire. Otherwise, they can explode.

CAUTION



Mandatory

Observe local regulations for disposal of the lithium batteries or the model 2000.

Limitation of Applications

- The model 2000 has been designed and manufactured for use in an industrial environment. However, the model 2000 is not intended to be used for systems which can endanger human life (note 1).
- Consult Toshiba if you intend to use the model 2000 for a special application which involves human life and has great influence on the maintenance of the public function (note 2). This is why such application requires special care on the operation, maintenance, and control of the system (note 3).

(Note 1) The systems which can endanger human life are life maintenance systems, equipment installed in the surgery, and other medical equipment.

(Note 2) The systems which involve human life and have great influence on the maintenance of the public function mean the main control system of a nuclear power plant, safety and protection system of a nuclear power facility, transport operation and control systems for mass transportation, control systems of aviation and space systems, and other systems and subsystems where safety is critical.

(Note 3) "Special care" means to build a safety system (foolproof design, fail safe design, redundancy design, etc.) in full consultation with Toshiba's engineers.

Immunity

- Toshiba is not liable for any loss caused by fire, earthquake, action by a third party, or other accidents, or the operator's intentional or accidental misuse, incorrect use, or use under abnormal condition.
- Toshiba is not liable for any incidental loss caused by the use or non-use of this product, such as loss of business profits, suspension of business, or loss or change of data on memory.
- Toshiba is not liable for the loss caused by an operation contradictory to any of the instructions stated in this manual.
- Toshiba is not liable for the loss caused by an incorrect operation in combination with other equipment.
- Toshiba is not liable for the loss caused by a malfunction in combination with an application program made by the customer.

NOTE:

Use cellular phones and PHSs at least one meter away from the working the model 2000 transmission cables, and I/O bus cable. Otherwise, the system can malfunction.

About this manual

This manual describes an overview, specification, and installation, operation, and maintenance and inspection of the hardware of Toshiba's sequence controller S2T for the Integrated Controller Vseries model 2000 (hereinafter called "S2T," which is also called "model 2000" or the "equipment" when no distinction is needed).

The following types of S2T are available to realize cost-performance suited to your application.

- PU662T: CPU station module, 32K-steps, 90 ns/basic instruction, RS485 port
- PU672T: CPU station module, 64K-steps, 90 ns/basic instruction, RS485 port, 1MB memory

At first, be sure to read "Safety Precautions" before operating the model 2000.

Read this manual thoroughly before using the S2T. Also, keep this manual and related manuals so that you can read anytime while the S2T is in operation.

This manual has been written for users who are familiar with Programmable Controllers and industrial control equipment. Contact Toshiba if you have any questions about this manual.

The S2T Related Manual

The following documents are available for S2T .

S2T User's Manual - Basic Hardware (6F8C0926)

Describes the S2T system configuration, and explains the specifications, installation, wiring, maintenance and troubleshooting for the S2T's basic hardware.

S2T Use's Manual - Functions (6F8C0928)

Provides the information for designing S2T user program, such as S2T internal operation, memory configuration, I/O allocation.

T Series Instruction Set (Ladder, SFC) (UM-TS03***-E004)

Detailed explanations of ladder and SFC programming, two of the languages of the S2T/T3H/T3/T2N/T2E/T2/T1S/T1 programmable controllers.

T-PDS for Windows Basic Operation Manual (UM-TS03***-E038)

Installation and basic key operations of the T-series Program Development System (T-PDS) software for windows.

T series Computer Link Function User's Manual (UM-TS03***-E008)

Describes the Tseries computer link configuration, and explains the protocol, software procedure, wiring to communicate between the Tseries PCs.

High Function Analog Module User's Manual (6F8C0860)

Describes the specifications and operation of high function Analog Module (AD668/DA664/TC618/RT614).

Pulse Input Module Manual (PI632/PI672) (6F8C0841)

Describes the specifications and operation of Pulse Input Module (PI632/PI672).

Communication Interface Module Manual (CF611) (6F8C0843)

Describes the specifications and operation of Communication Interface Module (CF611).

2-Axis Positioning Controller Manual (MC612) (6F8C0842)

Describes the specifications and operation of 2-Axis Positioning Module(MC612).

TOSLINE-S20 User's Manual (6F8C0890)

Describes the system configuration, and explains the functions, performance and operation of TOSLINE-S20.

TOSLINE-F10 User's Manual (6F8C0844)

Describes the system configuration, and the specifications, wiring and operation of remote I/O data link system TOSLINE-F10.

DeviceNet Scanner Module Manual (6F8C0845)

Describes the system configuration, and explains the specifications, installation, wiring of Device Net.

Ethernet Module Operation Manual (6F8C0879)

Describes the specifications, wiring and operating of Ethernet Module (EN611/EN631/EN651)

CONTENTS

Safety Precautions	i
Limitation of Applications	x
Immunity	x
About this manual	xi
The S2T Related Manual	xii
Chapt1 System Configuration.	1
1.1 S2T configuration as Station Module	2
1.1.1 S2T basic configuration.	2
1.1.2 S2T System configuration	3
1.1.3 Unit configuration	5
1.2 S2T CPU Module	10
1.2.1 Overview	10
1.2.2 Status display LEDs	11
1.2.3 Operation Mode Switch.	11
1.2.4 Setting Switches of Operation Mode	12
1.2.5 Programmer port of RS232C	13
1.2.6 LINK port of RS485	14
1.3 Computer link mode	18
1.3.1 Computer link function	18
1.3.2 System configuration.	19
1.3.3 Setup procedure	20
1.3.4 RS-485 cable connection	21
1.3.5 RS-232C cable connection	23
1.3.6 Mode setting	23
1.3.7 Communication parameter setting	24
1.3.8 Computer link protocol	25
1.4 Free ASCII mode.	27
1.4.1 Free ASCII communication function	27
1.4.2 System configuration.	29
1.4.3 Setup procedure	30
1.4.4 RS-485 cable connection	31
1.4.5 Mode setting	32
1.4.6 Communication parameter setting	33

CONTENTS

1.4.7	Message format	34
1.4.8	Programming	35
1.4.9	Related instruction	40
1.4.10	Sample programs	48
1.5	Units	51
1.5.1	Bases	51
1.5.2	Expansion interface	53
1.5.3	Expansion cables	53
1.6	Power Supply Module	54
1.6.1	Power Supply Module	54
1.6.2	Power capacity consideration	57
1.7	I/O Modules	60
1.8	Network Modules	62
Chapt2 Specifications		65
2.1	General Specifications	65
2.2	External dimensions	68
2.3	I/O Module Specification	70
Chapt3 Precautions for I/O Modules		111
3.1	Precautions for DC Input Modules	111
3.2	Precautions for AC Input Modules	115
3.3	Precautions for DC Output Modules	117
3.4	Precautions for AC Output Modules	120
3.5	Precautions for Relay Output Modules	121
3.6	Precautions for Analog Input Modules	122
3.7	Precautions for Analog Output Modules	123
Chapt4 Installation and Wiring		125
4.1	Operating environment	125
4.2	Installing bases	126
4.3	Mounting the Modules	127

CONTENTS

4.3.1	Basic procedure for mounting/removing the modules . . .	127
4.3.2	Installing/removing of the module cover	131
4.4	Connecting expansion units	132
4.5	Grounding	133
4.5.1	Check points for grounding	133
4.5.2	Grounding methods.	134
4.6	Wiring of the power supply	136
4.7	I/O wiring.	139
4.8	Wiring of the computer link	141
4.9	Power up/down sequence.	143
4.10	Safety circuit	144
Chapt5 Maintenance and Checking		145
5.1	Daily checking items	145
5.2	Periodical checking items	146
5.3	Maintenance parts	147
5.4	Battery Replacement	148
	Disposal of the battery 150	
5.5	Fuse Replacement	151
Chapt6 Troubleshooting		153
6.1	Troubleshooting procedure	153
6.2	Checking the power supply	155
6.3	Checking the S2T CPU.	156
6.4	Checking user program.	157
6.5	Checking input	158
6.6	Checking output	159
6.7	Troubles due to external factors	160

Chapt.1 System Configuration

The Integrated Controller Vseries has some features as mentioned before. The Station Module with station bus (internal high-speed data bus) interface can perform to exchange common data between them on real time.

- Station Module

The Station Module is shown as below table. These can be mounted on the dedicated basic base and perform complex control combining each functionality.

Table1-1 S2T CPU

Description	Specification	Type	Remarks
Sequence Controller	32K-step	PU662T	
	64K-step	PU672T	

Table1-2 Station Module

Item	Description	Specification	Type	No. of Occupied slot
Controller	Sequence Controller	32K-step	PU662T	1
		64K-step	PU672T	1
	Compute	Windows-NT HDD	C2PU35	2
Network	Ethernet	10BASE5	EN611	1
		10BASE2	EN631	1
		100BASE-TX, 10BASE-T	EN651	1
	TC-net10	16KW, 10Mbps,co-axial	CN611	1
		16KW, 10Mbps,co-axial, Double bus	CN612	1
	TC-net20	16KW, 20Mbps,optical,Double Loop bus	CN623 ^{*1}	1

*1: under development

*2: The above modules are performed on the main base with station bus.
Please refer to Section 1.1 or 1.3 for details of the system configuration.

1.1 S2T configuration as Station Module

1.1.1 S2T basic configuration

According to variety of industrial applications, a basic unit or with expansion units are selected.

The basic unit is composed of a main base, a power supply module, station modules and direct I/O modules, and an expansion interface is added using expansion units.

The expansion unit is composed of an expansion base, a power supply module, direct I/O modules and an expansion interface.

Each expansion interface modules are connected with expansion cables.

Up to three expansion units can be connected in the S2T.

The S2T accesses direct I/O modules via the G2-bus in the model 2000.

1

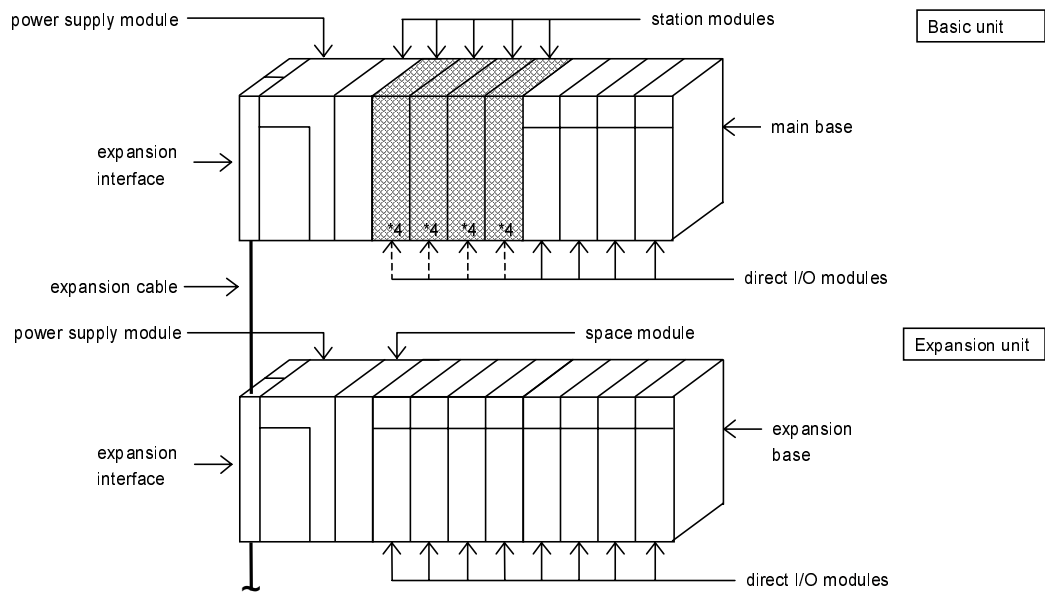

*4: The digital / analog I/O modules can be mounted in the *4 slots in place of the station modules.

Fig.1-1-1 An example of S2T basic configuration as station module

1.1.2 S2T System configuration

The S2T provide a functional, economical and compact solution to user applications in automotive, machine control and process control, by using station modules and direct I/O modules.

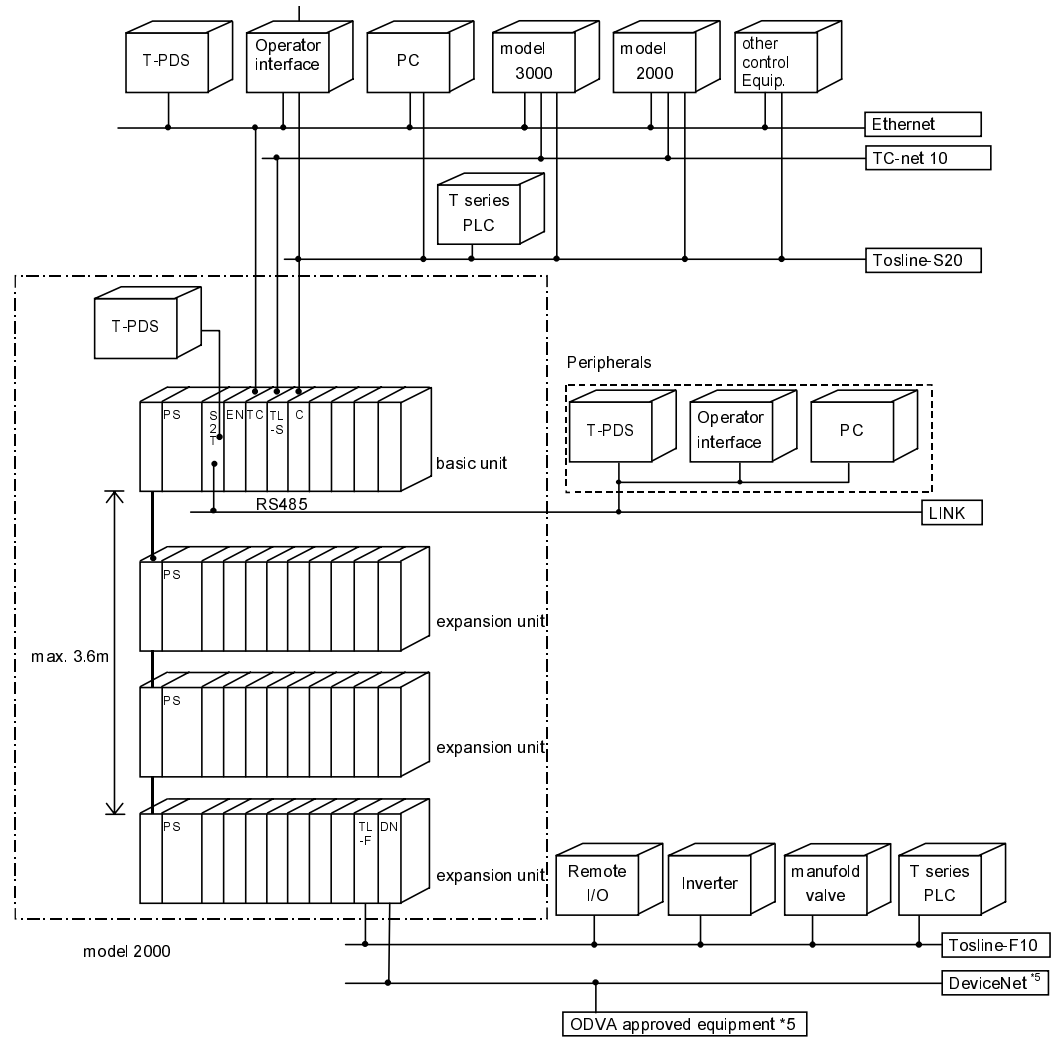

1

*5: DeviceNet is a registered trademark of the Open DeviceNet Vender Association, Inc.

Fig.1-1-2 An example of S2T system configuration as station module

• Basic configuration

Base

Main base	BU648E
	BU643D
Expansion base	BU668
	BU666
	BU664

Power supply module

100, 200Vac input	PS691
100-240Vac input	PS693
100-240Vac input	PS694
24Vdc input	PS632
100Vdc input	PS652

S2T CPU module

32k-step	PU662T
64k-step	PU672T

Expansion interface

Standard	IF661
----------	-------

Optional

Space module	SP600
Unit cover	SP601

Expansion cable for standard

0.3m	CS6R3
0.5m	CS6R5
0.7m	CS6R7
1.2m	CS6*1

• Station Module

Control module

Computer	C2PU35
----------	--------

Network module

TOSLINE-S20	SN625
	SN626
	SN627
TC-net10	CN611
	CN612
TC-net20	CN623*1

Open Network module

Ethernet	EN611
	EN631
	EN651

Serial, CompactFlash interface

Serial, Compact-flash interface	CF612*1
---------------------------------	---------

•Software tool

Programming tool T-PDS

Windows-NT/98 (Japanese)	MW33J2
Windows-NT/98 (English)	MW33E2

TOSLINE-S20 tool S-LS

Windows-/NT/98 (Japanese)	MW23J*
Windows-/NT/98 (English)	MW23E*

DDE server soft

Japanese Edition	PV33J2
English Edition	PV33E2

Connecting cable

5m	CJ905
----	-------

• Direct I/O module

Digital input/output module

24Vdc input	DI632D
	DI633
	DI634
	DI635
	DI635H
100-120Vac input	IN653
200-240Vac input	IN663
Transistor output (source type)	DO633
	DO634
	DO635
	DO633P
Triac output	AC663
Relay output	RO662S
	RO663
Changeect detect	CD633

Analog input/output module

Analog input	AD624
	AD674
	AD628S
	AD638S
	AD668
Analog output	RT614
	TC618
	DA622
	DA672
	DA664

Serial interface

Serial interface	CF611
------------------	-------

Network module

TOSLINE-S20	SN621*4
	SN622*4
TOSLINE-F10	UN611
	UN612

Network module

DeviceNet	DN611A
FL-net	FL611
	FL612

Intelligent I/O module

Pulse input	PI632
	PI672
Positioning control	MC612
	MC614*1

*1: under development

*4: function limited

1

1.1.3 Unit configuration

Some examples of minimum/maximum configuration are shown as below.

Basic unit

The main base dedicated for station module is used. The control module S2T should be mounted on S0 that is the left end slot of the base. Other station modules are mounted on from S1 to S4 (BU648E) where two connectors are.

The digital/analog input/output module can be mounted on slots for station module. These modules should be mounted on the right slot of station modules.

Table1-1-1 Main base

Type	Description	Slot No. for Station Module	Slot No. for Direct I/O Module	Remarks
BU648E	For Basic unit	5	4	
		4	5	
		3	6	
		2	7	
		1	8	
BU643D	For Basic unit	4	0	
		3	1	
		2	2	
		1	3	

1

Expansion unit

Table1-1-2 Expansion base

Type	Description	Space slot No.	Slot No. for Direct I/O Module	Remarks
BU668	For Expansion unit	1	8	
BU666		0	6	
BU664		0	4	

Module implementation from base view

Table1-1-3 Basic unit Module implementation

	Slot										
	PIF	PS	0	1	2	3	4	5	6	7	8
BU648E	-	-	CPU	ALL	ALL	ALL	ALL	IO	IO	IO	IO
BU643D	-	-	CPU	ALL	ALL	ALL					

Table1-1-4 Expansion unit Module implementation

	Slot										
	PIF	PS	0	1	2	3	4	5	6	7	8
BU668	-	-	×	IO	IO	IO	IO	IO	IO	IO	IO
BU666	-	-	IO	IO	IO	IO	IO	IO			
BU664	-	-	IO	IO	IO	IO					

NOTE

PIF:Slot for expansion interface IF661
 PS:Slot for power supply module
 0 to 8:Slot number of base
 CPU:Slot for CPU module S2T
 IO:Slot for I/O module
 All:Slot for Station module,I/O module

Module implementation from each module view

Table1-1-5 CPU module

	One module occupied slot	Slot				
		BU648E	BU643D	BU668	BU666	BU664
PU672T	1	0	0	×	×	×
PU662T	1	0	0	×	×	×
C2PU35	2	1 ~ 3	1 ~ 2	×	×	×

S2T(PU672T,PU662T) used in Basic unit slot number "0".

Table1-1-6 expansion interface

	Slot				
	BU648E	BU643D	BU668	BU666	BU664
IF661	PIF				

Table1-1-7 Network module

	Slot				
	BU648E	BU643D	BU668	BU666	BU664
EN651	1 ~ 4	1 ~ 3	×	×	×
EN611	1 ~ 4	1 ~ 3	×	×	×
EN631	1 ~ 4	1 ~ 3	×	×	×
SN625	1 ~ 4	1 ~ 3	×	×	×
SN626	1 ~ 4	1 ~ 3	×	×	×
SN627	1 ~ 4	1 ~ 3	×	×	×
UN611	5 ~ 8	×	1 ~ 8	0 ~ 5	0 ~ 3
UN612	5 ~ 8	×	1 ~ 8	0 ~ 5	0 ~ 3
DN611A	1 ~ 8	×	1 ~ 8	0 ~ 5	0 ~ 3
FL611	1 ~ 8	×	1 ~ 8	0 ~ 5	0 ~ 3
FL612	1 ~ 8	×	1 ~ 8	0 ~ 5	0 ~ 3

Table1-1-8 Direct I/O module, others

	Slot				
	BU648E	BU643D	BU668	BU666	BU664
DI632D	1 ~ 8	1 ~ 3	1 ~ 8	0 ~ 5	0 ~ 3
DI633	1 ~ 8	1 ~ 3	1 ~ 8	0 ~ 5	0 ~ 3
DI653	1 ~ 8	1 ~ 3	1 ~ 8	0 ~ 5	0 ~ 3
DI634	1 ~ 8	1 ~ 3	1 ~ 8	0 ~ 5	0 ~ 3
DI635	1 ~ 8	1 ~ 3	1 ~ 8	0 ~ 5	0 ~ 3
DI635H	1 ~ 8	1 ~ 3	1 ~ 8	0 ~ 5	0 ~ 3
IN653	1 ~ 8	1 ~ 3	1 ~ 8	0 ~ 5	0 ~ 3
IN663	1 ~ 8	1 ~ 3	1 ~ 8	0 ~ 5	0 ~ 3
DO633	1 ~ 8	1 ~ 3	1 ~ 8	0 ~ 5	0 ~ 3
DO633P	1 ~ 8	1 ~ 3	1 ~ 8	0 ~ 5	0 ~ 3
DO634	1 ~ 8	1 ~ 3	1 ~ 8	0 ~ 5	0 ~ 3
DO635	1 ~ 8	1 ~ 3	1 ~ 8	0 ~ 5	0 ~ 3
AC663	1 ~ 8	1 ~ 3	1 ~ 8	0 ~ 5	0 ~ 3
RO662S	1 ~ 8	1 ~ 3	1 ~ 8	0 ~ 5	0 ~ 3
RO663	1 ~ 8	1 ~ 3	1 ~ 8	0 ~ 5	0 ~ 3
CD633 *1	1 ~ 8	1 ~ 3	1 ~ 8	0 ~ 5	0 ~ 3
AD624L	1 ~ 8	1 ~ 3	1 ~ 8	0 ~ 5	0 ~ 3
AD634L	1 ~ 8	1 ~ 3	1 ~ 8	0 ~ 5	0 ~ 3
AD624	1 ~ 8	1 ~ 3	1 ~ 8	0 ~ 5	0 ~ 3
AD674	1 ~ 8	1 ~ 3	1 ~ 8	0 ~ 5	0 ~ 3
AD628S	1 ~ 8	1 ~ 3	1 ~ 8	0 ~ 5	0 ~ 3
AD638S	1 ~ 8	1 ~ 3	1 ~ 8	0 ~ 5	0 ~ 3
AD668	1 ~ 8	1 ~ 3	1 ~ 8	0 ~ 5	0 ~ 3
TC618	1 ~ 8	1 ~ 3	1 ~ 8	0 ~ 5	0 ~ 3
RT614	1 ~ 8	1 ~ 3	1 ~ 8	0 ~ 5	0 ~ 3
DA622L	1 ~ 8	1 ~ 3	1 ~ 8	0 ~ 5	0 ~ 3
DA622	1 ~ 8	1 ~ 3	1 ~ 8	0 ~ 5	0 ~ 3
DA672	1 ~ 8	1 ~ 3	1 ~ 8	0 ~ 5	0 ~ 3
DA664	1 ~ 8	1 ~ 3	1 ~ 8	0 ~ 5	0 ~ 3
PI632 *1	5 ~ 8	×	1 ~ 8	0 ~ 5	0 ~ 3
PI672 *1	5 ~ 8	×	1 ~ 8	0 ~ 5	0 ~ 3
MC612	5 ~ 8	×	1 ~ 8	0 ~ 5	0 ~ 3
CF611	5 ~ 8	×	1 ~ 8	0 ~ 5	0 ~ 3

*1: When you use CD633, PI632, PI672 with interrupt function, implement in the Basic unit in which S2T exists.

(1) Minimum Configuration

● Examples of BU648E

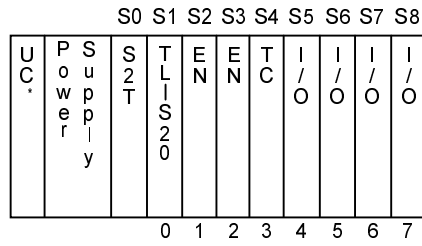

Main unit with 5 station modules and 4 I/O modules

UC*: unit cover

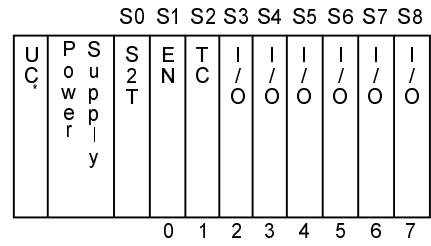

Main unit with 3 station modules and 6 I/O modules

● Examples of BU643D

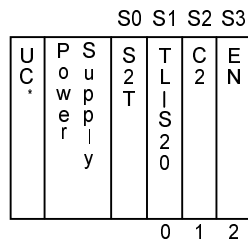

Using high performance CPU, 4 slots

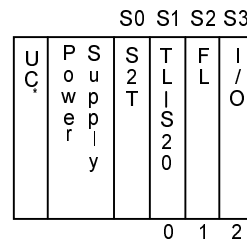

Using high performance CPU, 2 slots

1

NOTE

- i. Sn (n=0 to 8) on upper side is called slot number and m (m=0 to 7) on lower side is called I/O module address in the above.
- ii. Do not use the following combinations.

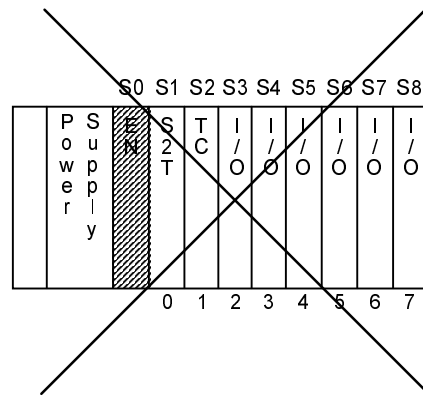
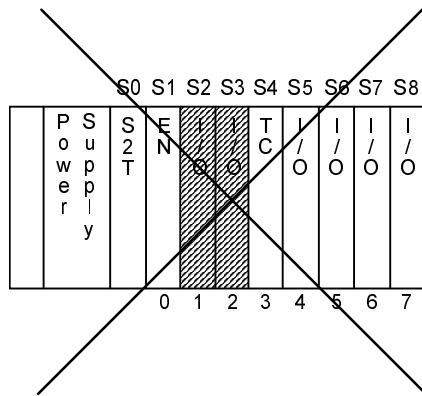

- iii. Install the unit cover on the left end slot of base, to avoid the risk of electrical shock.

(2) Maximum Configuration

Number of I/O points (using 64-point I/O module)

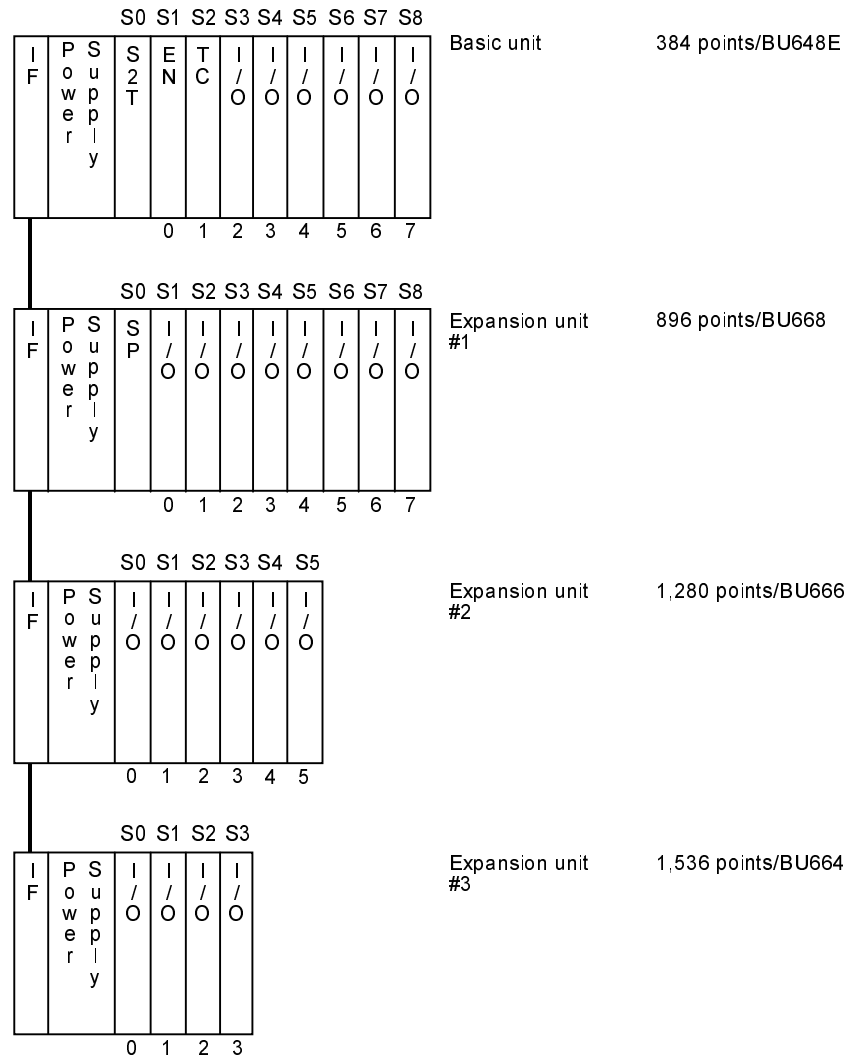

1

NOTE

- iv. The expansion interface should be mounted on each unit.
Two expansion connectors are fitted on the expansion interface. The upper side connector is for input from previous unit and the lower side connector is for output to the next unit.
- v. Up to a maximum of 3 expansion units can be connected.
- vi. There is no limit on combinations of the types of the rack.
- vii. Using BU668, the S0 slot can't be used and a space module SP600 should be mounted on S0. The space module SP600 should be mounted on other vacant slots to avoid the risk of electrical shock.

1.2 S2T CPU Module

1.2.1 Overview

The S2T CPU module performs user program, reading input data from the direct I/O module and writing output data to the direct I/O module.

The S2T has two types of CPU modules.

Type	Program language	Program Capacity	Battery	Memory	Expanded memory	Link port
PU662T	Ladder + SFC	32KS	Built-in	RAM + FlashROM	—	RS485
PU672T		64KS			1MB	Built-in

When user program and parameter data are kept in the built-in flash ROM of the S2T, user system will come back to be well quickly if any trouble occurs.

The S2T has the built-in two communication ports, one Programmer port and one LINK port which is equipped for variety of peripherals, displays and PCs etc.

The front view of the S2T is shown as below. The operation mode switch, setting switches of operation mode, status display LEDs are provided on the front panel.

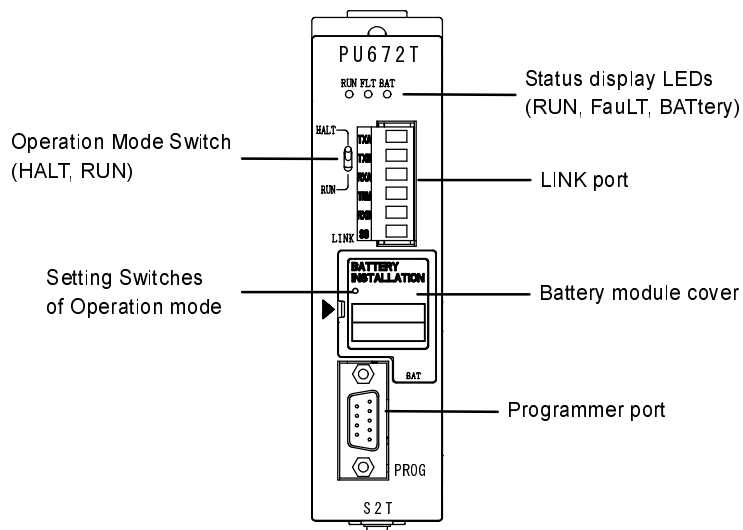

Fig.1-2-1 S2T CPU front view

1

1.2.2 Status display LEDs

These LEDs show operation states of the S2T.

Status display LEDs

Name	Display	States	Remark
RUN (Green)	Lit	Operating state (RUN Mode)	
	Blink	HOLD Mode	
	Out	Stopped state (HALT Mode) or Error Mode	
FLT (Red)	Lit	CPU abnormal or I/O abnormal	
	Blink	CPU abnormal	
	Out	Normal	
BAT (Green)	Lit	Battery normal	
	Blink	Battery caution	
	Out	Battery abnormal or no battery	

1.2.3 Operation Mode Switch

The Operation Mode Switch is provided on the CPU module.

This switch controls S2T operation (RUN/HALT).

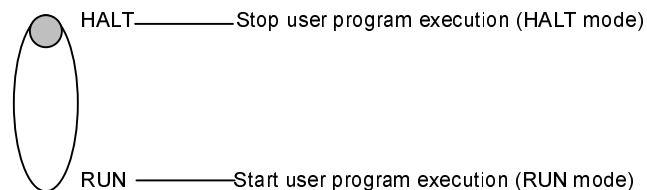

CPU status is shown below after power up or after the operation mode is changed to RUN from HALT mode.

Setting Position	Initial Load Program exe : executed - : not executed		Operation mode	Operation Mode Change by the Programming tool
HALT	SW-1=OFF	exe	HALT	Not available
	SW-1=ON	-		
RUN	SW-1=OFF	exe	RUN	available
	SW-1=ON	-		

As shown in the above table, initial load (user program transfer from Flash ROM to RAM) performs when setting SW-1 to OFF.

NOTE

- i. The operation mode switch is set to HALT at the factory.
- ii. Normally the programming is activated in the HALT mode.
- iii. For details of the operation mode, see "S2T user's manual".
- iv. The RAM is back-up by both internal capacitor and built-in battery of the S2T. When they go down and the S2T can't keep retentive area in the RAM, CPU checks user program BCC. CPU registers error if error is occurred.

1.2.4 Setting Switches of Operation Mode

These switches are provided under the battery cover on the CPU front panel.
They control the following functions. (SW-1 is ON, SW2, 3, 4 are set to OFF at the factory.)

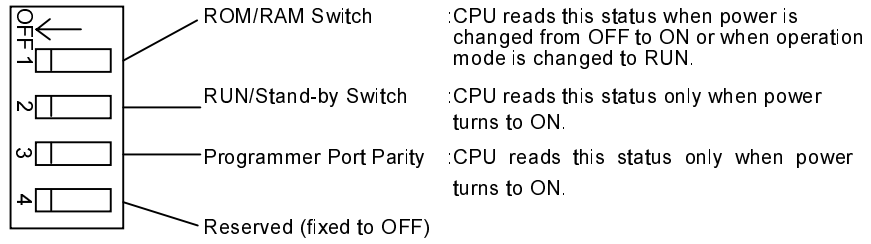

SW-1 ROM/RAM Switch

Setting Position SW-1	Function	CPU operation at power up and at the beginning of the RUN mode
OFF	ROM	Starts up after the content of the Flash ROM has been transferred to the RAM. (Initial Load)
ON	RAM	Starts up on the content of the RAM. (No program transfer)

SW-2 RUN/Stand-by Switch

Setting Position SW-2	Function	Operation Mode Switch	Mode after power up	Remarks
OFF	Automatic RUN	HALT	HALT	Automatic RUN start occurs.
		RUN	RUN	
ON	Stand-by	HALT	HALT	Starts up in the HALT mode. Ready to start operation by an operate command from the programming tool or by shifting the operation mode switch.(→HALT→RUN)
		RUN		

※SW-1 is OFF, mode is set to Automatic RUN.

SW-3 Programmer Port Parity

Setting Position SW-3	Function	Remarks
OFF	Odd Parity	8 bit Data, 9600bps, Data length is 11bit.
ON	No Parity	8 bit Data, 9600bps, Data length is 10bit.

⚠ CAUTION



Mandatory

Set the switches of the CPU and I/O modules according to each instructions.
Mis-setting can cause malfunction or system accidents.

1.2.5 Programmer port of RS232C

The programmer (T-PDS) is connected to this programmer port.
Connector type of CPU side is female , 9-pin D-SUB connector.

The S2T's RS232C programmer port can accept the computer link protocol (data read/write). This results in easy connection to a higher level computer, an operator interface unit, etc. directly.

General specifications and the connector pin assignment of programmer port are shown below.

For details of T-series computer link protocol, see T-series User's manual
- Computer Link (UM-TS03***-E008).

General specifications

Item	Specifications
Interface	Conforms to RS232C
Configuration	One to One
Transmission distance	15m max.
Transmission speed	9600bps (fixed)
Frame format	Start bit 1bit Data 8bit Parity odd/none (selected by SW.3) stop bit 1bit
Supported command	DR (Data Read) DW (Data Write) ST (Status read) TS (Test text)

1

Pin assignment of programmer port

Signals	No. of pins	Symbols	Direction
Transmission data	3	TXD	S2T → Host
Receive data	2	RXD	S2T ← Host
Signal ground	5	SG	S2T -- Host
Request To Send	7	RTS	S2T → Host
Clear To Send	8	CTS	S2T ← Host

NOTE

Other pins except the above table should not be connected.

1.2.6 LINK port of RS485

The S2T supports the following communication function mode on the LINK port.

Computer link mode

The computer link mode is used to connect between the S2T and a master computer (included an operator interface, etc.).

By preparing the communication software based on the Toshiba's computer link protocol on the master computer, the following functions become available by the master computer. The computer link protocol is a simple ASCII message communication system.

Up to 32 S2T can be connected to a master computer on the RS-485 communication line. (one-to-N configuration)

- Reading data (register/device value) from the S2T
- Writing data (register/device value) into the S2T
- Monitoring the S2T operation status (RUN/HALT/ERROR)
- Controlling the S2T operation mode (RUN/HALT)

The programmer can be connected to this link as a master computer.

1

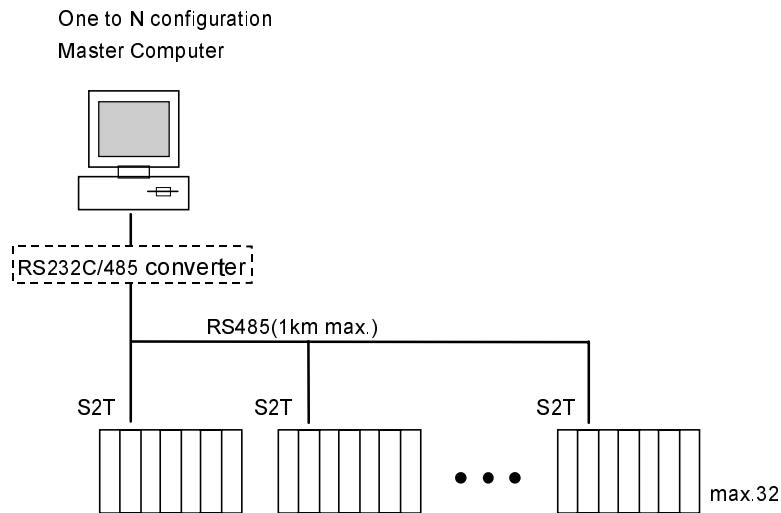
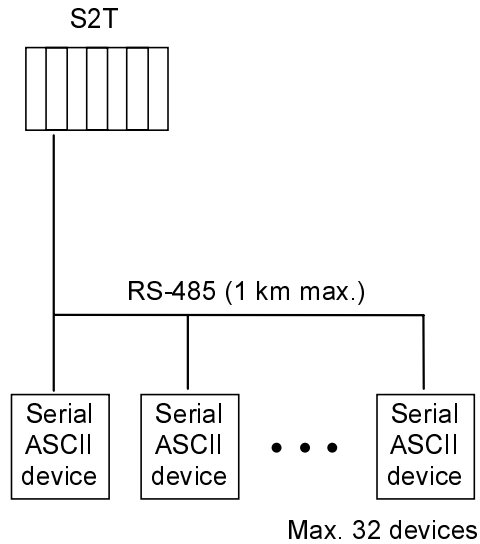

Fig.1-2-2 An example of computer link system configuration

Free ASCII mode

The free ASCII mode is used to connect between the S2T and various serial ASCII devices, such as a micro computer, bar code reader, printer, display, etc.

By using this mode, the S2T can work as a communication master. Therefore, the S2T can communicate with other PLCs using the computer link protocol, and can control variable speed drives (such as Toshiba's VF-S7) using its communication protocol



1

In this mode, user defined ASCII messages can be transmitted and/or received through the link port of the S2T.

The ASCII message (one set of transmission characters) means a string of ASCII characters which is ended by specified trailing code. The default setting of the trailing code is CR (carriage return code = H0D)

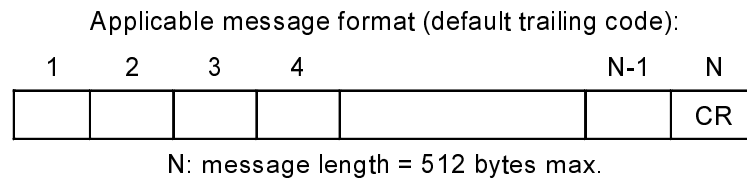

In other words, the S2T cannot be used for the data communication in which the transmission message is ended by two or more types of trailing code.

Transmission specifications

The communication parameter is set by writing it into the information memory of the S2T with the programmer.

Table1-2-1 Computer link mode

Item	Specifications
Interface	Conforms to RS-485 (4-wire system)
Transmission mode	Half-duplex
Synchronizing	Asynchronous
Transmission speed	300, 600, 1200, 2400, 4800, 9600, 19200 bps
Flame format	Start bit 1 bit (fixed) Data 7/8 bit Parity even/odd/none Stop bit 1/2 bit (NOTE)
Protocol	T-series computer protocol (ASCII), T-series programmer protocol (Binary)
Configuration	One to N (32 max.)
Transmission distance	1km max
Cable connection	6-pin removable terminal block

Table1-2-2 Free ASCII mode

Item	Specifications
Interface	Conforms to RS-485 (4-wire system)
Transmission mode	Half-duplex
Synchronizing	Asynchronous
Transmission speed	300, 600, 1200, 2400, 4800, 9600, 19200 bps
Flame format	Start bit 1 bit (fixed) Data 7/8 bit Parity even/odd/none Stop bit 1/2 bit (NOTE)
Transmission code	ASCII
Message length	512 bytes max
Configuration	One to N (32 max.)
Transmission distance	1km max
Cable connection	6-pin removable terminal block

NOTE

The following combinations of frame format are available.

Start bit	Data Length	Parity	Stop bit
1	7	non	2
1	7	even/odd	1
1	7	even/odd	2
1	8	non	1
1	8	non	2
1	8	even/odd	1

1

Pin assignment of LINK port

For details of wiring, see Section 1.3 or 1.4.

Signals	No. of pins	Symbols	Direction
Transmission data A	1	TXA	S2T→Master
Transmission data B	2	TXB	S2T→Master
Receive data A	3	RXA	Master←S2T
Receive data B	5	RXB	Master←S2T
Termination Resistor	4	TERM	—
Signal ground	6	SG	—

1.3 Computer link mode

1.3.1 Computer link function

In the computer link system, the S2T waits for receiving a request message issued from the master computer.

When a request message is issued, the S2T checks the station number contained in the request message. And when the station number designation matches the S2T's station number setting, the S2T processes the request and returns the response.

This is why each S2T must have a unique station number in the one-to-N configuration. Otherwise, more than S2T's may attempt to process the request, resulting in faulty response.

The following figure illustrates the processing sequence when a request to station number 3 is issued.

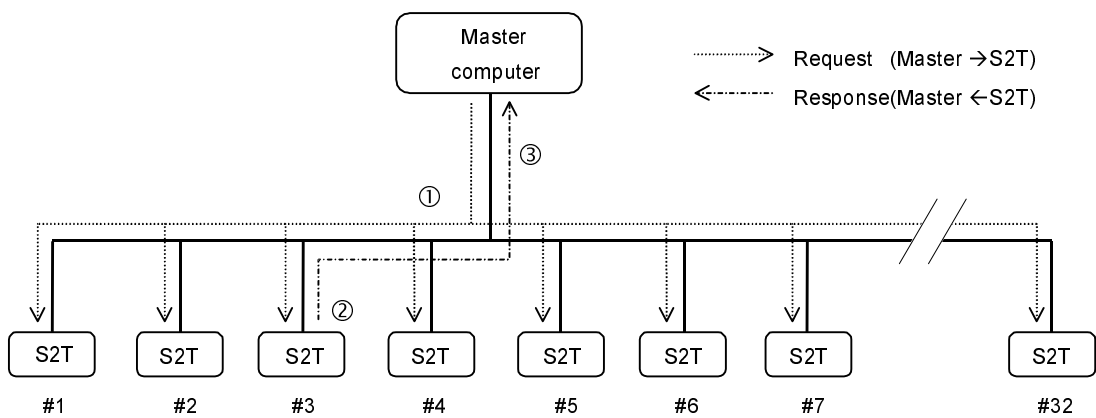

- ① The request message is sent from the master to all the connected S2T's. (request for station #3 in this example)
- ② The request message is interpreted and processed in the S2T which has the same station number as request. (station #3 S2T in this example)
- ③ Processing result is returned as response to the master.

NOTE

Available station number is 1 to 32. The station number is set in the S2T's system information memory.

1

Table1-3 Supplementary function for computer link

The following supplementary function are prepared for applying to various system control using computer link function.

S2T resister	Name	Function
SW038	Response delay mode on the programmer port (RS232C)	Setting value : 0-30 A response message is issued from the S2T after (setting value *10) ms.
SW057	Response delay mode on the LINK port (RS485)	Setting value : 0-30 A response message is issued from the S2T after (setting value *10) ms.

1.3.2 System configuration

The following figure shows the system configuration using computer link function.

S2T, link port (RS-485), one-to-N configuration (N is max. 32) is available. If the master computer has RS-232C interface only, the RS-232C/RS-485 converter (ADP-6237B) can be used.

S2T, programmer port (RS-232C), one-to-one configuration is available.



One-to-N configuration
(S2T : RS-485)

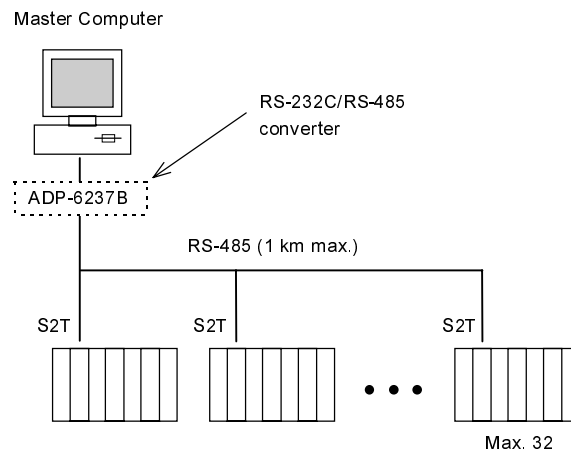

One-to-one configuration
(S2T : RS-232C)

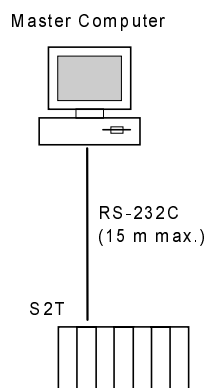

1.3.3 Setup procedure

The following chart shows the setup procedure of the computer link mode.

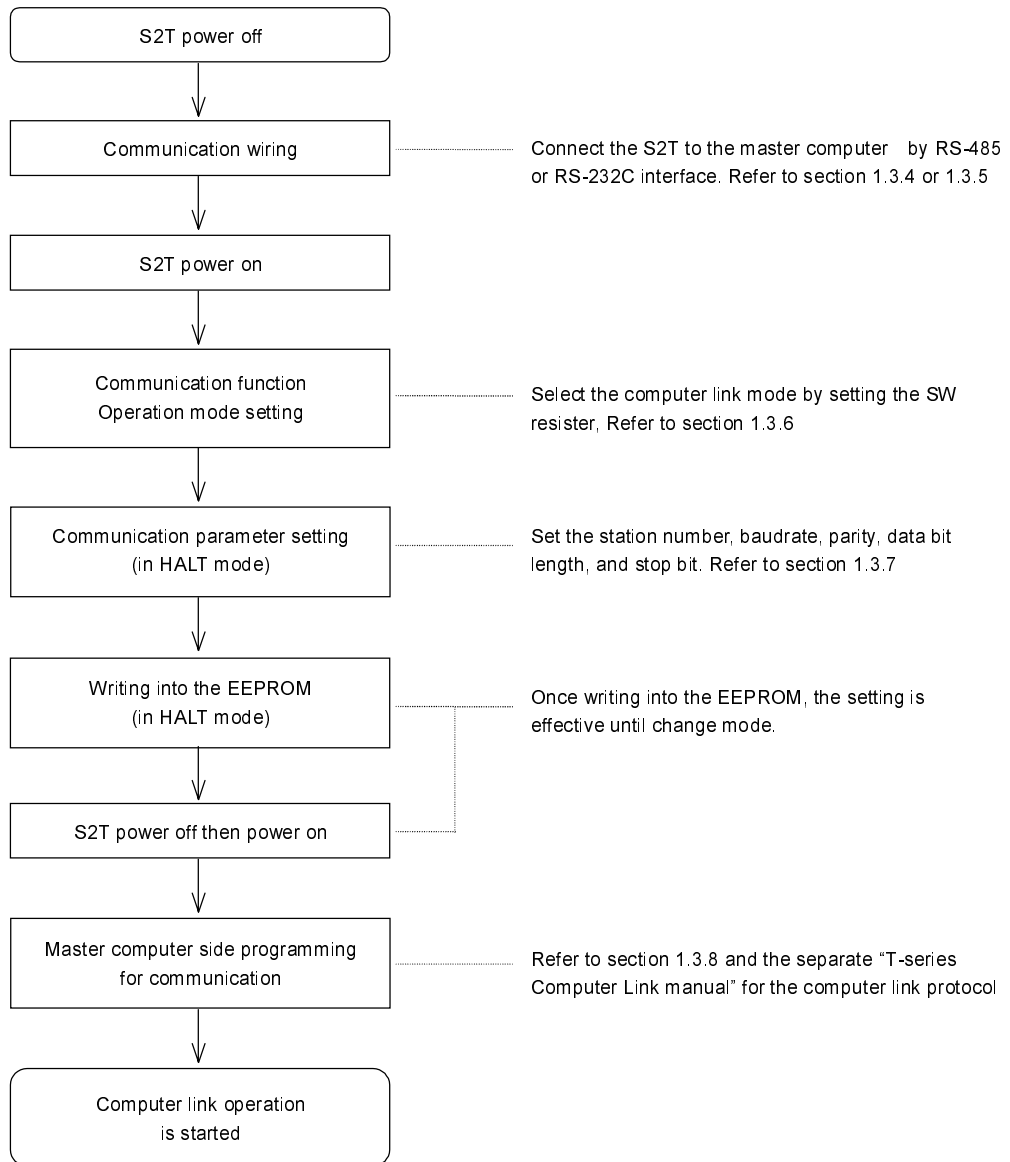

1

1.3.4 RS-485 cable connection

Cable connection examples show as below.

- Below figure shows an example of cable connection using the RS-232C/RS-485 converter (ADP-6237B).
- Use shielded twisted-pair cable for data communication suited to RS-485 standard. The cable shield should be connected to single-point ground.

One to one configuration

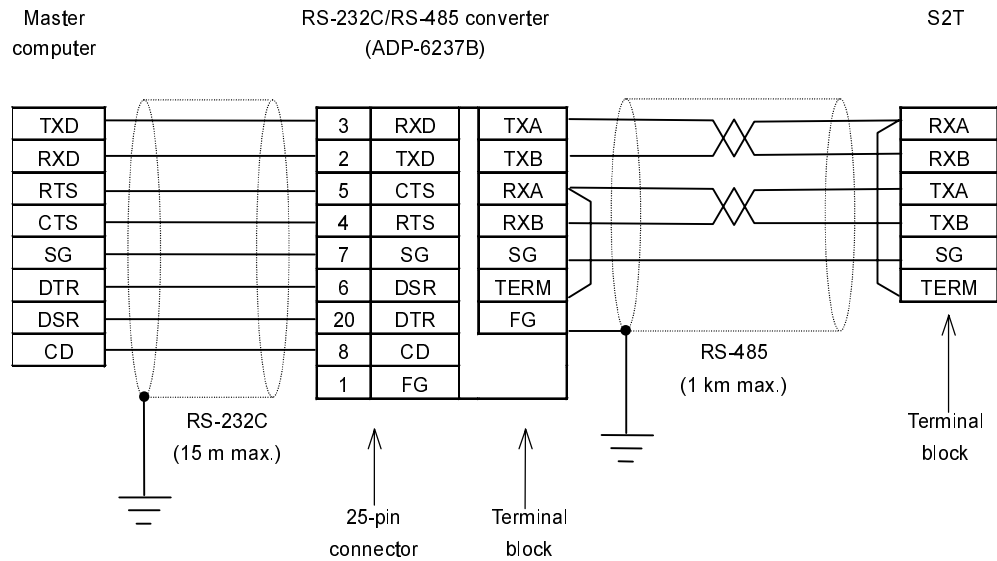

1

- S2T, removable terminal block is provided for cable connection.
- Short between RXA and TERM for termination at both the S2T and the ADP-6237B.
- If the master has RS-485 (or RS-422) interface and the S2T is connected to the master directly, connect termination resistor 1/2 W - 120 Ω between RXA and RXB at the master end.

One to N configuration

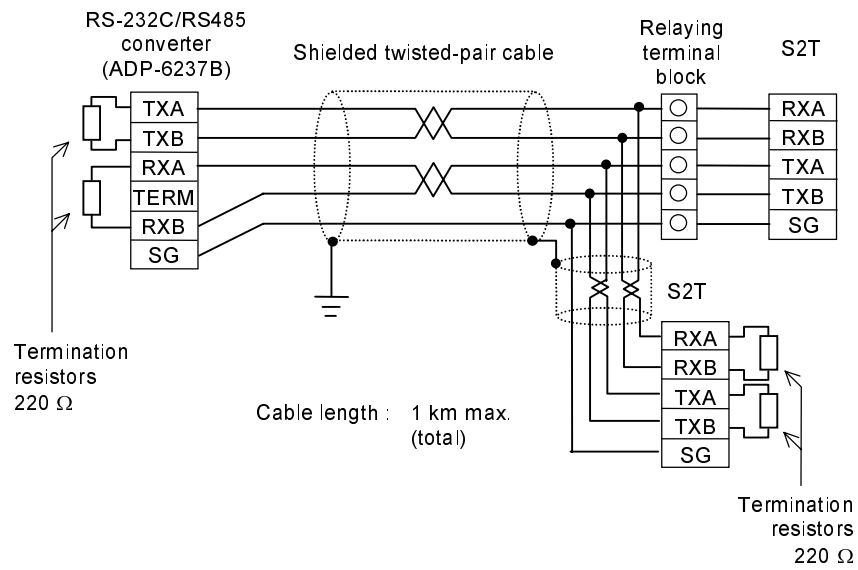

1

- S2T, removable terminal block is provided for cable connection.
- Connect termination resistor 1/2 W - 220 Ω between RXA and RXB, and between TXA and TXB at the both terminal stations.
- Use shielded twisted-pair cable for data communication suited to RS-485 standard. The cable shield should be connected to single-point ground.

1.3.5 RS-232C cable connection

Cable connection examples show as below.

- Use shielded twisted-pair cable for data communication suited to RS-232C standard. The cable shield should be connected to single -point ground.

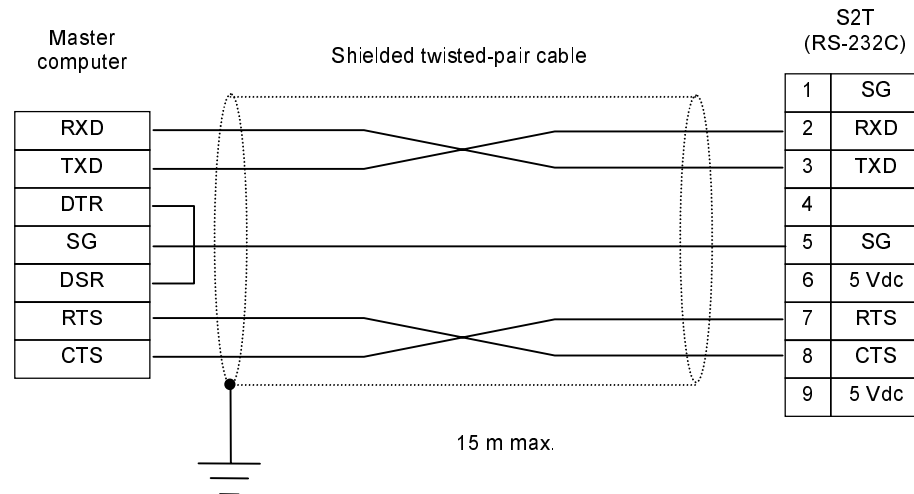

- S2T, D-Sub 9-pin female connector is provided. Use D-Sub 9-pin male connector as cable side.
- RTS signal (pin 7) of the S2T is ON while power on.
- CTS signal (pin 8) of the S2T has no mean on Communication control.

1.3.6 Mode setting

The operation mode of the S2T's link port is selected by the special resistor provided on the S2T CPU module.

The operation mode is internally set at the timing of power-up. Setting changes while power on is not effective.

To select the computer link mode, the special resistor SW069 set to "0". (SW069=0)

At the factory, the computer link mode is selected.

S2T resister	Name	Function
SW069	link port operation mode	0: computer link mode 2: Free ASCII mode

1.3.7 Communication parameter setting

The communication parameter is set by writing it into the system information memory of the S2T.

Turn the S2T to HALT mode, then set the communication parameter in the system information.

(T-PDS screen example)

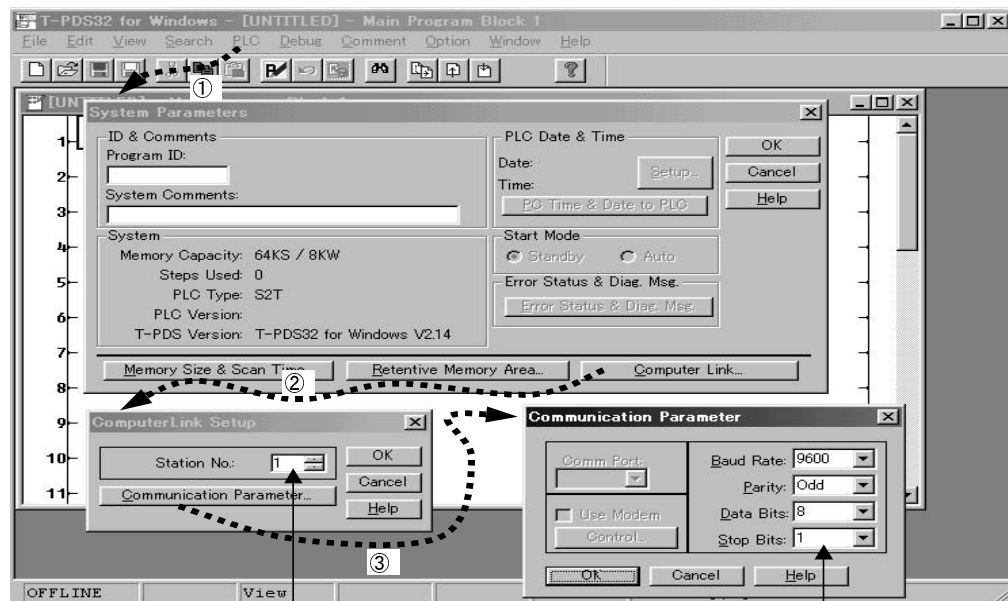

Set station number, baudrate, parity, data bit length, and stop bit.

After the communication parameter setting, write it into the S2T's built-in EEPROM before turning off power.

1.3.8 Computer link protocol

This section introduces the general message format of the T-series computer link protocol and the types of commands which are used for the S2T.

For details of the T-series computer link protocol, refer to the separate manual "T-series Computer Link Operation Manual".

General message format

Max.255bytes

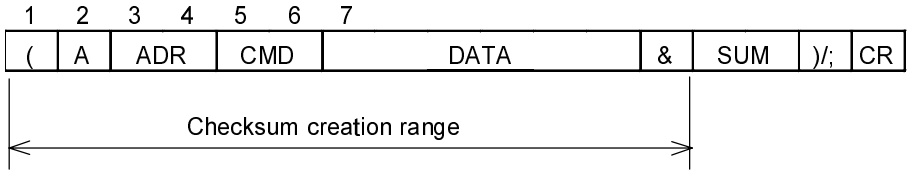

1

Text contents

(.....	Start code (H28)	1byte
A	Format identification code (H41)	1byte
ADR	Station number 01(H3031) through 32(H3332)	2byte
CMD	Command	2byte
DATA	Data field - depending on the command (max.244bytes)	
&	Checksum delimiter (H26)	1byte
SUM	Checksum ASCII code of the lowest one byte of the sum obtained by adding from the start code '(' to the checksum delimiter '&'. See the following example.	2byte
)	End code (H29)	1byte
;	End code (H3B) in case of halfway of entire data	1byte
CR	Carriage return code (H0D)	1byte

Checksum creation example:

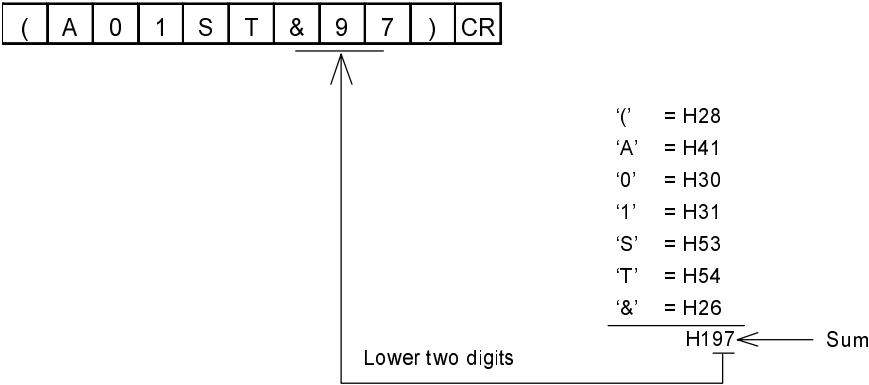

List of computer link commands supported by the S2T

The following computer link commands are available for the S2T.

Request command	Function name	Description	Response command	Remarks
-	Computer Link Error Response	Format error was detected in the request message	CE	Response only
-	PLC Error Response	The request command was rejected by S2T	EE	Response only
TS	Test	Loop back test S2T returns the same text	TS	
ST	PLC Status Read	Reads S2T operation status	ST	
ER	PLC Error Status Read	Reads error code registered in the S2T	ER	
DR	Data Read	Reads registers/devices data from the S2T	DR	
DW	Data Write	Writes registers/devices data into the S2T	ST	
MR	Expanded file register data Read	Reads the data in the expansion memory as expanded file register	MR	
MW	Expanded file register data Write	Writes the data in the expansion memory as expanded file register	ST	
SR	System Info 1 Read	Reads S2T's system information 1	SR	
S2	System Info 2 Read	Reads S2T's system information 2	S2	
TR	Diagnostic Message Read	Reads user-defined error information from the S2T	TR	
RT	Clock-calendar Read	Reads clock-calendar data from the S2T	RT	
WT	Clock-calendar Write	Writes clock-calendar data into the S2T	ST	
EC	PLC Control	Changes S2T operation status	ST	
BR	System Info Block Read	Reads S2T's system information, block by block	BR	
RB	Program Block Read	Reads S2T's program block-by-block	RB	
CR	Comment Block Read	Reads S2T's comments block-by-block	CR	
BW	System Information Block Write	Writes S2T's system information block-by-block	ST	
WB	Program Block Write	Writes S2T's program block-by-block	ST	
CW	Comment Block Write	Writes S2T's comments block-by-block	ST	

For details of the T-series computer link protocol, refer to the separate manual "**T-series Computer Link Operation Manual**".

1.4 Free ASCII mode

1.4.1 Free ASCII communication function

The free ASCII mode is used to connect between the S2T and various serial ASCII devices, such as a micro computer, bar code reader, printer, display, etc.

By using this mode, the S2T can work as a communication master. Therefore, the S2T can communicate with other PLCs using the computer link protocol, and can control variable speed drives (such as Toshiba's VF-S7) using its communication protocol.

In this mode, user defined ASCII messages can be transmitted and/or received through the serial port of the S2T, link port (RS-485).

The ASCII message (one set of transmission characters) means a string of ASCII characters which is ended by specified trailing code. The default setting of the trailing code is CR (carriage return code = H0D).

Applicable message format (default trailing code):



N: message length = 512 bytes max.

In other words, the S2T cannot be used for the data communication in which the transmission message is ended by two or more types of trailing code.

NOTE

The Free ASCII mode works as half-duplex communication system.
Therefore, simultaneous operation of transmitting and receiving is not possible.

In the free ASCII mode, communication (message transmitting and receiving) is controlled by S2T's user program.

The expanded transfer (XFER) instruction is used for transmitting and receiving messages.

Transmitting:

To transmit, the user prepares the message in the S2T registers in the format of ASCII character. The message must be ended by a specified trailing code. Then executes the XFER instruction to start transmission.

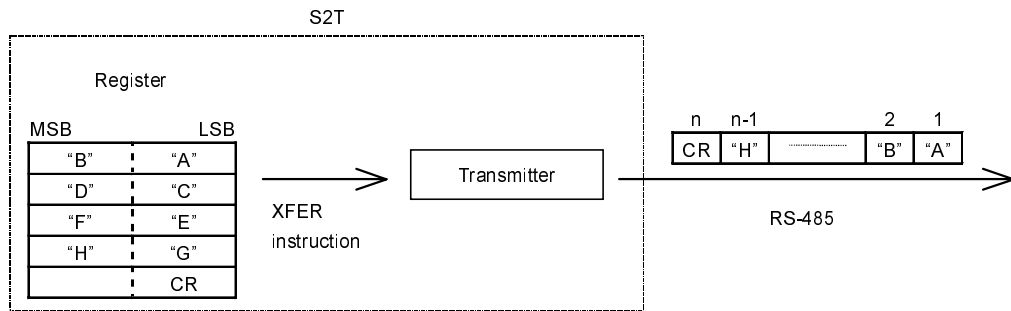

Receiving:

When a message is received, it is stored in the receive buffer. Then, by using the XFER instruction, the message is read and stored in the designated S2T registers in the format of ASCII character.

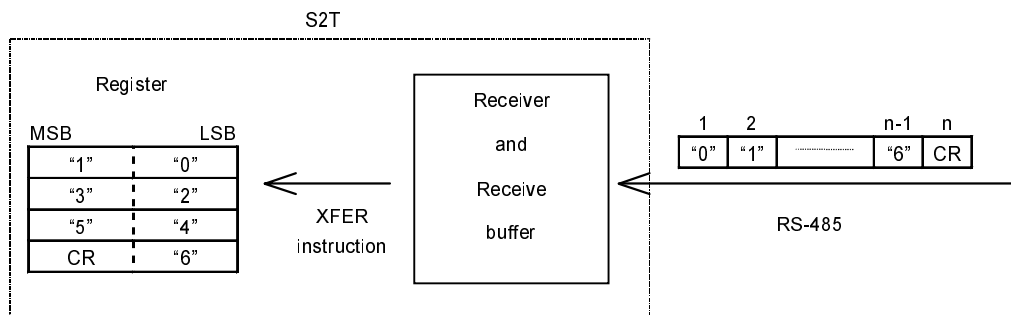

The S2T supports the hexadecimal to ASCII conversion (HTOA) instruction and the ASCII to hexadecimal conversion (ATOH) instruction. These instructions are useful to handle ASCII characters. Refer to section 1.4.9.

1

1.4.2 System configuration

The following figure shows the system configuration using free ASCII communication function.

The S2T is connected to the serial ASCII device(s) through RS-485.

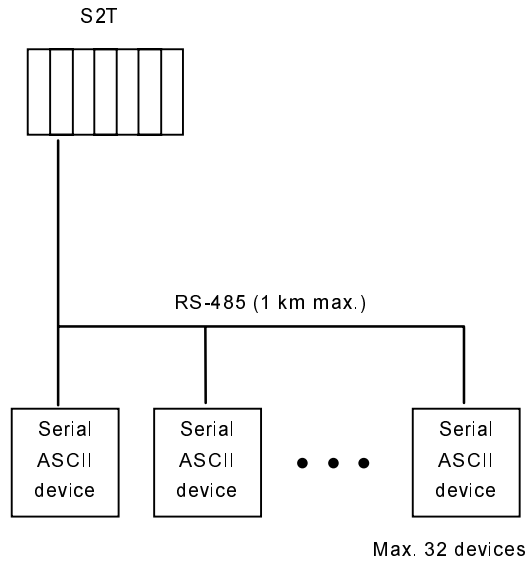

1

4or2 wire system selecting function (RS-485)

Either 4-wire system control or 2-wire system control can be selected in order to connect various serial ASCII device(s) by using the following special function device.

S2T resister	Name	Function
S688	RS-485 Wiring configuration	OFF : 4-wire system ON : 2-wire system(This function is available when selecting 9600 or 19200bps.)

1.4.3 Setup procedure

The following chart shows the setup procedure of the free ASCII mode.

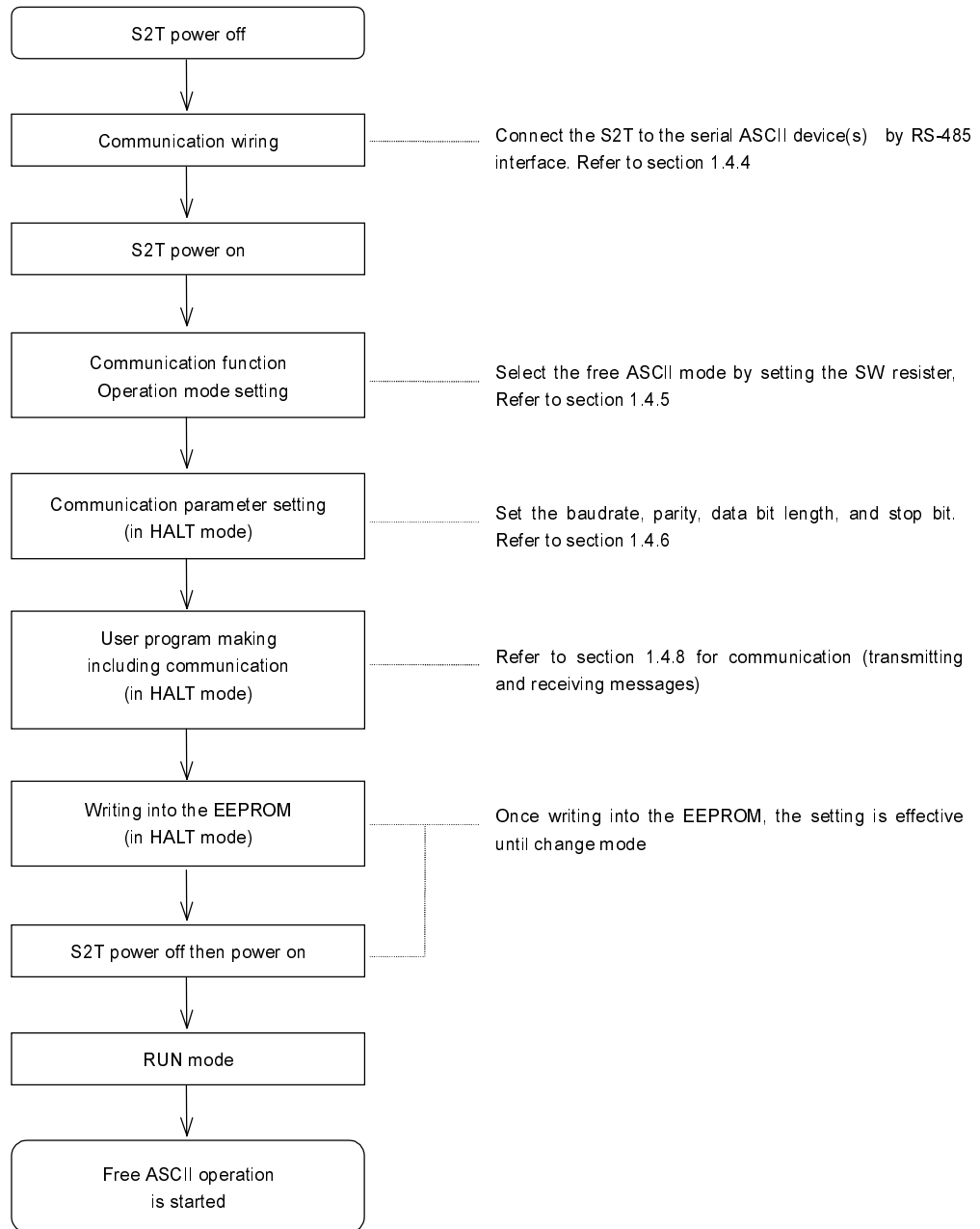

1

1.4.4 RS-485 cable connection

Cable connection examples show as below.

- Use shielded twisted-pair cable for data communication suited to RS-485 standard. The cable shield should be connected to single-point ground.

One to one configuration : 4-wire system

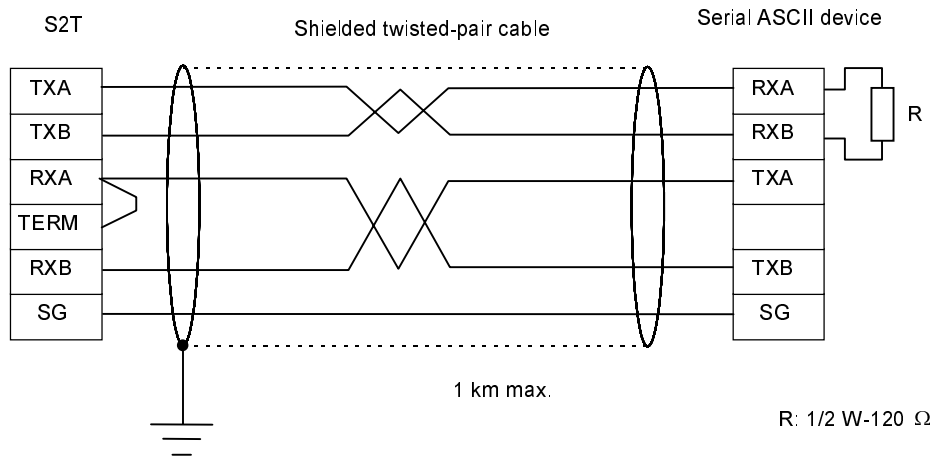

1

- S2T, removable terminal block is provided for cable connection.
- Short between RXA and TERM for termination at the S2T.
- Connect termination resistor 1/2 W - 120 Ω between RXA and RXB at the serial ASCII device.

One to one configuration : 2-wire system

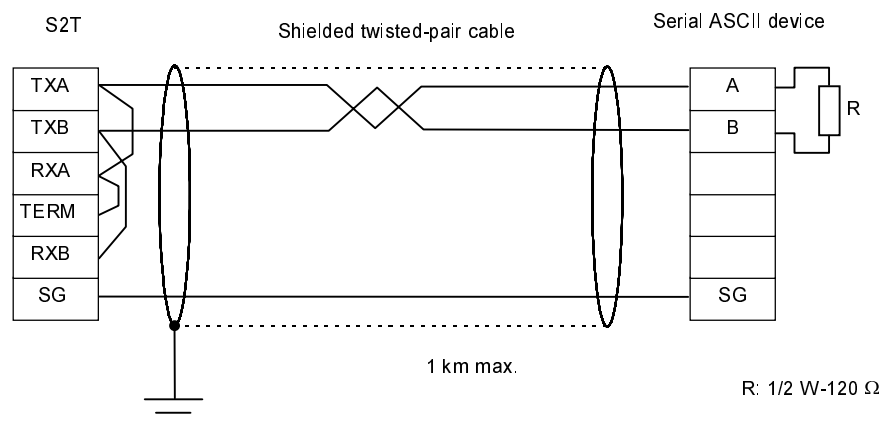

- On the S2T, removable terminal block is provided for cable connection.
- Short between RXA and TERM for termination at the S2T.
- Connect termination resistor 1/2 W - 120 Ω between RXA and RXB at the serial ASCII device.

One to N configuration : 4-wire system

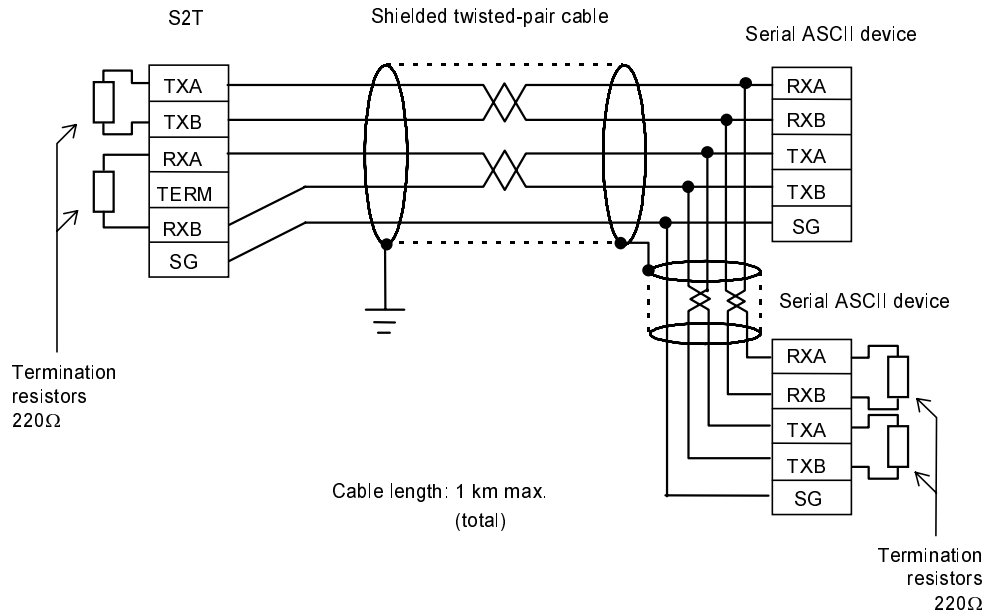

- On the S2T, removable terminal block is provided for cable connection.
- Connect termination resistor 1/2 W - 220 Ω between RXA and RXB, and between TXA and TXB at the both terminal stations.

1.4.5 Mode setting

The operation mode of the S2T's link port is selected by the special resistor provided on the S2T CPU module.

The operation mode is internally set at the timing of power-up. Setting changes while power on is not effective.

To select the computer link mode, the special resistor SW069 set to "2" . (SW069=2)
At the factory, the computer link mode is selected.

S2T resistor	Name	Function
SW069	link port operation mode	0: computer link mode 2: Free ASCII mode

1.4.6 Communication parameter setting

The communication parameter is set by writing it into the system information memory of the S2T.

Turn the S2T to HALT mode, then set the communication parameter in the system information.

(T-PDS screen example)

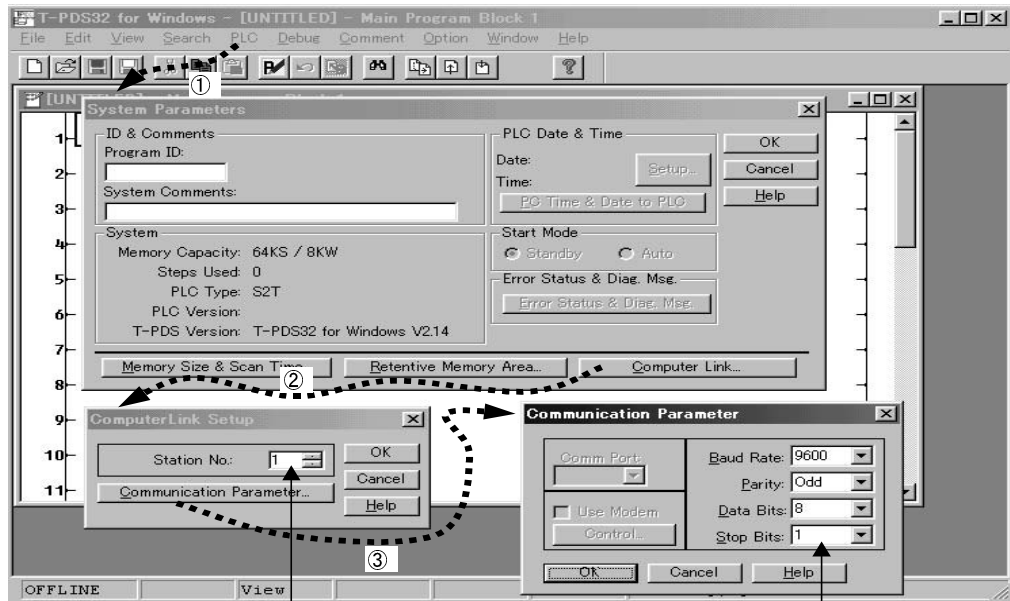

Set baudrate, parity, data bit length, and stop bit.
Station number is ignored.

After the communication parameter setting, write it into the S2T's built-in EEPROM before turning off power.

1.4.7 Message format

The transmission message is composed by ASCII characters and a specified trailing code. The default setting of the trailing code is CR (carriage return code = H0D).

Refer to section 1.4.8 for setting the trailing code other than CR.

The maximum length of a message is 512 bytes. An example of the message is shown below.

1	2	3	4	5	6	7	8	9
"0"	"1"	"2"	"A"	"B"	"7"	"8"	"9"	CR

In the above figure, "x" means an ASCII character. For example, "0" is H30.

The number (1 to 9) shown on each character means the order of transmitting or receiving.

When the above message is received or transmitted, the data arrangements in the S2T registers are as follows.

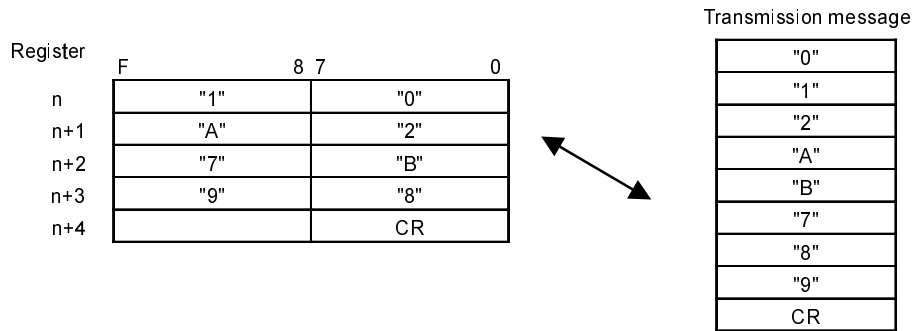

The message length is 1 byte, only trailing code, then receive operation ignore the message.

1

1.4.8 Programming

(1) Changing the trailing code

The default setting of the trailing code is CR (carriage return code = H0D).

The trailing code can be changed by writing the desired code into SW068 at the first scan.

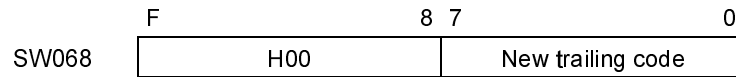

Sample program:

(Sub-program 1)

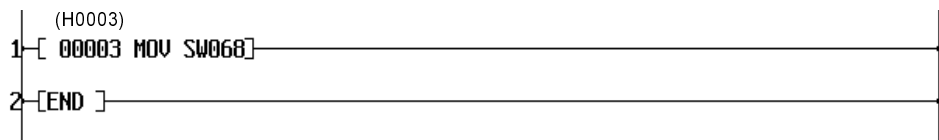

The above program is an example to change the trailing code to H03. The new trailing code H0003 is written into SW068 in the sub-program 1 (initial program).

(2) Data receive operation

When a message is received, it is stored in the receive buffer. The receive buffer is a temporally memory, which has 512 bytes capacity. The expanded transfer (XFER) instruction is used to read the message from the receive buffer and to store it into user registers.

XFER instruction (message receive):

Input —[A XFER B → C]— Output

Operand A: Source

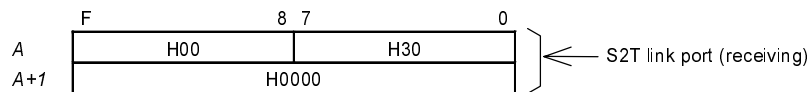

Operand B: Parameter

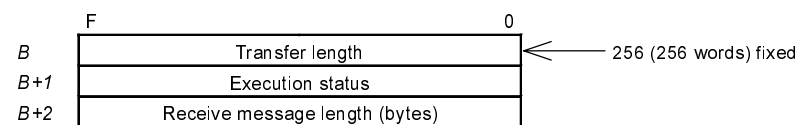

Operand C: Destination register

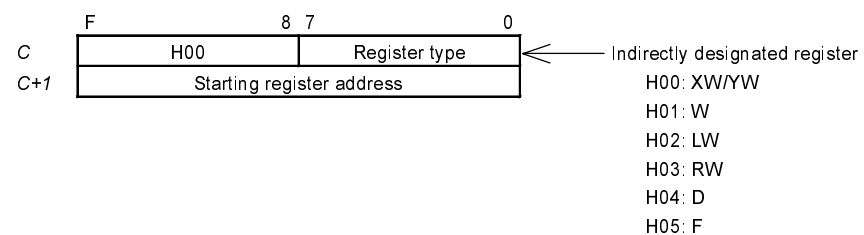

Operation:

When the input condition of the XFER instruction comes ON, the read operation is started. The execution status is monitored by B+1 as follows.

B+1 (Execution status): H0000 ... Normal complete

H0001 ... Communication error (parity error, framing error)

H0002 ... Message length over (more than 512 bytes)

H0003 ... Receive buffer over flow

H0004 ... Receive time-out (see below)

The receive time-out is detected when the time from the starting character to the trailing code exceeds the following time.

Long scan cycle or short receive message, low baudrate avoid the receive time-out.

Baudrate	Time-out setting
300, 600, 1200 bps	30 seconds
2400 bps	15 seconds
4800 bps	7 seconds
9600 bps	3 seconds
19200 bps	1.5 seconds

Sample program:

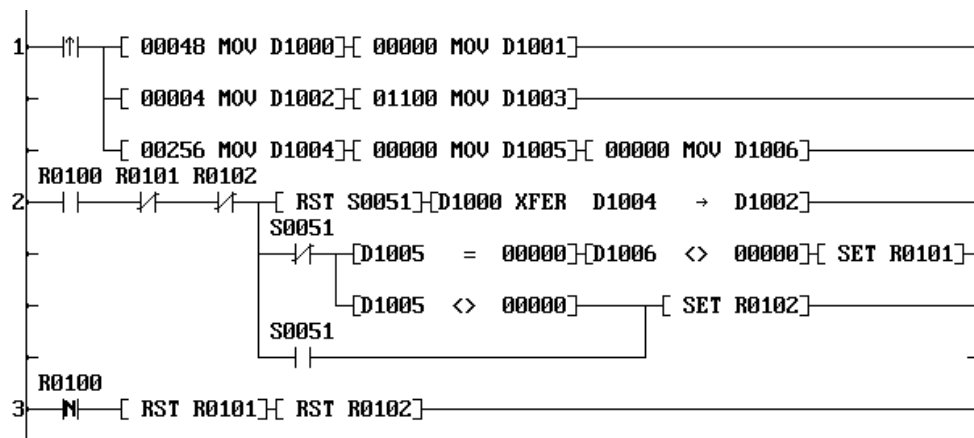

Rung 1: Sets the parameters for the XFER instruction.
The registers of 256 words starting with D1100 are reserved to store the received message.

Rung 2: When R0100 is set to ON, the read operation is started.
If the operation is completed normally, the received message is stored in D1100 and after, and R0101 is set to ON.
If the message could not be received normally by some error, R0102 is set to ON.

Rung 3: When R0100 is reset to OFF, the result status (R0101 and R0102) are reset to OFF.

When using the above sample program as a part of entire application program, set R0100 to ON in the main processing part at first. When a message is received, R0101 (at normal) or R0102 (at error) comes ON. Then reset R0100 and carry out necessary processing for the received message. When the result status shows normal complete (R0101 is ON), the received message has been stored in D1100 and after.

When it becomes ready to receive the next message, set R0100 to ON again.

(3) Data send operation

The expanded transfer (XFER) instruction is used to send the message through the optional communication card.

XFER instruction (message send):

Input —[A XFER B → C]— Output

Operand A: Source register

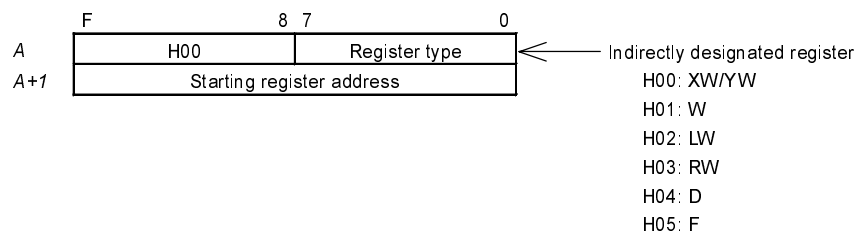

Operand B: Parameter

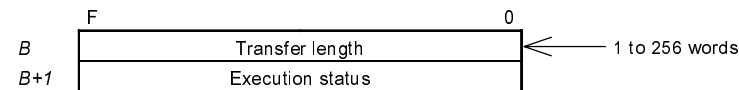

Operand C: Destination

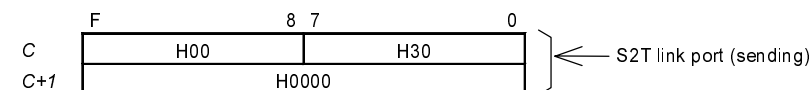

Operation:

When the input condition of the XFER instruction comes ON, the message prepared in the registers starting with A is transmitted.

The execution status is monitored by B+1 as follows.

- B+1 (Execution status): H0000 ... Normal complete
- H0001 ... During transmitting the message
- H0002 ... Communication busy (other receiving or transmitting routine is under executing)
- H0003 ... During the reset operation
- H0004 ... Send time-out (see below)
- H0005 ... Send message length error (no trailing code in the source table)

The send time-out is detected when the time from the starting character to the trailing code exceeds the following time.

Long scan time or short send message, low baudrate avoid the send time-out.

Baudrate	Time-out setting
300, 600, 1200 bps	30 seconds
2400 bps	15 seconds
4800 bps	7 seconds
9600 bps	3 seconds
19200 bps	1.5 seconds

Sample program:

1

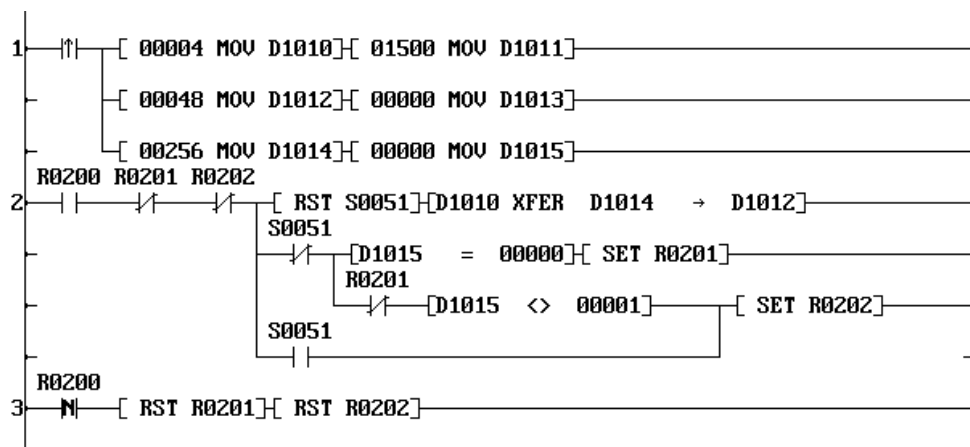

Rung 1: Sets the parameters for the XFER instruction.
The registers of 256 words starting with D1500 are reserved to store the transmitting message.

Rung 2: When R0200 is set to ON, the message stored in the D1500 and after are transmitted.
If the operation is completed normally, R0201 is set to ON.
If some error has occurred during the operation, R0202 is set to ON.

Rung 3: When R0200 is reset to OFF, the result status (R0201 and R0202) are reset to OFF.

When using the above sample program as a part of entire application program, write the transmitting message (including the trailing code) in D1500 and after, and set R0200 to ON in the main processing part. By this operation, message transmitting is started. When the message transmitting is completed, R0201 (at normal) or R0202 (at error) comes ON. Confirm these result status and reset R0200 to OFF. While a message is transmitting, do not change the contents of the transmitting message which has been set in D1500 and after.

(4) Reset operation

By setting S068F to ON, resetting the free ASCII mode operation is available.

During the reset, the following re-initialization is processed.

- Initializes the serial port (RS-485)
- Initializes the receive buffer and the receive error information
- Resets the trailing code based on the data of lower byte of SW068

When the reset operation is completed, S068F is automatically reset to OFF.

The free ASCII mode operation should be re-started after confirming S068F is returned to OFF.

NOTE

If S068F is set to ON during a message receiving, the reset operation is started after the message receiving is finished.

1.4.9 Related instruction

(1) Expanded data transfer (XFER)

FUN 236	XFER	Expanded data transfer
---------	------	------------------------

Expression

Input —[A XFER B → C]— Output

Function

When the input is ON, data block transfer is performed between the source which is indirectly designated by A and A+1 and the destination which is indirectly designated by C and C+1. The transfer size (number of words) is designated by B.

The transfer size is 1 to 256 words. (except for writing into EEPROM)

Data transfer between the following objects are available.

- CPU register ↔ CPU register
- CPU register ↔ Expanded F register (S2T's internal memory)
- CPU register ↔ TOSLINE-S20 (here called S20, for S2T)/
TOSLINE-S20LP(here called S20LP, for S2T)
- CPU register ↔ EEPROM (D register)
- CPU register ↔ S2T link port

Execution condition

Input	Operation	Output	ERF
OFF	No execution	OFF	-
ON	Normal execution	ON	-
	When error is occurred (see Note)	ON	Set

Operand

	Name	Device										Register													Con-stant	Index					
		X	Y	S	L	R	Z	T	C	I	O	X	Y	S	L	R	W	T	C	D	F	I	O	I			J	K			
A	Source parameter											√	√	√	√	√	√	√	√	√											√
B	Transfer size											√	√	√	√	√	√	√	√	√											√
C	Destination parameter												√	√	√	√	√	√	√	√											√



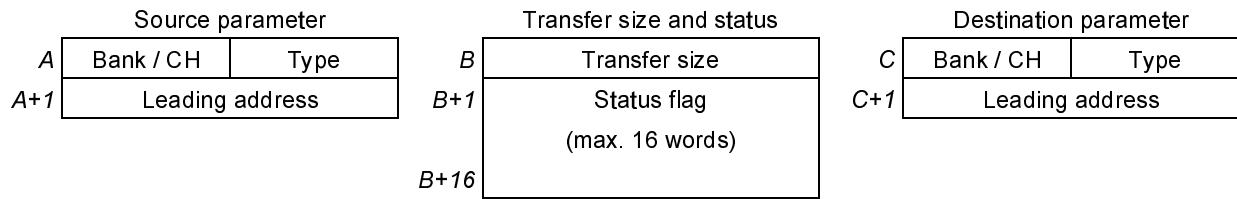

- Refer to the following table for contents of each designation.
- The status flag is created when S20 is designated as transfer source or S2T is designated as source/destination.

Transfer parameter table

Transfer object	Bank / CH	TYPE	Leading address	Transfer size	Status flag
CPU register	XW/YW register	0	H00 0 to 511 (T3H/S2T) 0 to 255 (T3) 0 to 63 (T2/T2E)	1 to 256 (T3H/T3/S2T) 1 to 64 (T2/T2E/T2N)	None
	W register	0	H01 0 to 2047 (T3H/T2N/S2T) 0 to 1023(T3/T2/T2E)	1 to 256	None
	LW register	0	H02 0 to 255 (T3H/T3/T2/T2E/T2N/S2T)	1 to 256	None
	RW register	0	H03 0 to 999 (T3H/S2T) 0 to 511 (T3) 0 to 255 (T2N) 0 to 127 (T2/T2E) 0 to 63 (T1)	1 to 256 (T3H/T3/S2T) 1 to 128 (T2/T2E/T2N) 1 to 64 (T1)	None
	D register	0	H04 0 to 8191 (T3H/T3/T2N/S2T) 0 to 4095 (T2/T2E) 0 to 1023 (T1)	1 to 256	None
	F register	0	H05 0 to 32767 (T3H/S2T) 0 to 8191 (T3) 0 to 1023 (T2/T2E/T2N)	1 to 256	None
Expanded F register (IC memory card)	1 to 15 (T3H/T3/T2)	H05	0 to 8191	1 to 256	None
	1 or 2 (T3H)	H06	0 to 65535 (Bank 1) 0 to 57343 (Bank 2)	1 to 256	None
Expanded F register (T2E/S2T internal memory) ^{*4}	1 to 3 (T2E) 1 to 15 (S2T)	H05	0 to 8191	1 to 256	None
	1 to 8 (S2T)	H06	0 to 65535 (Bank 1 to 7) 0 to 57343 (Bank 8)	1 to 256	None
TOSLINE-S20 scan memory	1 or 2 (T3H/T3/S2T) 1 (T2/T2E)	H10	0 to 1023 (S20)	1 to 256	Yes ^{*1}
TOSLINE-S20LP scan memory	1 or 2 (T3H/S2T) 1 (T2N)	H10	0 to 4095 (S20LP)	1 to 256	Yes ^{*1}
EEPROM (D register)	0	H20	0 to 8191 (T3H/T3/S2T) 0 to 4095 (T2/T2E/T2N) 0 to 511 (T1)	Source (read): 1 to 256 ----- Destination (write): 1 to 128 (T3H/S2T) 1 to 64 (T3) 1 to 32 (T2/T2E/T2N) 1 to 16 (T1)	None
T2E communication card / T2N / S2T link port	0	H30	0	1 to 256 ^{*2}	Yes ^{*3}
Global variable	0 to 7 (S2T)	H51	0 to 16383 (TC-net) 0 to 32767 (C2)	1 to 256	None

- *1) When S20 is transfer source, the scan healthy map is created. (max. 16 words)
In case of S20LP, no status flag is added.
- *2) When the link port is transfer source (receiving), the transfer size must be 256 (fixed).
- *3) When the link port is transfer source (receiving), 2 words of status flag is added.
When it is destination (transmitting), 1 word of status flag is added.
- *4) PU672T has the expansion memory, and use 512k words expanded file resister.
PU662T don't have the expansion memory, so this function can't be used.

1

CPU register ↔ S2T link port

<Receiving>

Operation:

When the instruction input is ON, one set of message (from start character to the trailing code) which is received by the link port is read from the receive buffer, and stored in the CPU registers. The transfer size is fixed to 256 words. The execution status and the message length (in bytes) are stored in the status flag.

The instruction input must be kept ON until the receiving operation is complete.

Example:

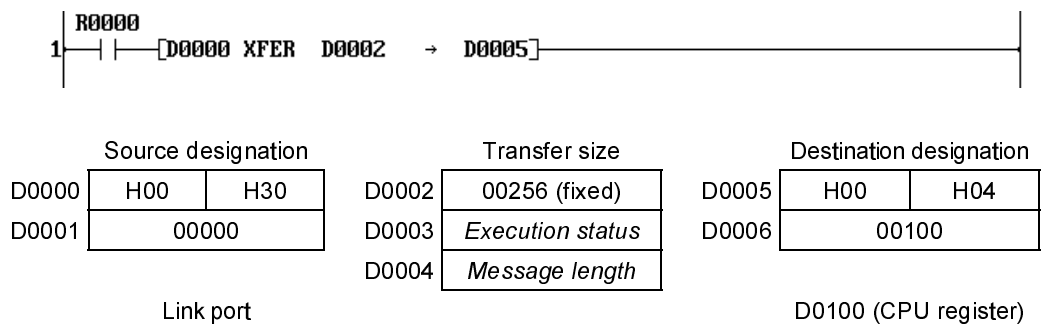

When R0000 is ON, one set of received message is read and stored in D0100 and after.

- Execution status:*
- H0000 ... Normal complete
 - H0001 ... Communication error (parity error, framing error)
 - H0002 ... Message length over (more than 512 bytes)
 - H0003 ... Receive buffer over flow
 - H0004 ... Receive time-out (from start character to the trailing code)

Baudrate	Time-out setting
300, 600, 1200 bps	30 seconds
2400 bps	15 seconds
4800 bps	7 seconds
9600 bps	3 seconds
19200 bps	1.5 seconds

Message length: 0No receive message
1 to 512 ... Message length in bytes

Remarks:

The instruction error flag (S0051) comes ON in the following cases. (no operation)

- The leading address for the link port designation is other than 0.
- Transfer size is other than 256.
- Mode setting of the link port is not the free ASCII mode.
- This instruction is programmed in the sub-program #1.

<Transmitting>

Operation:

When the instruction input is ON, one set of message which is stored in the source table (from start character to the trailing code) is transmitted through the link port. The execution status is stored in the status flag.

The instruction input must be kept ON until the transmitting operation is complete.

Example:

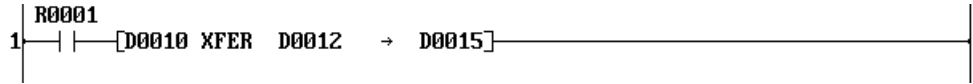

Source designation		Transfer size	Destination designation	
D0010	H00	D0012	H00	H30
D0011	H04	D0013	H30	
	00500		00000	
			00000	

D0500 (CPU register)

Link port

When R0001 is ON, one set of message (ended by the trailing code) stored in the range of D0500 to D0511 (12 words) is transmitted through the link port.

- Execution status:*
- H0000 ... Normal complete
 - H0001 ... During transmitting the message
 - H0002 ... Communication busy (other receiving/transmitting routine is executing)
 - H0003 ... During the reset operation
 - H0004 ... Send time-out (from start character to the trailing code)
 - H0005 ... Send message length error (no trailing code in the source table)

Baudrate	Time-out setting
300, 600, 1200 bps	30 seconds
2400 bps	15 seconds
4800 bps	7 seconds
9600 bps	3 seconds
19200 bps	1.5 seconds

Remarks:

The instruction error flag (S0051) comes ON in the following cases. (no operation)

- The leading address for the link port designation is other than 0.
- Transfer size is out of the range of 1 to 256.
- Mode setting of the link port is not the free ASCII mode.
- This instruction is programmed in the sub-program #1.

(2) HEX to ASCII conversion (HTOA)

FUN 62	HTOA	HEX to ASCII conversion
--------	------	-------------------------

Expression

Input —[A HTOA (n) B]— Output

Function

When the input is ON, the hexadecimal data of *n* registers starting with *A* is converted to the ASCII characters and stored in *B* and after.

The uppermost digit of source *A* is stored in lower byte of destination *B*, and followed in this order.

The allowable range of *n* is 1 to 32.

When index or constant value is set as source *A*., this function can be performed under the condition that *n* is equal to 1. If *n* is more than 1, a boundary error is occurred.

1

Execution condition

Input	Operation	Output
OFF	No execution	OFF
ON	Normal execution	ON

Operand

	Name	Device										Register											Constant	Index				
		X	Y	S	L	R	Z	T	C	I	O	X	Y	S	L	R	W	T	C	D	F	I			O	I	J	K
A	Source											√	√	√	√	√	√	√	√	√	√	√		√	√	√	√	
<i>n</i>	Size																											1 - 32
B	Destination												√	√	√	√	√	√	√	√	√		√					√

Example

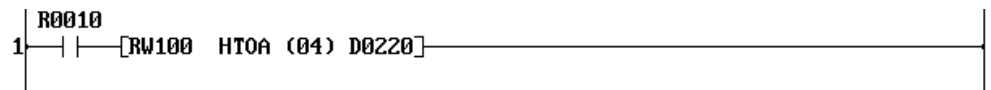

When R0010 is ON, 4 words data of RW100 to RW103 are converted into ASCII characters, and stored in 8 words registers starting with D0220.

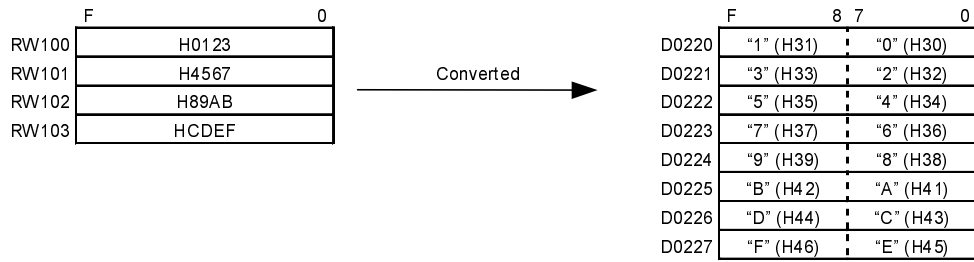

(3) ASCII to HEX conversion (ATOH)

FUN 66	ATOH	ASCII to HEX conversion
--------	------	-------------------------

Expression

Input —[A ATOH (n) B]— Output

Function

When the input is ON, the ASCII characters stored in *n* registers starting with *A* is converted to the hexadecimal data and stored in *B* and after.

The lower byte of source *A* is stored as uppermost digit of destination *B*, and followed in this order.

The allowable ASCII character in the source table is "0" (H30) to "9" (H39) and "A" (H41) to "F" (H46).

The allowable range of *n* is 1 to 64.

When index or constant value is set as source *A*., this function can be performed under the condition that *n* is equal to 1. If *n* is more than 1, a boundary error is occurred.

Execution condition

Input	Operation	Output	ERF
OFF	No execution	OFF	-
ON	Normal execution	ON	-
	Conversion data error (no execution)	OFF	ON

Operand

	Name	Device										Register										Constant	Index				
		X	Y	S	L	R	Z	T	C	I	O	X	Y	S	L	R	W	T	C	D	F			I	O	I	J
<i>A</i>	Source											√	√	√	√	√	√	√	√	√	√					√	√
<i>n</i>	Size																									1 - 64	
<i>B</i>	Destination											√	√	√	√	√	√	√	√	√	√	√					√

Example

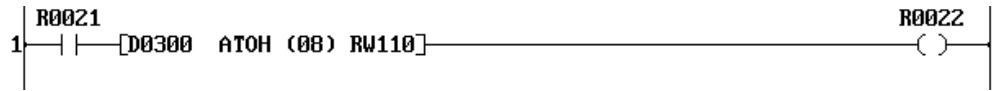

When R0021 is ON, the ASCII characters stored in 8 words of D0300 to D0307 are converted into hexadecimal data, and stored in 4 words registers starting with RW110.

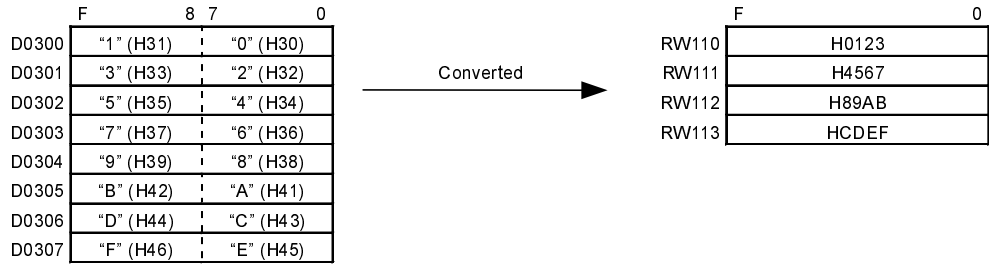

If the source table (D0300 to D0307) contains invalid characters (other than "0" to "F"), the instruction is not executed and the output (R0022) stays OFF.

If the word number of conversion is odd, the lower 2 digits of last data on the destination table is unknown.

Therefore set even value to the word number of conversion.

1.4.10 Sample programs

A. Variable speed drive (Toshiba's VF-S7) control

A sample program for the S2T to control the variable speed drive, VF-S7, is shown here.

For details of the serial communication function of the VF-S7, read the separate manual "VF-S7 Serial Communication Function".

(1) Link port setting

a) Mode setting of the Link port (S2T):

Select the free ASCII mode by setting the SW069 to "2"

b) Communication parameter setting:

Set the S2T's communication parameters (baudrate, data bit length, parity and stop bit length) to be matched the VF-S7's setting.

The VF-S7's setting at factory shipment is as follows.

Baudrate: 9600 bps (changeable)

Data bits: 8 bits (fixed)

Parity: Odd (changeable)

The S2T's stop bit length should be set to 1 bit.

c) Communication time-out setting of VF-S7:

To let trip the VF-S7 at the case of communication error, enable the time-out function of the VF-S7. To do this, set the monitor time on the VF-S7's parameter F803.

In this sample program, the VF-S7's operation (start and stop) is controlled through the serial communication. However, for actual application, it is recommended to use the terminal inputs for the signals F (forward) and R (reverse) even if the frequency is controlled through the serial communication.

(2) Communication commands used in this sample program

In this sample program, the following commands (function numbers) are used. The VF-S7's station number is assumed as 01.

FE01	Operation status (read)
FA00	Control command (write) – forward / reverse / stop / reset
FA01	Operation frequency (write)

(3) S2T sample program

In this sample program, the following devices/registers are assigned.

- D0015: Operation frequency (0 to 6000, 0.01 Hz increments)
- R0000: Forward command (ON for start / OFF for stop)
- R0001: Reverse command (ON for start / OFF for stop)
- R0019: Status (forward: OFF / reverse: ON)
- R001A: Status (stop: OFF / run: ON)

```

MAIN PROGRAM          BLOCK 1

1  -|^| ----- [MCS ] Initialize
2  [ 00004 MOV D0000][ 00010 MOV D0001][ 00048 MOV D0002][ 00000 MOV D0003] Parameter setting for
   XFER (send)
3  [ 00007 MOV D0004][ 00000 MOV D0005] -----
4  [ 00004 MOV D0010][ 00040 MOV D0011] ----- Parameter setting for
   XFER (receive)
5  [ 00256 MOV D0012][ 00000 MOV D0013][ 00000 MOV D0014] -----
6  ----- [MCR ]
7  [D0015 <> D0016][D0015 MOV D0016] ----- R0002 Change detect of
   ( )-- frequency designation
   (D0015)
8  R0000 Send message create
   -|P|--['(01PFA00C400) ' ASC D0020]-----+ (Station 01)
   R0001 Command (FA00)
   -|P|--['(01PFA00C600) ' ASC D0020]-----+
   R0000 Following commands are
   -|N|+['(01PFA00C000) ' ASC D0020]-----+ used
   R0001| "C400": Forward
   -|N|+| "C600": Reverse
   R0003| "C000": Stop
   -|P|+['(01PFA00E000) ' ASC D0020]-----+ "E000": Reset
   R000F|
   -|P|+|
   R0002 Operation frequency
   -| |+['(01PFA010000) ' ASC D0020]-----+ (FA01)
   +[D0015 HTOA (01) D0024]-----+ Converts hex data of
   D0015 into ASCII
[ ]----[H0D00 OR D0026 -> D0026][ SET R000D][ 00020 MOV D0017] ----- Adds trailing code (H0D)

```



1

9	<pre> R000D T.000 - / --- / ---[00060 TON T000] ['(01RFE01) ' ASC D0030] ----- [] </pre>	<p>Message for Status read</p> <p>Address FE01 read</p>
	<pre> []----[H0D00 OR D0034 -> D0034][SET R000E][00030 MOV D0017] ----- </pre>	<p>Adds trailing code (H0D)</p>
10	<pre> R000E R000D - / --- --- ^ ---+ [D0017 MOV D0001][SET R000A] ----- T.000 - P -----+ </pre>	<p>Message send timing create</p>
11	<pre> R000A - ---+ [D0000 XFER D0004 -> D0002] ----- + [D0005 = 00001]- v --- [RST R000A] ----- </pre>	<p>Message send</p>
12	<pre> R000A - / ---+ [D0002 XFER D0012 -> D0010] ----- +S0051 +-/ --- [D0014 <> 00000] ----- R0009 ()-- </pre>	<p>Message receive</p>
13	<pre> R0009 R000D - --- ---[D0020 = D0040][D0022 = D0042][D0023 = D0043] ----- [] []----[D0024 = D0044][D0025 = D0045][RST R000D][RST R0003] ----- </pre>	<p>Received message check for Command</p>
14	<pre> R0009 R000E - --- ---[D0030 = D0040][D0032 = D0042][D0033 = D0043] ----- [] []----[RST R000E][D0044 ATOH (02) RW001][D0041 AND HFF00 -> D0039] </pre>	<p>Received message check for Status read</p>
15	<pre> R000D - ---+ [00300 TON T001][RST R000D][RST R000E][RST R000A]-----+-() R000F + R000E R000E - --- ---[D0039 = 29184] ----- + </pre>	<p>Timing create for Reset command</p>
16	<pre> R000F - ---[00000 MOV D0015][RST R0000][RST R0001] </pre>	<p>Flags and frequency data clear for Reset command</p>
17	<pre> [END] ----- </pre>	

1.5 Units

As mentioned in Section 1.1, the basic unit of the model 2000 is composed of a main base, a power supply module, a S2T CPU module.

The expansion interface is added to the main base depending on I/O modules required.

The expansion interface should be mounted on each base and are connected with expansion cables. Set the unit No. (called unit address) before operating. The unit address is set by a rotary switch in the middle of the expansion interface.

1.5.1 Bases

The base has two kinds of type bases, for dedicated to the basic unit and for expansion unit.

For details of unit configuration, see Section 1.1.3

Table1-5-1 Number of direct I/O module installation

Type	Description	Direct I/O Module	Remarks
BU648E	For basic unit	8	
BU643D	For basic unit	3	
BU668	For expansion unit	8	
BU666	For expansion unit	6	
BU664	For expansion unit	4	

• BU648E

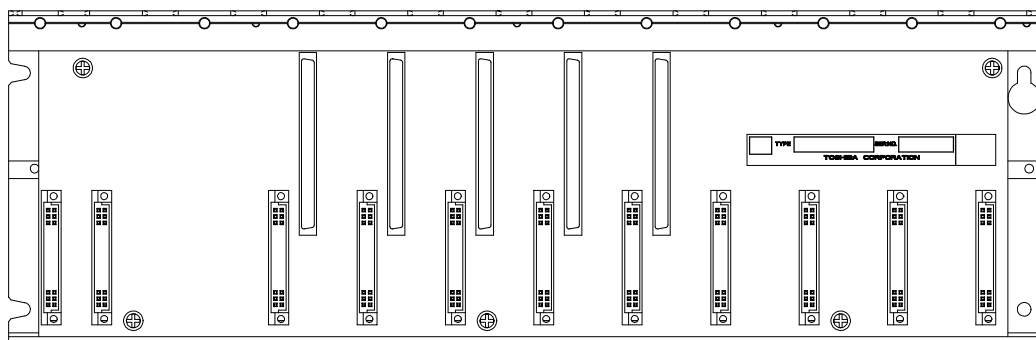

• BU643D

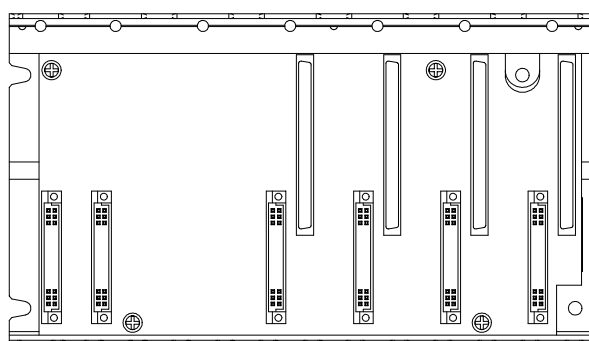

- BU668

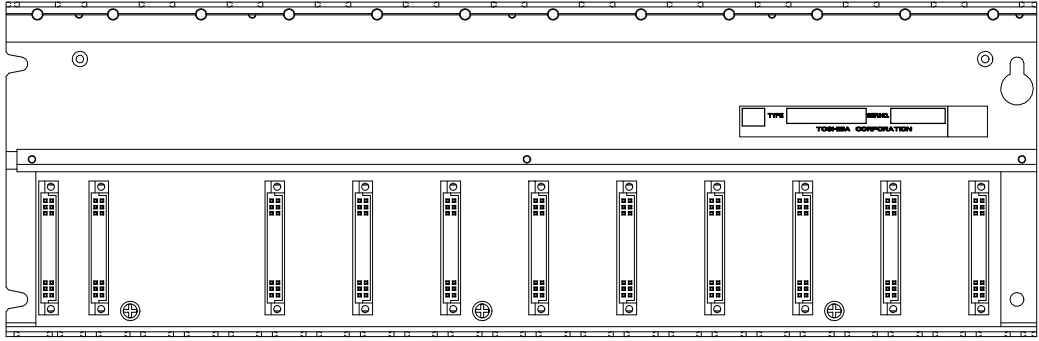

- BU666

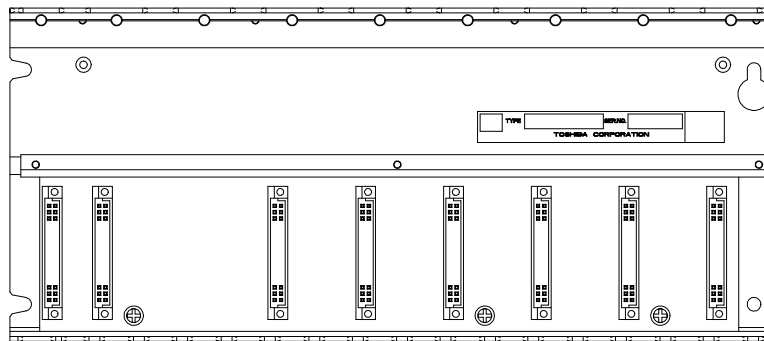

- BU664

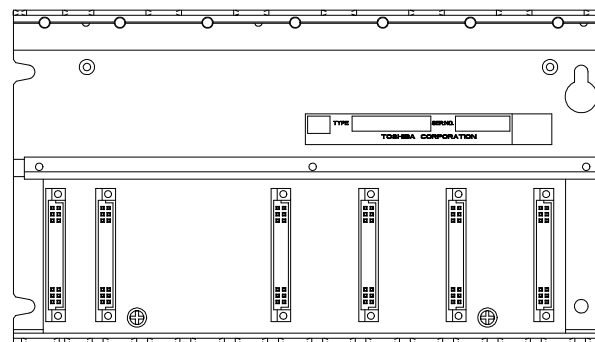

1

NOTE

Use a space module (GSP600*AS) to prevent debris from collecting in the base where no direct I/O modules and station modules are mounted.

1.5.2 Expansion interface

The expansion interface IF661 is mounted on the left side slot of base to expand bases after removing the unit cover. Set the unit No. (called unit address) before operating. The unit address is set by a rotary switch in the middle of the expansion interface removed the cover.

- Setting the unit No.

The rotary switch to set unit address is provided between two expansion connectors. The upper side connector is for input from previous unit and the lower side connector is for output to the next unit.

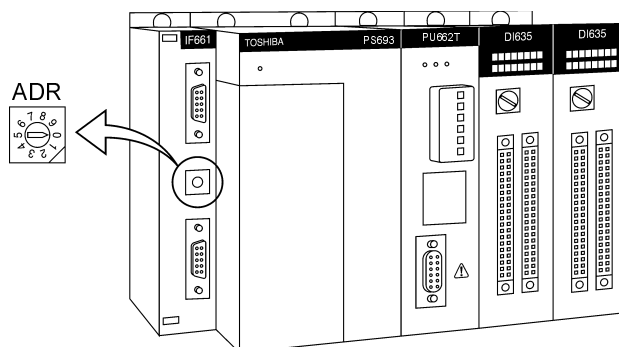

Mounted on	Switch setting	Remarks
Basic unit	0	
Expansion unit	1,2,3	Set in order to 1>2>3, starting from the unit closest to the basic unit.

NOTE

- Switches will be set to 0 at the factory.
- Be careful not to duplicate unit Nos. on units.
- Do not use setting 4 - 9, as these are not for use.

1.5.3 Expansion cables

These are used for connecting the basic unit and the expansion units.

They are available in the following four lengths.

Type	Length	Remarks
CS6R3	30cm	
CS6R5	50cm	
CS6R7	70cm	
CS6*1	1.2m	

NOTE

The maximum cable length between units is 1.2m.
The maximum total cable length is 3.6m.

1.6 Power Supply Module

Power supply modules are mounted on the second slots from the left-end of all bases.

There are two types according the power voltage and total power. Select one as required.

Configure the system, referring to the module current consumption table in the Section 1.18.2, so that the following equation is satisfied.

$$\text{Maximum power consumption} \geq 5V * \text{Total } 5V \text{ current} + 3.3V * \text{Total } 3.3V \text{ current} + 24V * \text{external } 24V \text{ current}$$

1.6.1 Power Supply Module

There are three type modules as follows.

Type	Nominal Input Voltage	Output Rating			Weight (approx.)
		Internal control supply	External power supply	Power consumption	
PS691	AC100-120V AC200-240V (+10%, -15%)	5V-8A, 3.3V-1.0A	None	Less then 43W	650g
PS693	AC100-240V (+10%, -15%)	5V-7A, 3.3V-1.0A	DC24V (± 10%) 0.8A	Less then 35W	600g
PS694		5V-6A, 3.3V-1.0A	None	Less then 35W	600g
PS632	DC24V (+20%, -15%)	5V-7A, 3.3V-1.0A	None	Less then 35W	600g
PS652	DC100/110V (+10%, -15%)	5V-7A, 3.3V-1.0A	None	Less then 35W	600g

1

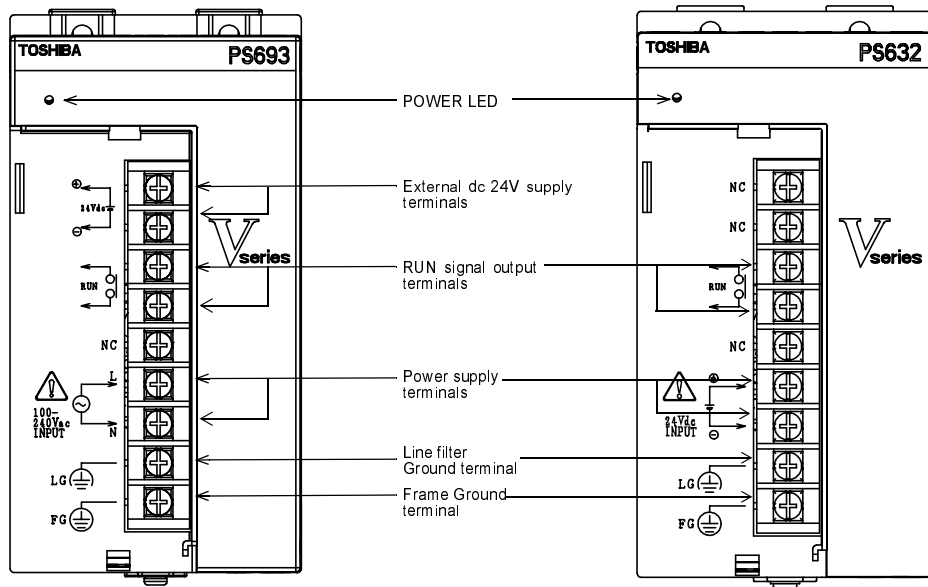

Fig.1-6-1 Power Supply Module front view

CAUTION



Mandatory

Operate the S2T and the related modules which closing the terminal covers. Keep hands away from terminals while power on, to avoid the risk of electrical shock.

This power supply module is dedicated power supply for the S2T and the model 2000. Do not use it by itself for other purposes.

- **Power status LED (POWER)**
The POWER LED is lit while the internal 5Vdc power supply is provided normally.
- **Power Supply Terminals (ac input : L,N / dc input :+, -)**
Connect to the power supply line. (See 4.6 Wiring the power supply)
- **Line Filter Ground Terminal (LG)**
Connected to the power supply lines via capacitors. Grounding terminal.
(See 4.5 Grounding methods)
- **Frame Ground Terminal (FG)**
Connected to the unit base frame. Grounding terminal.
(See 4.5 Grounding methods)
- **RUN Signal Output Terminals (RUN contact)**
This is one built-in a-contact type relay output. When the S2T is in the operating mode (RUN), it is closed.
Error is occurred when any controller mounted on the main base is in the HALT mode or is abnormal, and this contact is opened.

Specification of the RUN contact : 240Vac(+10%)/24Vdc(+20%)-0.2A (Max.)

RUN contact	Operation	Remarks
ON(closed)	All controllers are in the normal operation.	
OFF(opened)	Any controller is in the HALT mode or in the abnormal operation.	It's OFF during initializing

1

NOTE

- *1 Which module controls the RUN contact ?
The only controller modules of station modules can control the RUN contact.
- *2 RUN contact control
User can set the parameter to control the RUN contact operation in order to apply for variety industrial system. The RUN contact isn't operated even if the controller set to no-valid goes to the HALT mode or the abnormal mode.
The parameter is set to be valid in the initial mode.

Table1-6-1 RUN contact operation

	Type	RUN contact control		Setting	Remarks
		valid	no-valid		
Sequence controller	PU***T	○	—	Programmer	
Computer	C2PU**	○	—	User program	
Ethernet	EN6**	—	—		
TC-net	CN6**	—	—		

- :The controller status is related to the RUN contact operation.
- :The controller status is not related to the RUN contact operation.

- External 24Vdc Output Terminals
These terminals can be used to supply 24Vdc power to external devices such as sensors or relay output modules.

1.6.2 Power capacity consideration

The table below shows the maximum current consumption of each base/module. When configuring the units, confirm that the total current consumption is within the power supply output capacity, so that the following equation is satisfied.

$\begin{aligned} \text{Maximum power consumption} &\geq 5\text{Vdc} \times \text{Total 5V current} + 3.3\text{Vdc} \times \text{Total 3.3V current} \\ &+ 24\text{V} \times \text{external 24V current} \end{aligned}$

Table1-6-1 Current consumption / Weight Table

Name		Type	Internal current consumption (Max.)		External current consumption (Max.)	Weight (Approx.)
			5Vdc	3.3Vdc		
base		BU648E	100mA	—	—	900g
		BU643D	100mA	—	—	500g
		BU668	—	—	—	900g
		BU666	—	—	—	600g
		BU664	—	—	—	450g
Expansion interface	For basic unit	IF661	150mA	—	—	150g
	For expansion unit		500mA	—	—	
S2T CPU	32KS	PU662T	1200mA	200mA	—	350g
	64KS	PU672T	1200mA	200mA	—	350g
C2 CPU	Hard Disk	C2PU35	3000mA	—	—	
TOSLINE -S20	co-axial	SN625	800mA	—	—	350g
	optical	SN626	800mA	—	—	350g
	optical double-loop	SN627	800mA	—	—	350g
Ethernet	10BASE5	EN611	1400mA	200mA	—	350g
	10BASE2	EN631	1400mA	200mA	—	350g
	100BASE-TX, 10BASE-T	EN651	1500mA	—	—	500g
TC-net10	Co-axial	CN611	1000mA	—	—	500g
	Co-axial, dual bus	CN612	1300mA	—	—	350g

Name	Type	Internal current consumption (Max.)		External current consumption (Max.)	Weight (Approx.)
		5Vdc	3.3Vdc		
8-point DC/AC input (12-24V)	DI632D	100mA	—	—	200g
16-point DC/AC input (12-24V)	DI633	15mA	—	—	250g
32-point DC input (24V)	DI634	70mA	—	—	200g
64-point DC input (24V)	DI635	100mA	—	—	250g
64-point DC input (24V) High speed	DI635H	100mA	—	—	250g
16-point DC input (100V)	DI653	100mA	—	—	250g
16-point AC input (100-120V)	IN653	15mA	—	—	300g
16-point AC input (200-240V)	IN663	15mA	—	—	300g
16-point relay output	RO663	50mA	—	24Vdc-80mA	250g
8-point isolated relay output	RO662S	40mA	—	24Vdc-100mA	250g
16-point transistor output	DO633	60mA	—	24Vdc-35mA	300g
32-point transistor output	DO634	150mA	—	—	200g
64-point transistor output	DO635	250mA	—	—	300g
16-point transistor (PNP)	DO633P	60mA	—	—	200g
12-point triac output	AC663	300mA	—	—	300g
Change detect DC input	CD633	200mA	—	—	250g
4ch analog input (8bit) (1-5V)	AD624L	50mA	—	12/24Vdc-70mA	250g
4ch analog input (12bit) (1-5V)	AD624	50mA	—	24Vdc-90mA	300g
4ch analog input (8bit) (0-10V)	AD634L	50mA	—	12/24Vdc-50mA	250g
4ch analog input (12bit) ($\pm 10V$)	AD674	50mA	—	24Vdc-90mA	250g
8ch analog input (16bit) (4-20mA, -10 - +10V)	AD668	300mA	—	120mA	300g
8ch analog input (12bit) (0-5V, 0-20mA)	AD628S	600mA	—	—	350g
8ch analog input (12bit) (-10 - +10V)	AD638S	600mA	—	—	350g
RTD input (Pt100)	RT614	500mA	—	—	300g
TC input (E,J,K)	TC618	300mA	—	120mA	300g
2ch analog output (8bit) (4-20mA/1-5V)	DA622L	70mA	—	24Vdc-90mA	250g
2ch analog output (12bit) (4-20mA/1-5V)	DA622	170mA	—	24Vdc-90mA	250g
2ch analog output (12bit) ($\pm 10V$)	DA672	170mA	—	24Vdc-90mA	250g
4ch analog output (16bit) (4-20mA, 0-20mA, 0-10V, $\pm 10V$)	DA664	230mA	—	DC 24V-240mA	300g
Serial interface	CF611	550mA	—	—	300g
TOSLINE-S20 (co-axial)	SN621	600mA	—	—	350g
TOSLINE-S20 (optical)	SN622	700mA	—	—	300g
TOSLINE-F10 (Master Station)	UN611	600mA	—	—	350g
TOSLINE-F10 (Remote Station)	UN612	600mA	—	—	350g
Devicenet scanner	DN611A	500mA	—	—	500g
FL-net	FL611	650mA	—	—	500g
FL-net	FL612	650mA	—	—	500g
2ch pulse input (dc input)	PI632	500mA	—	—	250g
2ch pulse input (RS422 input)	PI672	650mA	—	—	250g
2axis position control	MC612	700mA	—	24Vdc-200mA	250g
4axis position control	MC614*1	700mA	—	24Vdc-200mA	250g

1

NOTE

- i) The external 24Vdc in the Table are not power supplies for input/output signals. They are the power supplies required for module operation.
- ii) *1 : under development.

1.7 I/O Modules

Various types of direct I/O modules are available for the model 2000, as shown in the following table. Thus, it can respond to a wide variety of applications.

Direct I/O modules can be mounted on any slot in the base, and in any order. (See Section 4.7 for recommended arrangements)

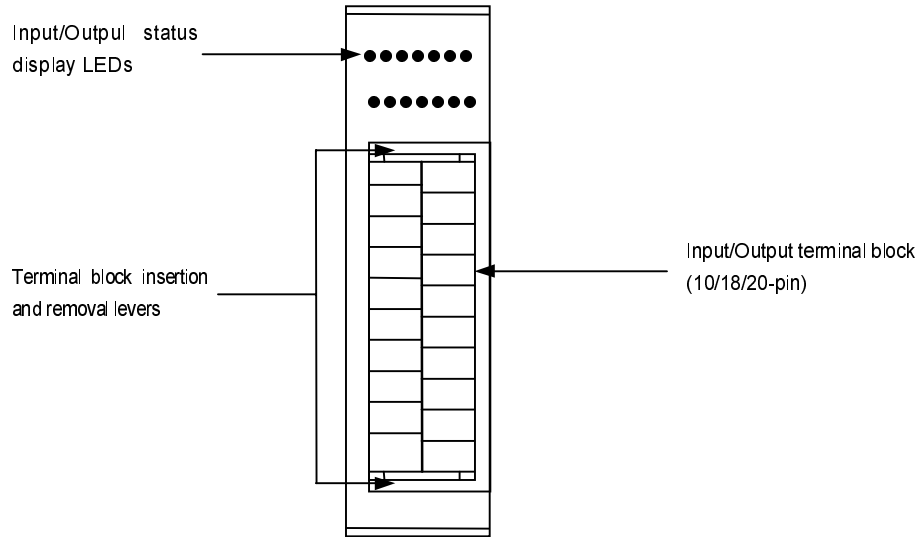

1

Type	Description	Specification
DI632D	DC/AC input	8-point (each point isolated), 12-24Vdc/ac
DI633		16-point (8 points per common), 12-24Vdc/ac
DI634	DC input	32-point (8 points per common), 24Vdc
DI635		64-point (8 points per common), 24Vdc
DI635H		64-point (8 points per common), 24Vdc, High speed
DI653		16-point (each point isolated), 100Vdc
IN653		AC input
IN663		16-point (16 points per common), 200-240Vac
RO663	Relay output	16-point (8 points per common), 240Vac(+10%)/24Vdc(+20%) 2A/point, 4A/4 points common (max.)
RO662S		8-point (each point isolated), 240Vac(+10%)/24Vdc(+20%), 2A/point (max.) 100Vdc (+10%),0.3A/point
DO633	Transistor output	16-point(16 points per common), 5-24Vdc 1A/point, 1.2A/4 points (max.)
DO634		32-point (8 points per common), 5-24Vdc
DO635		64-point (8 points per common), 5-24Vdc
DO633P		16-point (16 points per common), 12-24Vdc, source
AC663	Triac output	12-point (4 points per common), 100-240Vac 0.5A/point, 0.6A/2-element SSR (max.)
CD633	Change detect DC input	16-point (16point per common), 12-24Vdc status change detect, interrupt generation
AD624L	Analog input (8bit)	4-channel (not isolated between channels), 1-5V/4-20mA, 8bit resolution
AD634L		4-channel (not isolated between channels), 0-10V, 8bit resolution
AD624	Analog input (12bit)	4-channel (not isolated between channels), 1-5V/4-20mA, 12bit resolution
AD674		4-channel (not isolated between channels), -10V - +10V, 12bit resolution

Type	Description	Specification
AD668	Analog input (16bit)	8channel (not isolated between channels), 4-20mA, -10 - +10V, 16bit resolution
AD628S	Analog input (12bit)	8channel (isolated between channels), 0-5V, 0-20mA, 12bit resolution
AD638S	Analog input (12bit)	8channel (isolated between channels), -10 - +10V, 12bit resolution
RT614	RTD input	4channel (not isolated between channels), Pt100, 12bit resolution
TC618	TC input	8channel (not isolated between channels), E,J,K, 16bit resolution
DA622L	Analog output (8bit)	2-channel (not isolated between channels), 1-5V/4-20mA, 8bit resolution
DA622	Analog output (12bit)	2-channel (not isolated between channels), 1-5V/4-20mA, 12bit resolution
DA672		2-channel (not isolated between channels), -10 - +10V, 12bit resolution
DA664	Analog output (16bit)	4channel (not isolated between channels), 1-5V, 4-20mA, -10 - +10V, 16bit resolution
CF611	Serial Interface	RS-232C 1port, Common memory 160W×2
PI632	Pulse input	2-channel (A/B two phase with zero marker), 5/12/24Vdc, 100kHz(max.), 24bit counter
PI672		2-channel (A/B two phase with zero marker), RS422, 100kHz(max.), 24bit counter
MC612	2-axis positioning control	2axis, 200kpps(max.), 5-24Vdc, 2 independent axis or 2-axis linear interpolation, position data memory capacity 30 points/ each
MC614	4-axis positioning control	4axis, 1Mpps(max), Line Drive, 4 independent axis or 2-axis liner interpolation/circle interpolation

NOTE

For detailed specifications of each I/O modules, see Section 2.3 I/O Module Specifications. About Analog, communication, other intelligent modules (non-Direct I/O), refer to the each separate manual.

1.8 Network Modules

By applying the following 6 types of network module according to the system requirements, the S2T can configure the flexible and efficient control systems.

- TOSLINE-F10

The Controller to Controller data linkage and remote I/O systems are configured by the TOSLINE-F10 data transmission equipment.

Up to 8 modules model 2000 stations can be mounted on any slots, in the same way as I/O modules.

	UN611/UN612 (High-speed setting)	UN611/UN612 (Long-distance setting)
Cable	twisted -pair cable	
Topology	Bus	
Transmission speed	750kbps	250kbps
Transmission distance	500m	1km
No. of stations	Max. 32 stations	
Transmission capacity	32 words	
Response speed	7ms (when 32 words)	12ms (when 32 words)

- TOSLINE-S20/S20LP

The TOSLINE-S20 is a Local Area Network (LAN) for a factory automation systems. It can achieve high-speed data linkage between the Controllers and communication between industrial computers.

Up to 2 modules model 2000 stations can be mounted on station module slots.

	SN625	SN626
Cable	Co-axial cable	Optical fiber cable
Topology	Bus	
Transmission speed	2Mbps	
Transmission distance	1km	10km (1km between stations)
No. of stations	Max. 64 stations	
Transmission capacity	1024 words W0 - W1023/W1024 - W2047	
Response speed	Min. 5ms in scan transmission	

The TOSLINE-S20LP is a double-loop system using optical fibers and can continue data linkage if any problem is occurred in one loop.

Transmission data capacity is expanded to 4k words.

		SN627
Cable		Optical fiber cable
Topology		Double-Loop
Transmission speed		2Mbps
Transmission Distance	between stations	1km (4km using the optical repeater)
	total	30km
Number of stations		Max. 64 stations/loop
Transmission capacity		4,096words W0000-W2047 (Z/W) and any 2048word registers (using XFER instruction)
Response speed		Min. 5ms in scan transmission

- DeviceNet

The DeviceNet is a field network. It can achieve data linkage between the S2T and any ODVA certified devices. The S2T can use the DeviceNet scanner module.

It is effective for connecting the DeviceNet systems to the S2T.

The model 2000 stations can be mounted on any slots, in the same way as for direct I/O modules.

DN611A			
Cable	Twisted-pair cable		
Topology	Bus		
Transmission speed	125kbps	250kbps	500kbps
Transmission distance	500m	250m	100m
No. of stations	Max. 64 stations		

- FL-net

FL-net is a high-speed data linkage LAN for a factory automation systems.

Up to 4 modules model 2000 stations can be mounted on any slots, in the same way as I/O modules.

FL611/FL612		
Applicable standard	10BASE5	10BASE-T
Topology	Bus	
Transmission speed	10Mbps	
Transmission Distance	2.5km/system 500m/segment	500m/system 100m/segment
Number of stations	Max. 254 stations/bus	
Transmission capacity	8192words + 8192 bit	
Response speed	Min. 50ms /32 stations,2048word	
Communication Function	(1) Scan transmission (2) Message transmission	

- Ethernet

The Ethernet is a standard Local Area Network (LAN) not only for OA but also for factory automation systems.

It can achieve high-speed data linkage between PLCs and communication with higher level computers (workstation/personal computer). The S2T supports T-series computer link function, PLC data link function and socket interface function.

Applicable standard	10BASE5	10BASE2	100BASE-TX/ 10BASE-T
Module	EN611	EN631	EN651
Topology	Bus		
Transmission speed	10Mbps		100Mbps/10Mbps
Transmission cable / cable length	Yellow cable for Ethernet/ 500m max AUI cable/ 15m max	3D-2V /0.5~185m max 5D-2W /185m max	Category 5twisted-pair cable /100m
Media access	CSMA/CD		
No. of nodes	126 nodes maximum per system (different from system)		
No. of repeaters	4 repeaters maximum per system		
Protocol	TCP/UDP/IP		
System configuration	Ethernet modules:4 maximum		
Communication Function	(1) T-series computer link (2) T-series PLC link (3) Socket interface		

1

Chapt.2 Specifications

2

2.1 General Specifications

	Item	Specification	
Environmental conditions	Operating temperature	0 to 55°C	
	Storage temperature	-25 to 70°C	
	Relative humidity	5 to 90%RH	
	Dust density	10mg/m ³ or less	
	Corrosion immunity	No corrosive gases Sulphurous acid gas 0.05ppm or less Hydrogen sulphide 0.01ppm or less	
	Vibration immunity	Conforms to JIS C0040 9.8m/s ² (3 mutually perpendicular axes)	
	Shock immunity	Conforms to JIS C0041 98m/s ² (3 mutually perpendicular axes)	
	Altitude	Up to 2000m	
	Insulation resistance	50MΩ or greater (between power terminals and ground terminals)	
	Withstand voltage	1500Vac - 1minute *1	
	Construction	Installed in control panel	
	Cooling	Natural air cooling	
	EMC	8kV	: Electrical Discharge
		10V/m	: Radiated Interference
		2K/1K/0.25KV	: Electrical Fast Transient
Grounding	Grounding resistance 100Ω or less		

Notes *1 Insulated Circuits

- between Power supply circuit and I/O circuit
- between Accessible metal parts and Power supply circuit
- between Accessible metal parts and I/O circuit
- between SELV circuit and Power supply
- between SELV circuit and I/O circuit

Accessible metal parts: Racks, Protective ground terminal, etc.

SELV (Safety Extra Low Voltage) circuit: Internal logic circuit

The accessible metal parts of the peripherals that are connected to the programmable controller with the standard cable, are connected to the Protective ground terminal, or double insulated.

Power Supply Specification

Item		Specification				
		PS691	PS693	PS694	PS632	PS652
Basic Function	Nominal Voltage	100-120Vac 200-240Vac	100-240Vac		24Vdc	100-110Vdc
	Power consumption	160VA (60W)	120VA (50W)	150VA (60W)	50W	
	Voltage Fluctuation Range	85-132Vac 170-264Vac	85-264Vac		20.4 - 28.8Vdc	85V - 132Vdc
	Power Supply Frequency	50/60Hz(47 to 63Hz)			DC	
	Retentive Power Interruptions	10ms or less (at maximum load for one power supply module)		20ms/1s ±30%/20S ±30% (switch setting)	1ms or less	
	Inrush current	12A (at 240Vac) (Voltage drop interval : more than 5sec.)	30A (at 220Vac) (Voltage drop interval : more than 5sec.)	25A (at 240Vac) (Voltage drop interval : more than 5sec.)	6.5A/10ms	25A
	Grounding current	1.5mA or less (IEC-950)				
	Insulation resistance	10MΩ or greater (between power terminals and ground terminals)				
	Withstand voltage	2500Vac - 1 minute				
	Grounding	Grounding resistance 100Ω or less				
	Output Rating	5Vdc-8A, 3.3Vdc-1.0A Total 43W or less	5Vdc-7A, 3.3Vdc-1.0A 24Vdc-0.8A Total 35W or less	5Vdc-6A, 3.3Vdc-1.0A Total 35W or less	5Vdc-7A, 3.3Vdc-1.0A Total 35W or less	
	Circuit Protection	Over voltage, over current				
Built-in Function	Status display	POWER (5Vdc output, Green)				
	RUN contact	Relay output (a-contact) (240Vac/24Vdc-Max. 0.2A)				
External Feature	Weight	650g or less	600g or less			
	Terminal Block	10pins -M3.5 screws (Remove)	9pins -M3.5 screws (Fixed)	10pins -M3.5 screws (Remove)	9pins -M3.5 screws (Fixed)	

2

Functional Specifications

Table2-1-1 Functional Specifications

Type		PU662T	PU672T	
Control method		Stored program, cyclic scan system		
Scan system		Floating scan or constant scan (10-200ms, 10ms units)		
I/O update		Batch I/O refresh (direct I/O instruction available)		
Program memory		Main memory: RAM (battery backed) Auxiliary memory: EEPROM (built-in)		
Program capacity		32 k steps	64 k steps	
Programming language		Ladder diagram with function block, SFC (sequential function chart)		
Instructions	Ladder	Basic instructions: 24 types, Function instructions: 206 types		
	SFC	Step, transition, sequence selection, simultaneous sequences, jump, etc.		
Execution speed		0.09 μ s/contact, 0.18 μ s/coil, 0.54 μ s/transfer, 0.90 μ s/addition		
Multitasking		1 Main program 4 Sub-program 1 Timer interrupt (1-1000ms, 1ms units) 8 I/O interrupt (task switch 500 μ s or less) 256 Subroutine		
I/O capacity		Local I/O space: 2048 points/128 words (X/XW and Y/YW: batch I/O) (I/IW and O/OW: direct I/O)		
User data	Auxiliary relay	16000 points/1000 words (R/RW)		
	Special relay	4096 points/256 words (S/SW)		
	Timer	1000 points (T./T) (proportion of 0.01s and 0.1s timer is user definable)		
	Counter	512 points (C./C)		
	Data register	8192 words (D)		
	Link register	16000 points/2048 words (Z/W) (for TOSLINE-S20)		
	Link relay	4096 points/256 words (L/LW) (for TOSLINE-F10)		
	File register	32768 words (F)	32768 words (F), 512 k words (expanded F)	
	Index register	3 words (I, J, K)		
	Retentive memory	F register and user defined ranges of RW, T, C, D		
RAS	Self-diagnosis	Power interruption, power failure, CPU/RAM/ROM check, I/O response, I/O bus check, I/O registration, I/O parity, battery level, watch dog timer, program check, others		
	Monitoring	Event history record, scan time measurement, others		
	Debugging	On-line trace monitor, force, sampling trace, status latch, single step/N scan execution, break point, others		
RAM data back-up		Lithium battery (type: GBT611*AS) Recommended replacement: every 2 years		

2.2 External dimensions

Main base for Station Modules(BU648E, BU643D),

Main base for CPU without station bus/expansion base(BU668, BU666, BU664)

BU648E, BU668

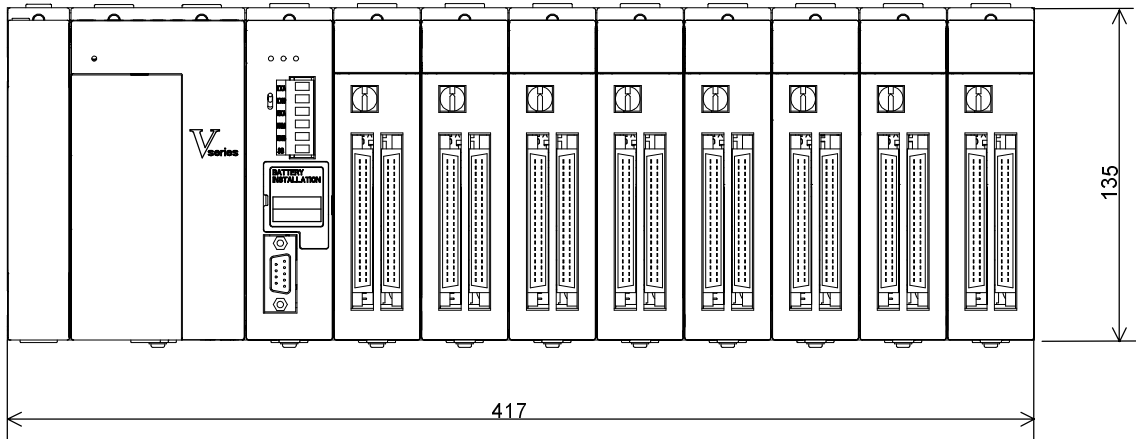

2

BU666

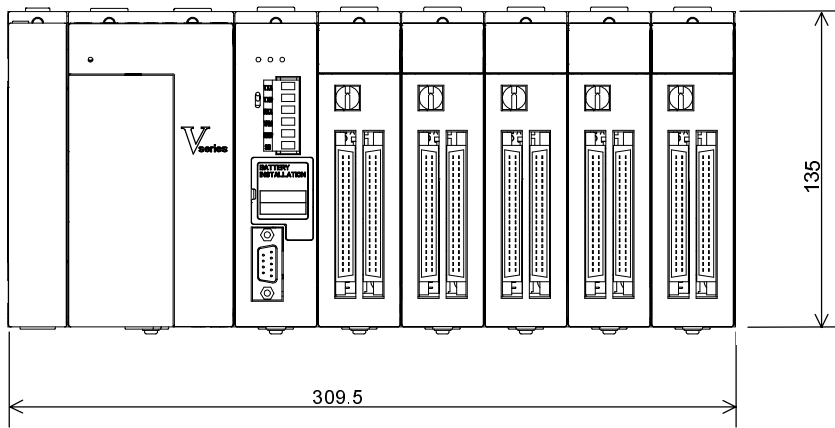

BU643D, BU664

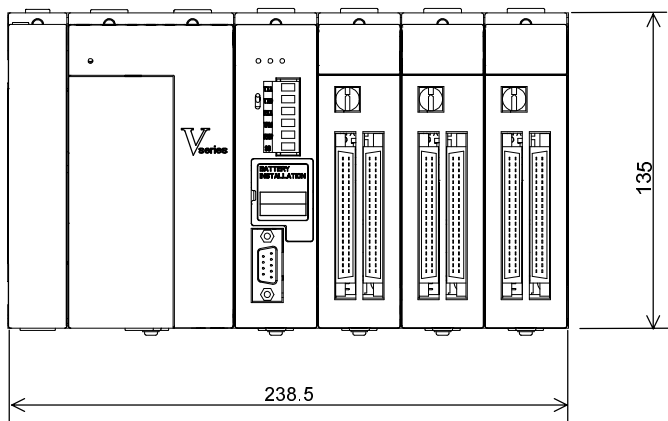

When 8/16-point I/O module installed

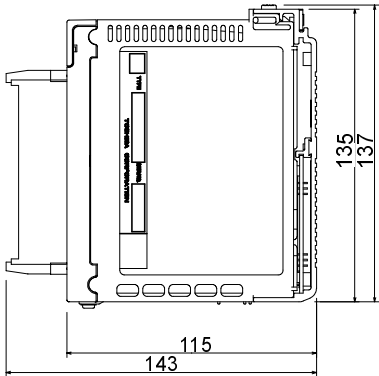

When 32/64-point I/O, PI632/672, MC612 installed

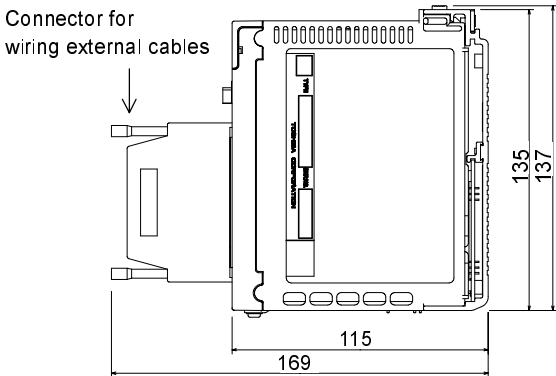

2.3 I/O Module Specification

■ DI633

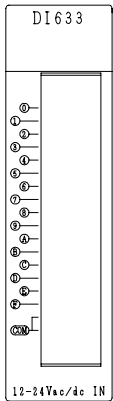

Item		DI633
No. of input point		16 points
Input Voltage Range		12-24V ^{+10%} / _{-15%} dc/ac(50/60Hz)
Input current (typ.)		Approx. 8mA (at 24Vdc)
Minimum ON Voltage		9.6V or more
Maximum OFF Voltage		3.6V or less (leak current 0.7mA or less)
Delay time	ON Delay (OFF to ON)	10ms or less (dc)/ 20ms or less (ac)
	OFF Delay (ON to OFF)	10ms or less (dc)/ 20ms or less (ac)
External connections		18-point terminal block
Common configuration	No. of commons	1
	No. of input points per common	16 points
	Common polarity	No polarity
Derating condition		Non
Current consumption		15mA (5Vdc) or less
Withstand voltage		1500Vac / 1 minute
Weight		Approx. 250g

Circuit Configuration

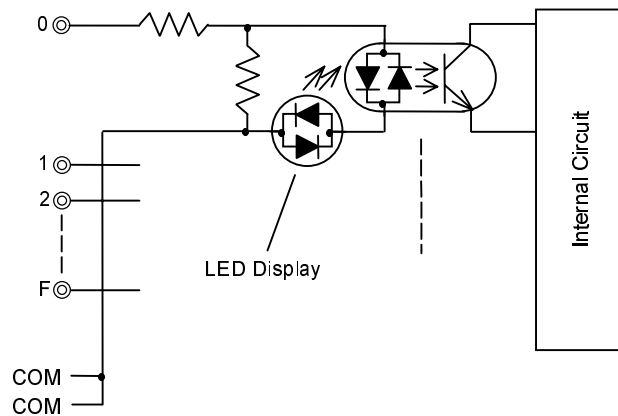

Terminal Connections

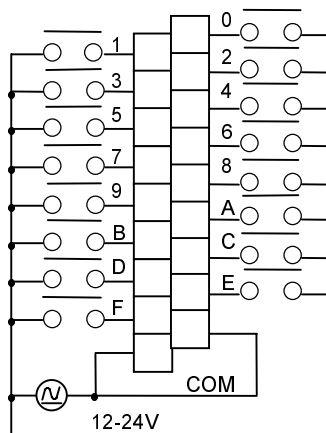

2

■ DI632D

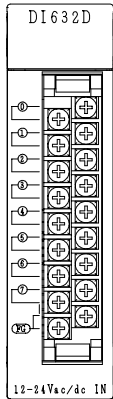

Item		DI632D
No. of input point		8 points
Input Voltage Range		12-24V $\begin{matrix} +10\% \\ -15\% \end{matrix}$ dc/ac(50/60Hz)
Input current (typ.)		Approx. 8mA (at 24Vdc)
Minimum ON Voltage		9.6V or more
Maximum OFF Voltage		4.3V or less
Delay time	ON Delay (OFF to ON)	10ms or less (dc)/ 20ms or less (ac)
	OFF Delay (ON to OFF)	10ms or less (dc)/ 20ms or less (ac)
External connections		18-point terminal block
Common configuration	No. of commons	1
	No. of input points per common	16 points
	Common polarity	No polarity
Derating condition		Non
Current consumption		100mA (5Vdc) or less
Withstand voltage		1500Vac / 1minute
Weight		Approx. 200g

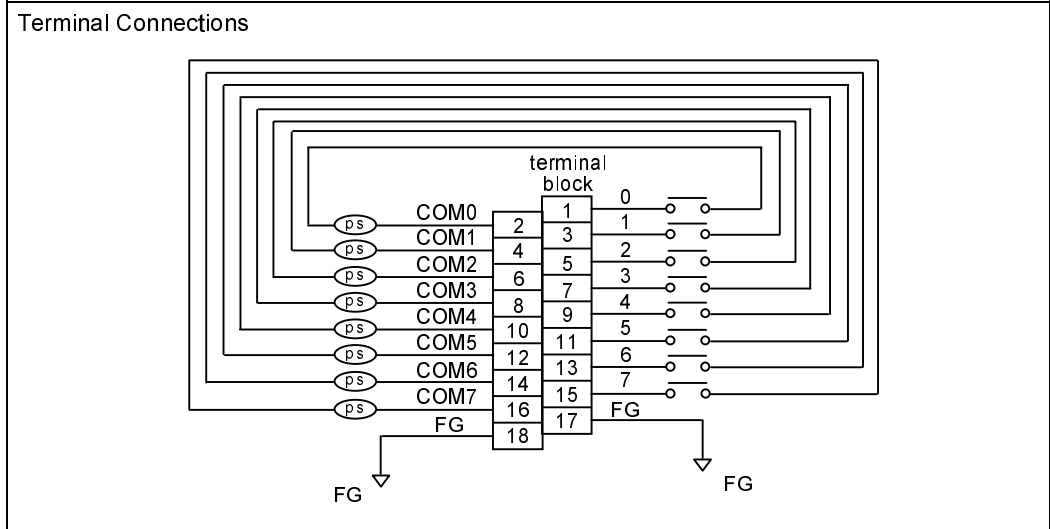
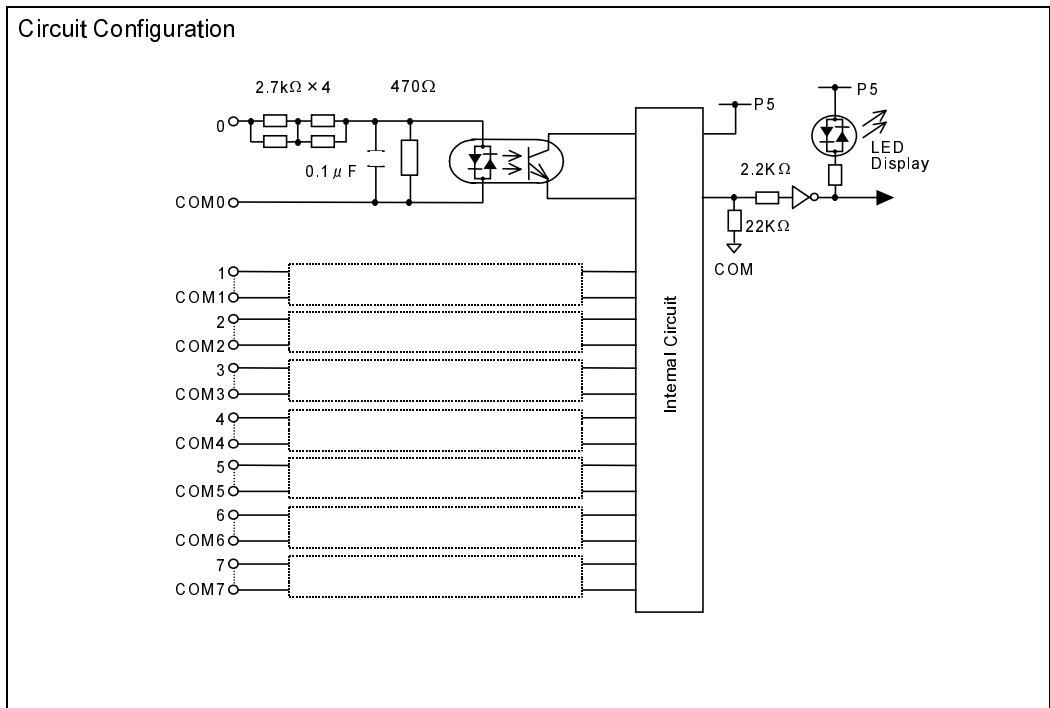

2

■ DI653

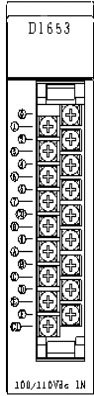

Item		DI653
No. of input point		16 points
Input Voltage Range		100-110Vac $\begin{matrix} +10\% \\ -15\% \end{matrix}$
Input current (typ.)		Approx. 2.3mA (at 100Vdc)
Minimum ON Voltage		84V or more
Maximum OFF Voltage		22V or less
Delay time	ON Delay (OFF to ON)	10ms or less
	OFF Delay (ON to OFF)	10ms or less
External connections		18-point terminal block
Common configuration	No. of commons	1
	No. of input points per common	8 points
	Common polarity	No polarity
Derating condition		See below
Current consumption		100mA (5Vdc) or less
Withstand voltage		1500Vac / 1 minute
Weight		Approx. 250g

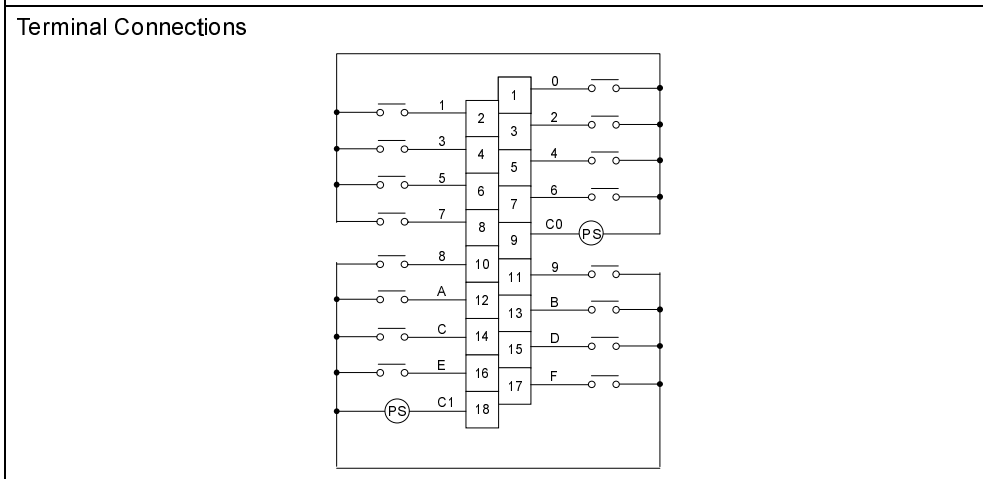
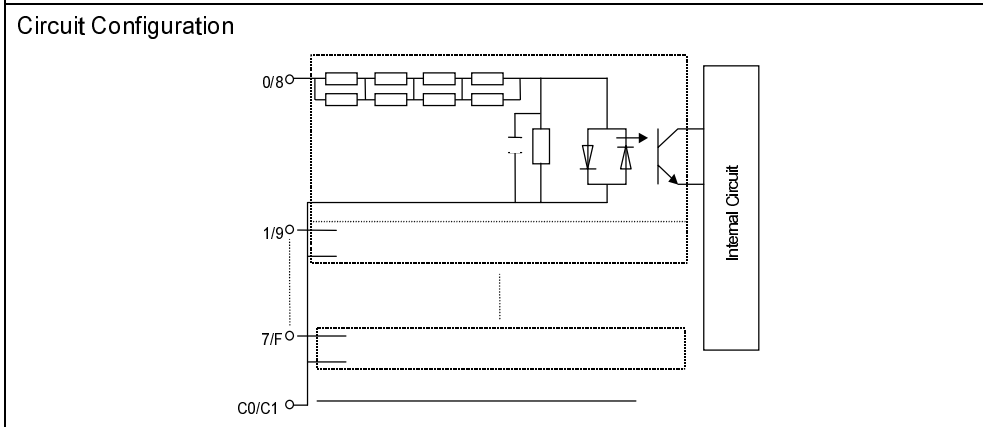
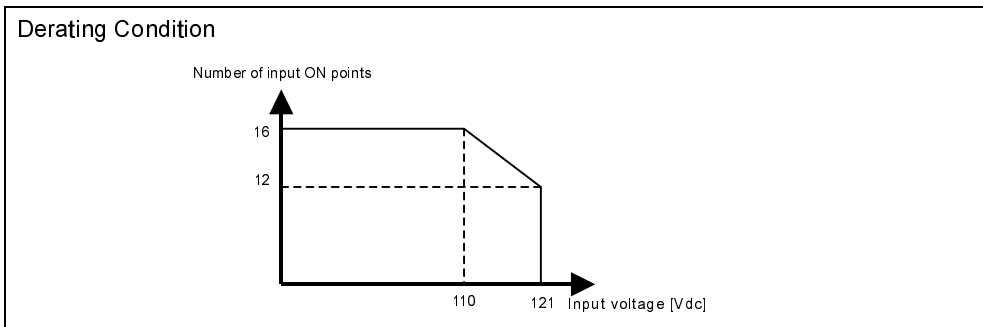

2

■ DI634&635

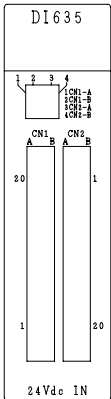
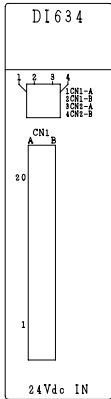

Item		DI634	DI635
No. of input point		32 points	64 points
Input Voltage Range		24Vdc ^{+10%} _{-15%}	
Input current (typ.)		Approx. 4mA (at 24Vdc)	
Minimum ON Voltage		16V or more	
Maximum OFF Voltage		5V or less	
Delay time	ON Delay (OFF to ON)	10ms or less	
	OFF Delay (ON to OFF)	15ms or less	
External connections		1×40pin connector	2×40pin connectors
Common configuration	No. of commons	4 (isolated between channels)	8 (isolated between channels)
	No. of input points per common	8 points	
	Common polarity	No polarity	
Derating condition		Derate simultaneous input ON points under the condition that operating temperature is over than 40°C at the DI635	
Current consumption		70mA (5Vdc) or less	100mA (5Vdc) or less
Withstand voltage		1500Vac /1minute	
Weight		Approx. 200g	Approx. 250g

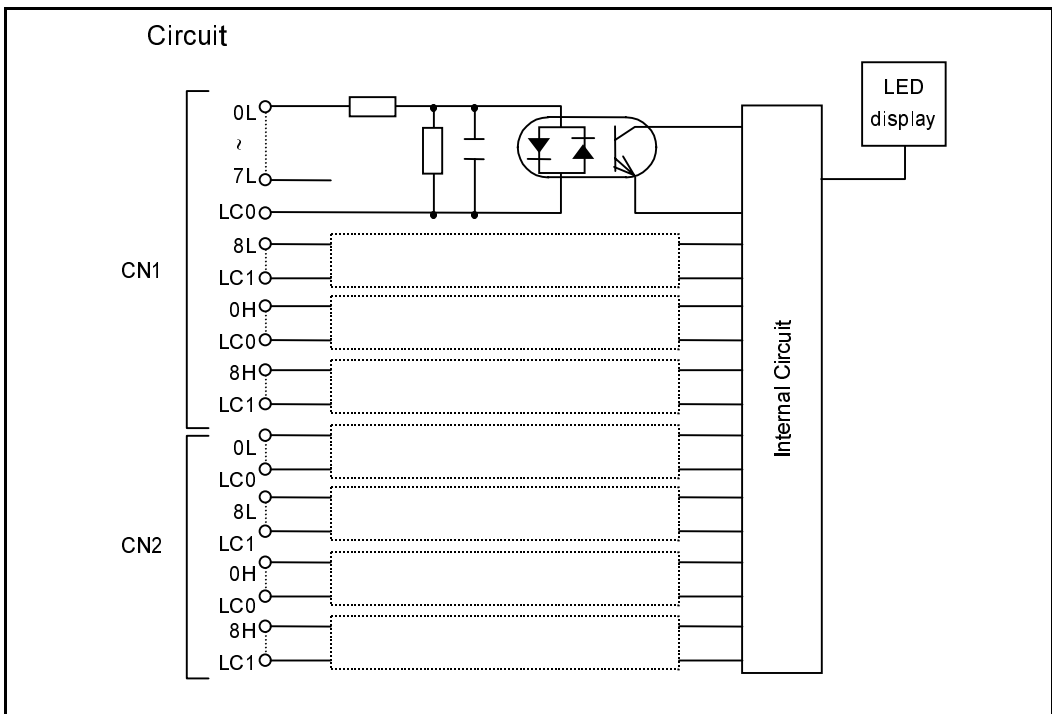

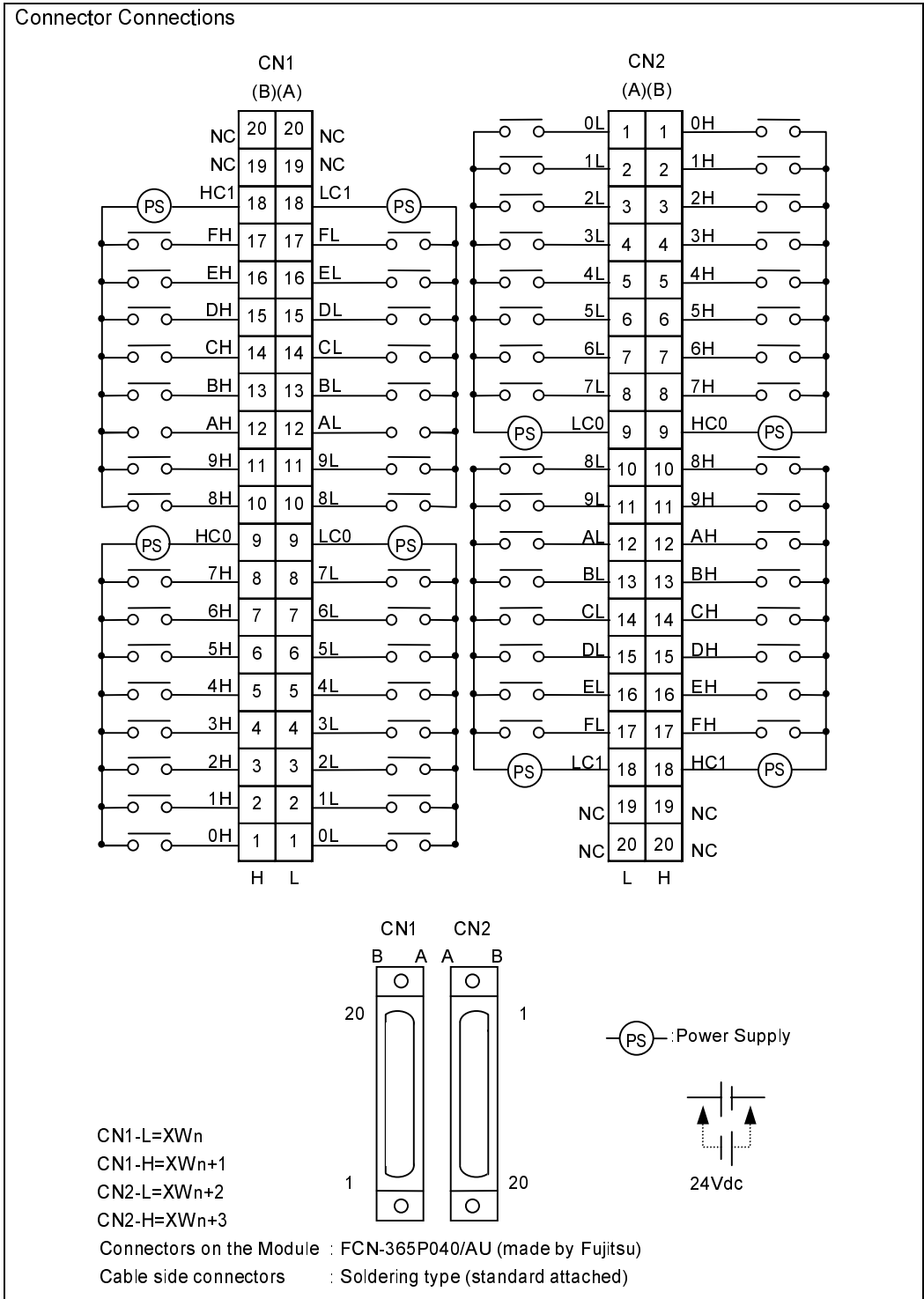

(Derating Condition DI635)

Number of input ON points (per 1connector)

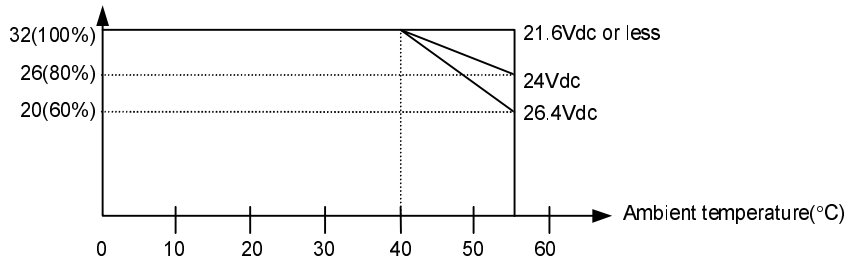

■ IN653/663

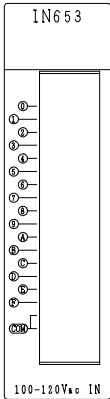

Item		IN653	IN663
No. of input point		16 points	16 points
Input Voltage Range (Sine wave)		100-120Vac ^{+10%} / _{-15%} (50/60Hz)	200-240Vac ^{+10%} / _{-15%} (50/60Hz)
Input current (typ.)		Approx. 7mA (at 100Vac-50Hz)	Approx. 6mA (at 200Vac-50Hz)
Minimum ON Voltage		80Vac or more	160Vac or more
Maximum OFF Voltage		30Vac or less (leak current 2mA or less)	60Vac or less (leak current 2mA or less)
Delay time	ON Delay (Sine wave)	20ms or less	20ms or less
	OFF Delay (Sine wave)	15ms or less	15ms or less
External connections		18-point terminal block	
Common configuration	No. of commons	1	1
	No. of input points per common	16 points	16 points
	Common polarity	No polarity	
Current consumption		15mA (5Vdc) or less	
Withstand voltage		1500Vac /1 minute	
Weight		Approx. 300g	Approx. 300g

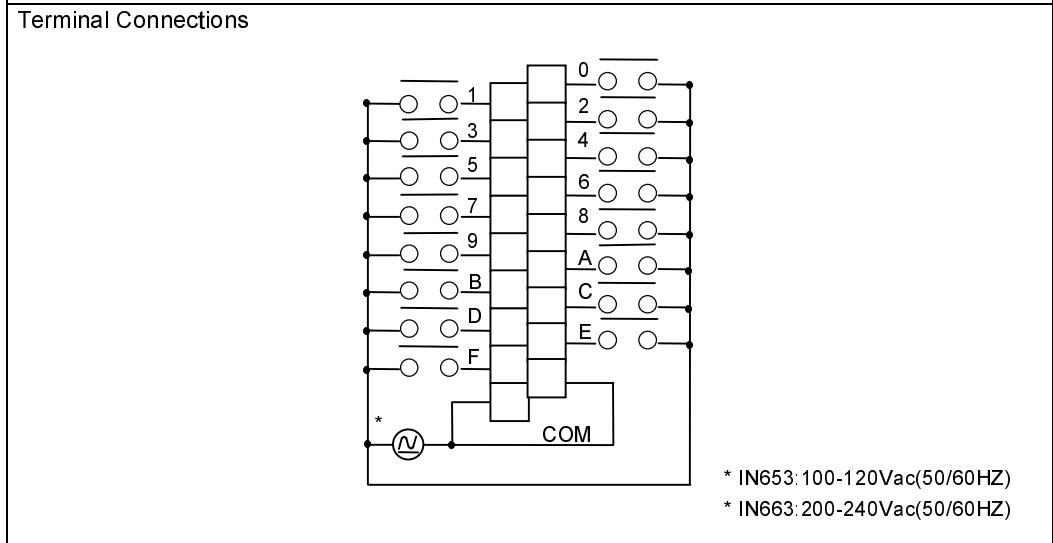
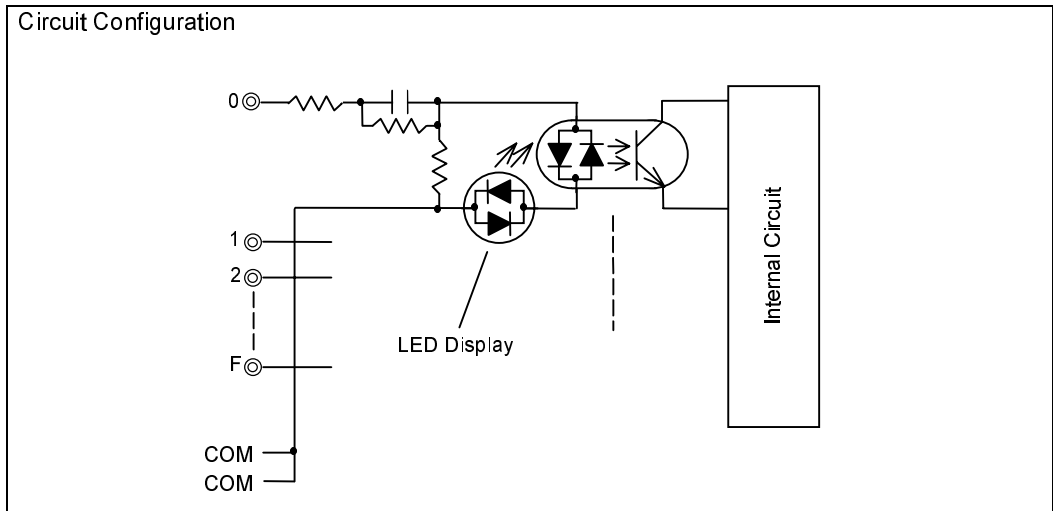

NOTE

Input voltage use the power supply of distortion factor 5% or less.

■ RO662S

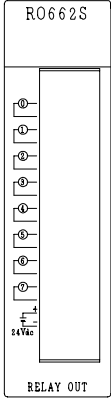

Item		RO662S
No. of output point		8 points (each point isolated)
Load Voltage		110Vdc, +10%(Max.) /240Vac, +10%(Max.)
Maximum Load		2A/point (resistive load) and 1A/point (inductive load) at 240Vac/24Vdc 0.5A/point (resistive load) and 0.1A/point (inductive load) at 110Vdc
Minimum Load		50mW (5Vdc or more)
Delay time	ON Delay	10ms or less
	OFF Delay	15ms or less
Leakage current when OFF		0mA or less
External connections		18-point terminal block
Common configuration	No. of commons	1
	No. of output points per common	1 point
	Common polarity	No polarity
Current consumption		40mA (5Vdc) or less
Withstand voltage		1500Vac /1minute
External Relay Coil Power Required		24Vdc±10%-100mA/all points ON (10mA/ point)
ON/OFF life of relays		Electrical : See the figures of life curves of the output relay, Mechanical : 20million times
Weight		Approx. 250g

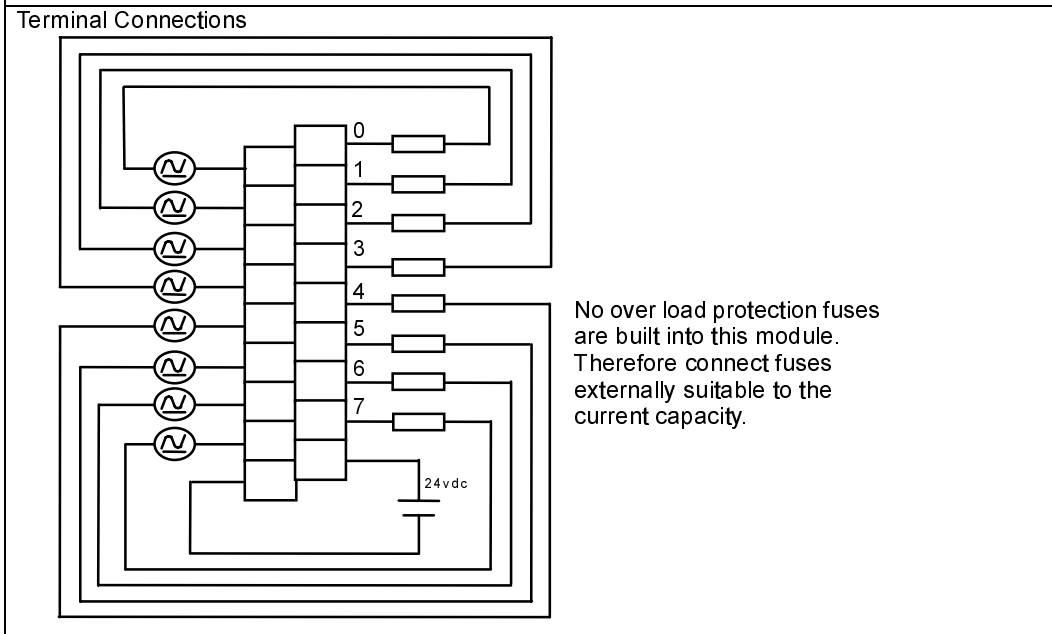
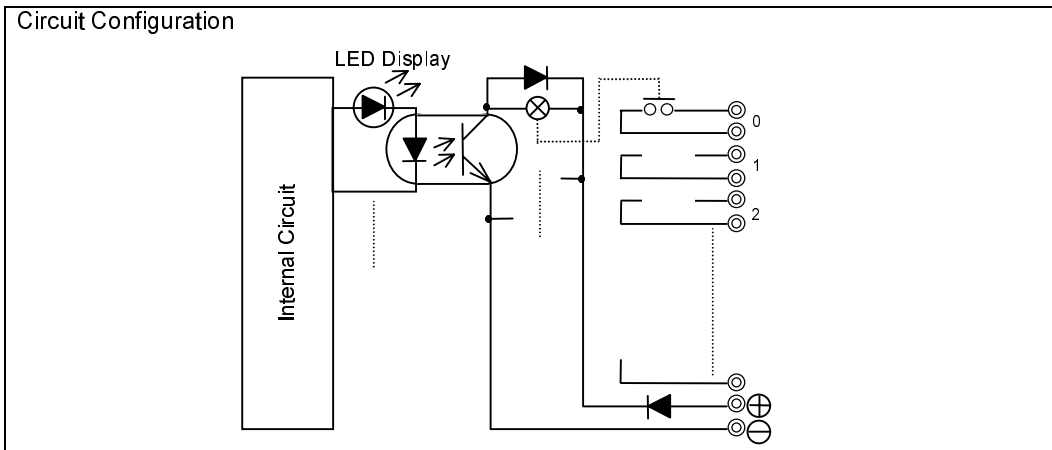

2

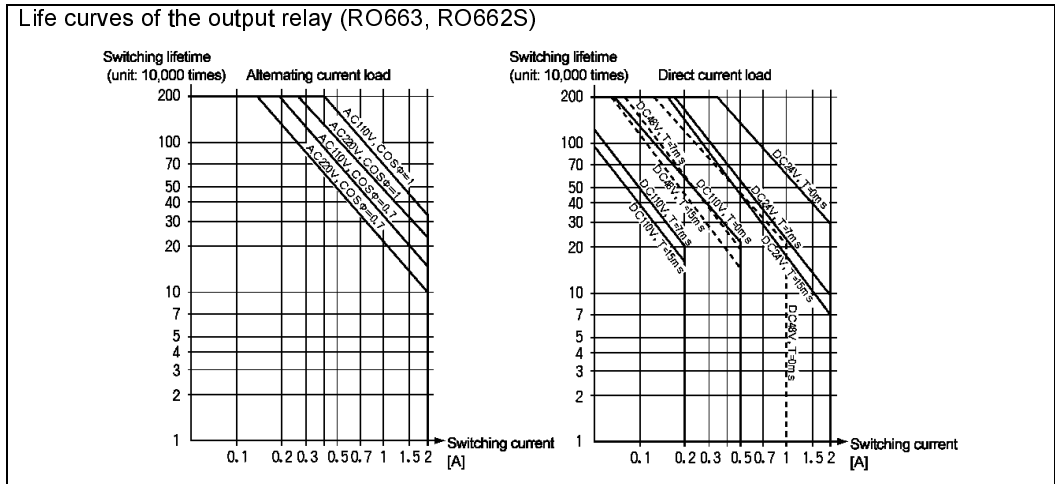

NOTE

1. The data are based on 1800 switching times / hour. For more frequently operation, the life of the output relay will become shorter.
2. In the case of RO662S, the data in the above figure is not applicable when the color of the 'RELAY OUT' characters on the front panel is white.

2

■ RO663

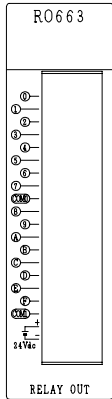

Item		RO663
No. of output point		16 points
Load Voltage		24Vdc, +20%(Max.) /240Vac, +10%(Max.)
Maximum Load		2A/point (resistive load), 1A/point (inductive load), 8A/8 points common
Minimum Load		50mW (5Vdc or more)
Delay time	ON Delay	10ms or less
	OFF Delay	15ms or less
Leakage current when OFF		0mA or less
External connections		20-point terminal block
Common configuration	No. of commons	2
	No. of output points per common	8 point
	Common polarity	No polarity
Current consumption		80mA (5Vdc) or less
Withstand voltage		1500Vac /1minute
External Relay Coil Power Required		24Vdc±10%-90mA/all points ON (5mA/ point)
ON/OFF life of relays		Electrical : See the figures of life curves of the output relay, Mechanical : 20million times
Weight		Approx. 250g

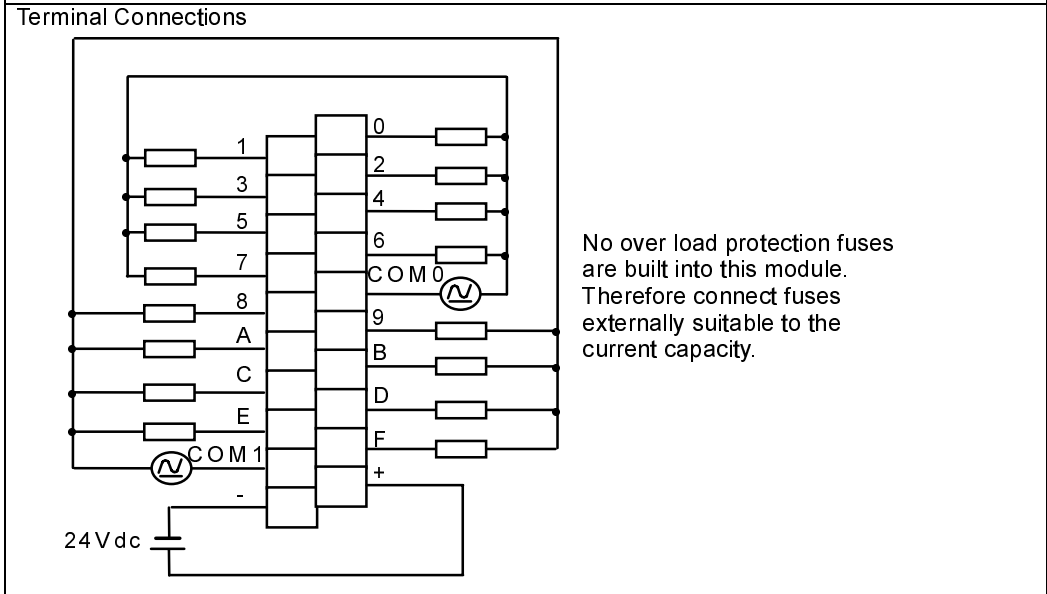
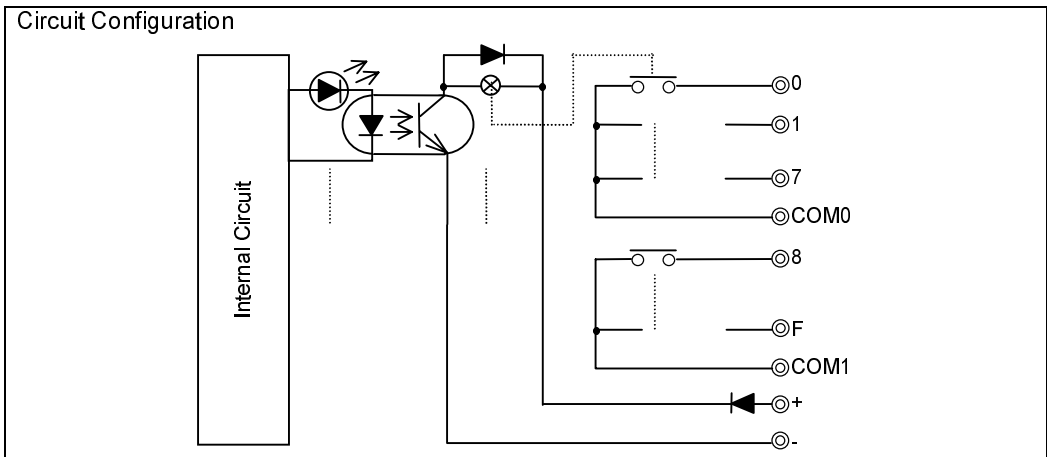

2

■ DO633

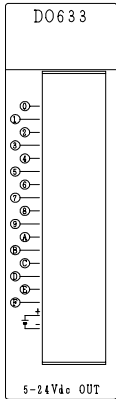

Item		DO633
No. of output point		16 points
Load Voltage		5-24Vdc $\begin{matrix} +10\% \\ -5\% \end{matrix}$
Maximum Load		1A/point (external power supply : 7Vdc or more) 0.3A/point (external power supply : 7Vdc or less) 1.2A/4points (4-element transistor array)
Output ON resistance		1.5 Ω or less
Delay time	ON Delay	1ms or less
	OFF Delay	1ms or less
Leakage current when OFF		0.1mA or less
External connections		18-point terminal block
Common configuration	No. of commons	1
	No. of output points per common	16 points
	Common polarity	Minus common (SINK type output)
Current consumption		60mA (5Vdc) or less
Withstand voltage		1500Vac /1minute
Built-in fuse		5A
Weight		Approx. 300g

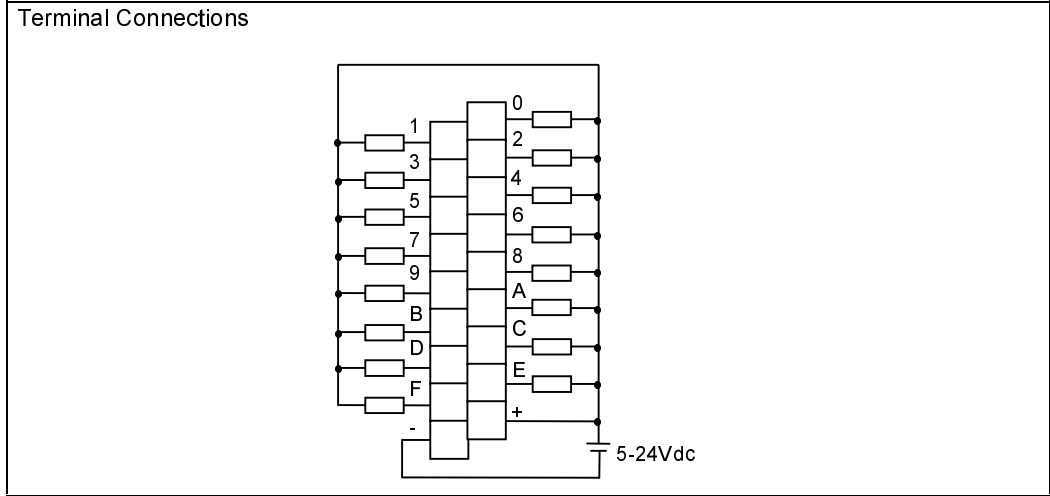
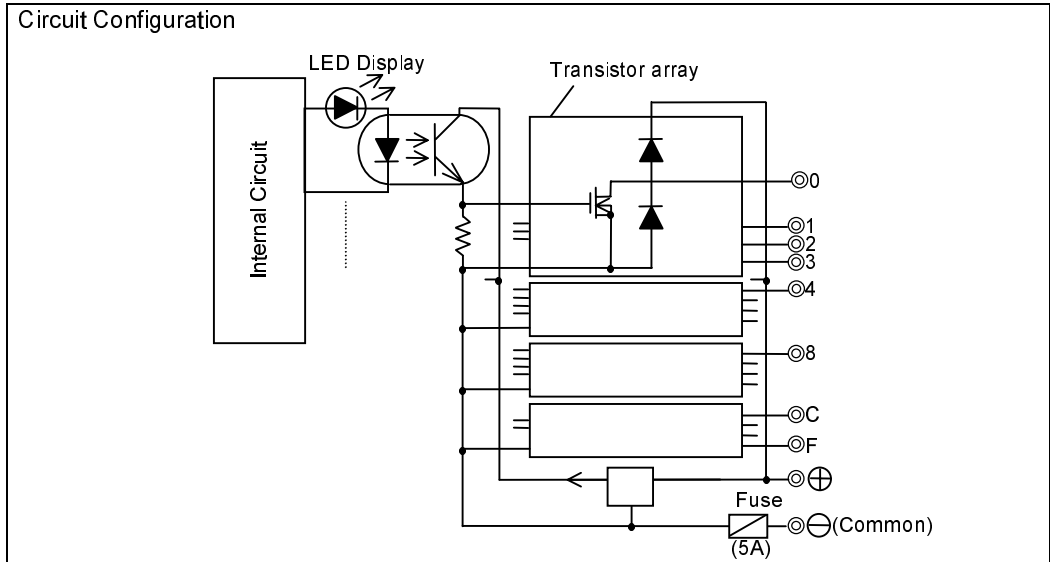

2

■ DO634&DO635*1

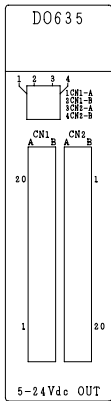
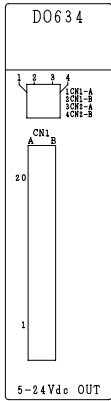

Item		DO634	DO635
No. of output point		32points	64points
Load Voltage		5-24Vdc +10% -15%	
Maximum Load		0.1A/point (DC9.6 - 26.4Vdc) 0.05A/point (DC4.5 - 9.5Vdc) 0.8A/common	
Saturation voltage when ON		0.4V or less	
Leakage current when OFF		0.1mA or les (at 24Vdc)	
Delay time	ON Delay	1ms or less	
	OFF Delay	1ms or less	
External connections		1×40pin connectors	2×40pin connectors
Common configuration	No. of commons	4	8
	No. of output points per common	8 points	
	Common polarity	Minus common (SINK type output)	
Current consumption		150mA (5Vdc) or less	250mA (5Vdc) or less
Withstand voltage		1500Vac /1minute	
Built-in fuse		None	
Weight		Approx. 200g	Approx. 300g

(*1) When executing direct output (out of batch output), four registers (one module) should be specified to direct output. Batch/direct out put can's be mixed in one module.

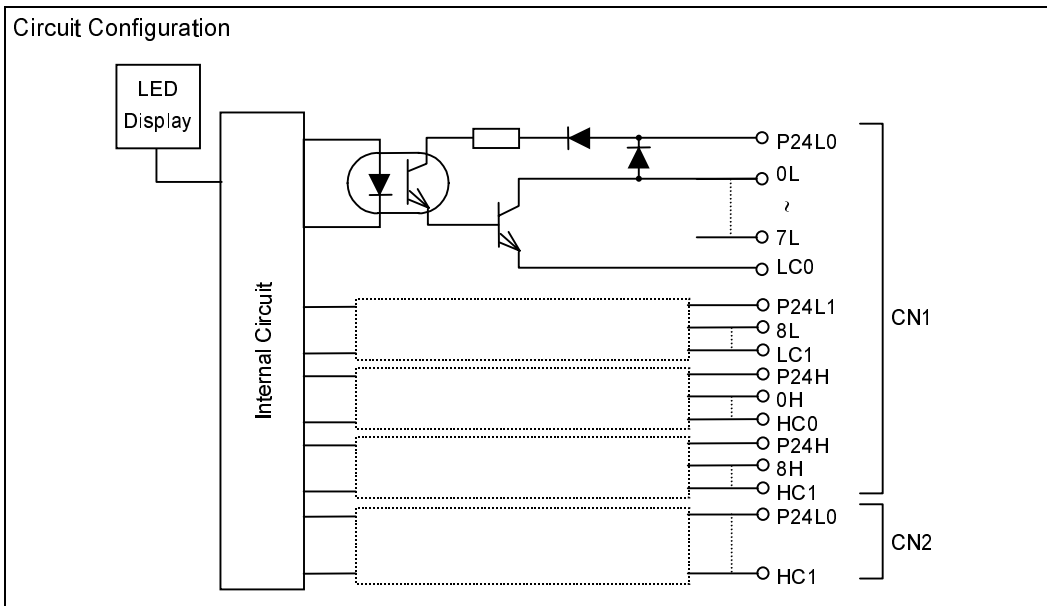

2

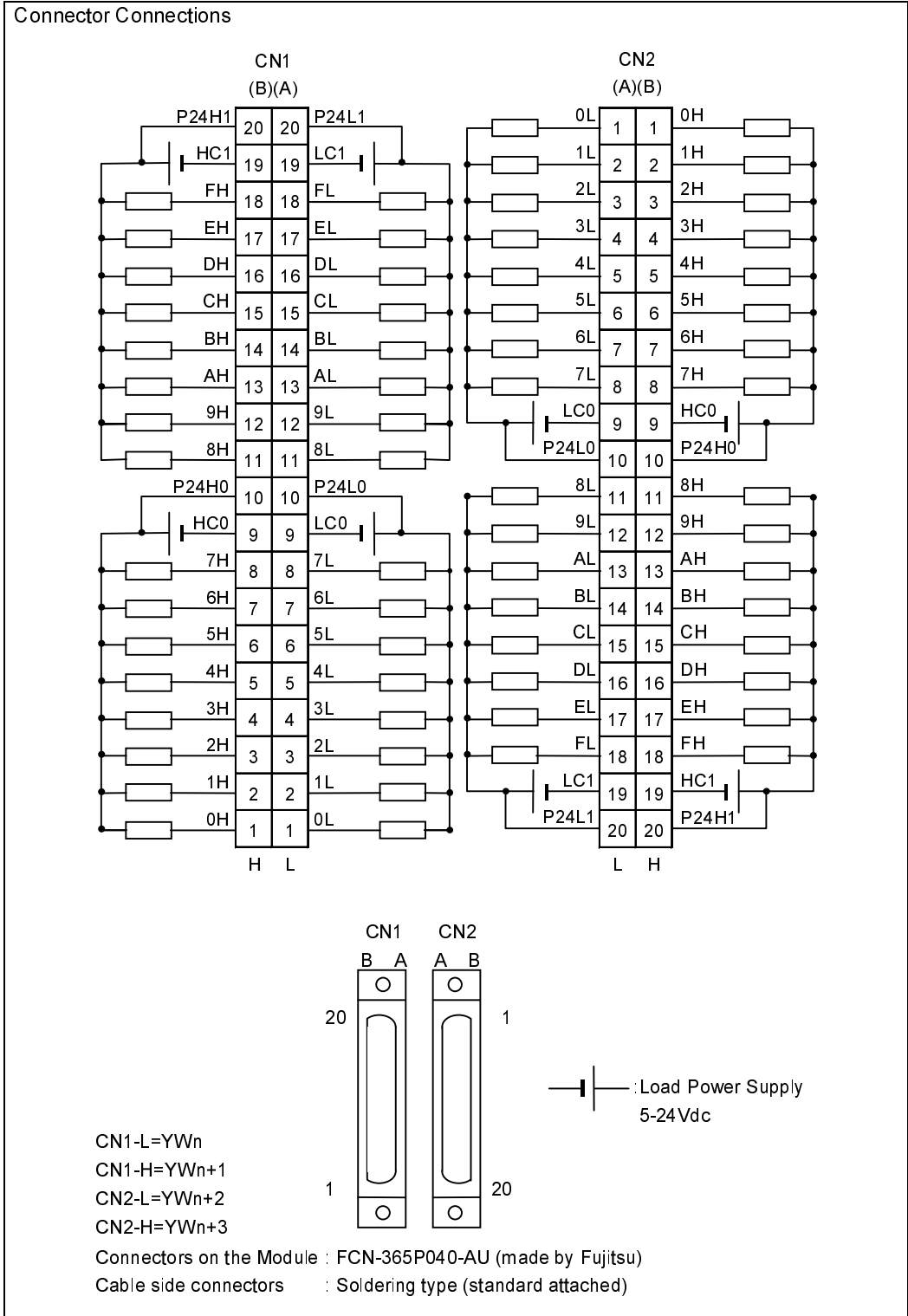

■ DO633P

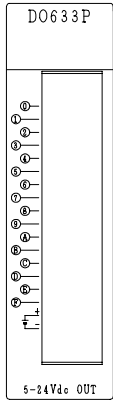

Item		DO633P
No. of output point		16 points
Load Voltage		12-24Vdc $\begin{matrix} +10\% \\ -15\% \end{matrix}$
Maximum Load		1A/point 1.2A/4points (4-element transistor array)
Output ON resistance		1.5W or less
Delay time	ON Delay	1ms or less
	OFF Delay	1ms or less
Leakage current when OFF		0.1mA or less
External connections		18-point terminal block
Common configuration	No. of commons	1
	No. of output points per common	16 points
	Common polarity	Plus common (SOURCE type output)
Current consumption		60mA (5Vdc) or less
Withstand voltage		1500Vac /1minute
Built-in fuse		5A
Weight		Approx. 200g

2

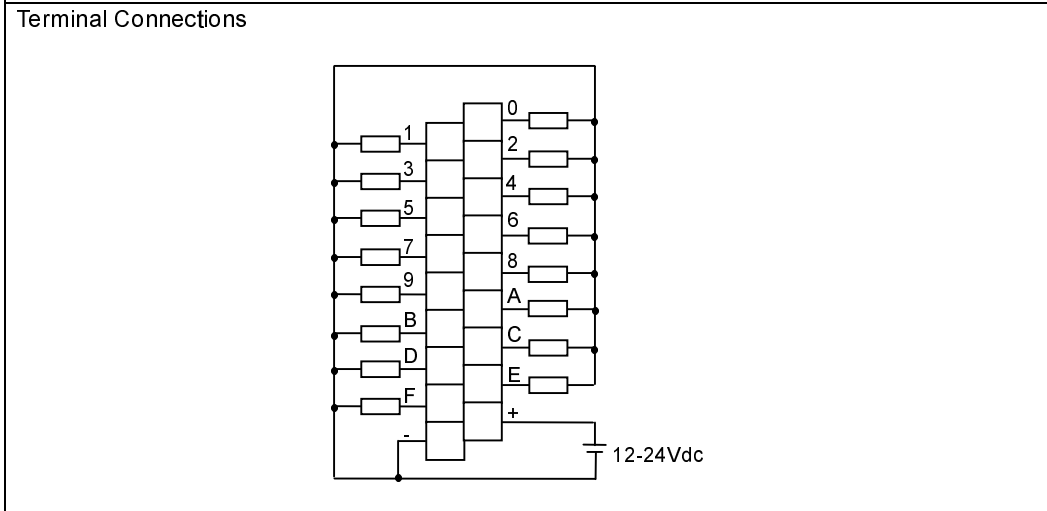
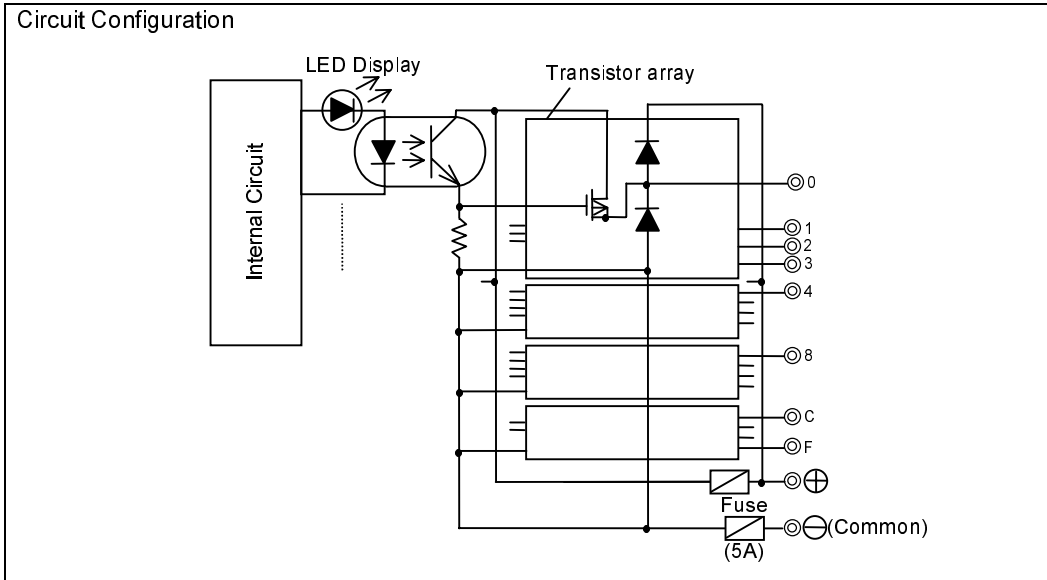

■ AC663

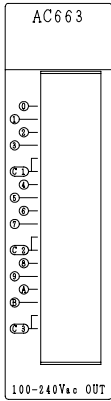

Item		AC663
No. of output point		12 points
Load Voltage		100-240Vac $\begin{matrix} +10\% \\ -15\% \end{matrix}$ (50/60Hz sine wave)
Maximum Load		0.5A/point 0.6A/4points (2-element SSR)
Saturation voltage when ON		1.5V or less (at 0.3A load)
Leakage current when OFF		1.2mA or less (at 100Vac), 3mA or less (at 240Vac)
External connections		18-point terminal block
Delay time	ON Delay	1ms or less
	OFF Delay	1/2 cycle of load power supply + 1ms or less
Current consumption		300mA (5Vdc) or less, (20mA/point)
Withstand voltage		1500Vac /1minute
Built-in fuse		2A
Weight		Approx. 300g

Circuit Configuration

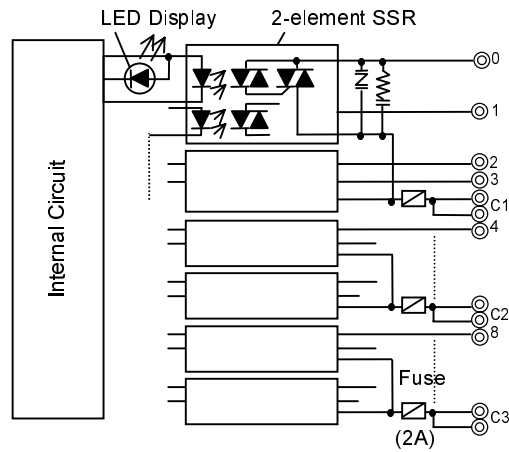

Terminal Connections

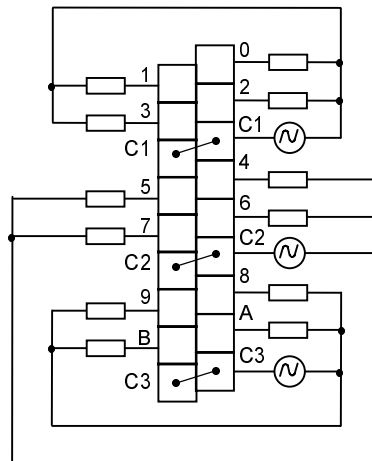

2

■ CD633

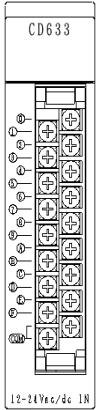

Item		CD633
Category		DC input with interrupt generation
Input type		Current sinking/sourcing
Number of input points		16 points, 1-word input[not update in the batch I/O processing]
Rated input voltage		12 to 24 Vdc
Range input voltage		10.2 to 26.4 Vdc
Rated input current		7mA (at 24 Vdc)
Input impedance		3.3KΩ
Operating voltage Delay	Min ON voltage	9.6 V
	Max OFF voltage	3.6 V
	OFF to ON	1 ms or less
	ON to OFF	1 ms or less
Minimum input pulse width		1ms
Internal sampling cycle		32μs
Configuration of common	No. of common	1
	No. of input points per common	16 points/common
	Polarity of common	No polarity
External connection		18 points terminal block (removable)
Derating condition		None
Internal current consumption		200 mA or less (5 Vdc)
Insulation resistance		10Ω or more (at 500 Vdc)
Withstand voltage		1500 Vac, 1 minutes(between internal and external circuits)
Weight		Approximately 250g

2

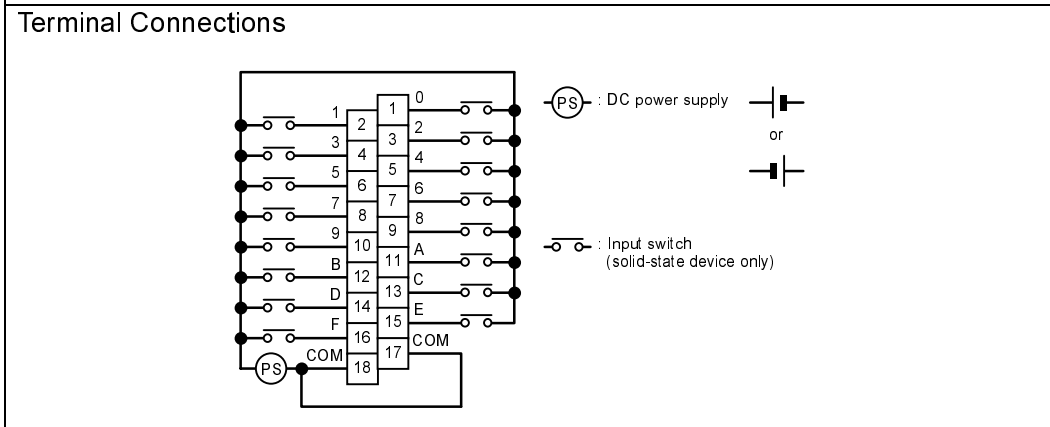
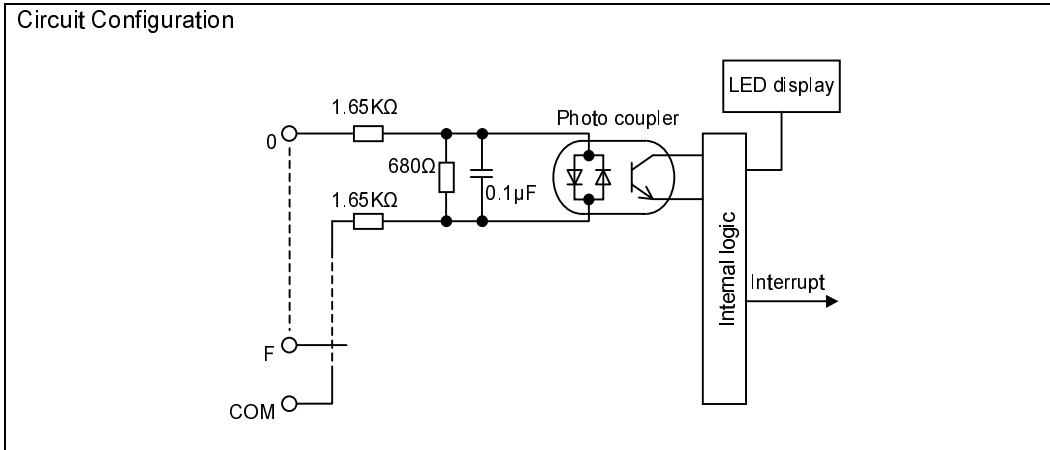

Data format

(1) Basic registers

Change detection status and Input data

S2T	S2	Description
XWn	%IWn	Rising edge detection status
XWn+1	%IWn+1	Falling edge detection status
XWn+2	%IWn+2	Input data
XWn+3	%IWn+3	No use (reserved)

[Rising edge detection status bit assignment]

Bit	F	E	D	C	B	A	9	8	7	6	5	4	3	2	1	0
	US	US	US	US	US	US	US	US	US	US	US	US	US	US	US	US

US: When corresponding bit of input data changes from OFF to ON, it sets to '1'.

[Falling edge detection status bit assignment]

Bit	F	E	D	C	B	A	9	8	7	6	5	4	3	2	1	0
	LS	LS	LS	LS	LS	LS	LS	LS	LS	LS	LS	LS	LS	LS	LS	LS

LS: When corresponding bit of input data changes from ON to OFF, it sets to '1'.

[Input data bit assignment]

Bit	F	E	D	C	B	A	9	8	7	6	5	4	3	2	1	0
	F	E	D	C	B	A	9	8	7	6	5	4	3	2	1	0

This register reflects the current input signal status.

When the interrupt enable flag is set to ON (DE='1') and the rising edge detection is selected (UE='1'), the CD633 sets corresponding bit of the change detection status register (US) and generates interrupt to the controller at the time of input signal change from OFF to ON.

As same manner, when the falling edge detection is selected (LE='1'), the CD633 generates interrupt at the time of input signal change from ON to OFF.

If both UE and LE are set '1', the interrupt is generated at the time of both change from OFF to ON and from ON to OF

The change detection status is cleared to '0', when the controller is read the change detection status and input data. Therefore make the application program to read the change detection status and input data (3 words) at the same time by the direct I/O instruction, in the I/O interrupt program.

(2) Mode selection registers
 These registers are accessed by the special module data write instruction (WRITE instruction in S2T, MWRITE instruction in S2)

Address	Description
0	Rising edge detection select register
1	Falling edge detection select register
2	Change detection enable register

[Rising edge detection select register bit assignment]

Bit	F	E	D	C	B	A	9	8	7	6	5	4	3	2	1	0
	UE	UE	UE	UE	UE	UE	UE	UE	UE	UE	UE	UE	UE	UE	UE	UE

UE: When '1', the interrupt is generated at the time of corresponding input is changed OFF to ON. (Initial value is all '1')

[Falling edge detection select register bit assignment]

Bit	F	E	D	C	B	A	9	8	7	6	5	4	3	2	1	0
	LE	LE	LE	LE	LE	LE	LE	LE	LE	LE	LE	LE	LE	LE	LE	LE

[Change detection enable register bit assignment]

Bit	F	E	D	C	B	A	9	8	7	6	5	4	3	2	1	0
	-	-	-	-	-	-	-	-	-	-	-	-	-	-	-	DE

DE: When '1', change detection is enabled.
 When '0', change detection is disabled and change detection status is cleared. (Initial value is '1')

[Caution]
 I/O interrupt is not generated when the bit DE is '0'.

After power on initializing, the change detection mode of all bits is set only rising edge detection is enabled.

In order to change the mode of change detection, write data in the mode register by the special module data write instruction (WRITE instruction in S2T, MWRITE instruction in S2) in the user program.

Refer to the instruction manual for details of the special module data write instruction.

■ AD624L&AD634L

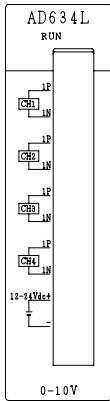
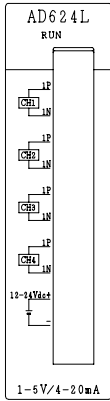

Item	AD624L	AD634L
No. of input channel	4 channels (N side common)	4 channels (N side common)
Input Range	1 - 5Vdc or 4 - 20mA*1	0 - +10Vdc
Input Impedance	500kΩ or more (1-5V) 250Ω (4-20mA)	500kΩ or more
Resolution	1 - 5V : 0 - 250 4 - 20mA : 0 - 250	0 - +10V : 0 - 250
Overall Accuracy	±0.5%FS/25°C ±1%FS /0 - 55°C	±0.5%FS/25°C ±1%FS /0 - 55°C
Conversion Cycle	Approx. 1ms/channel	Approx. 1ms/channel
Wire breakage detection	Only possible for 4 - 20mA	-
External Power Supply failure detection	available	available
Current consumption	50mA (5Vdc) or less	50mA (5Vdc) or less
Withstand voltage	1500Vac /1minute	1500Vac /1minute
External Power required	12-24Vdc±10%-70mA	12-24Vdc±10%-50mA
Weight	Approx. 200g	Approx. 200g

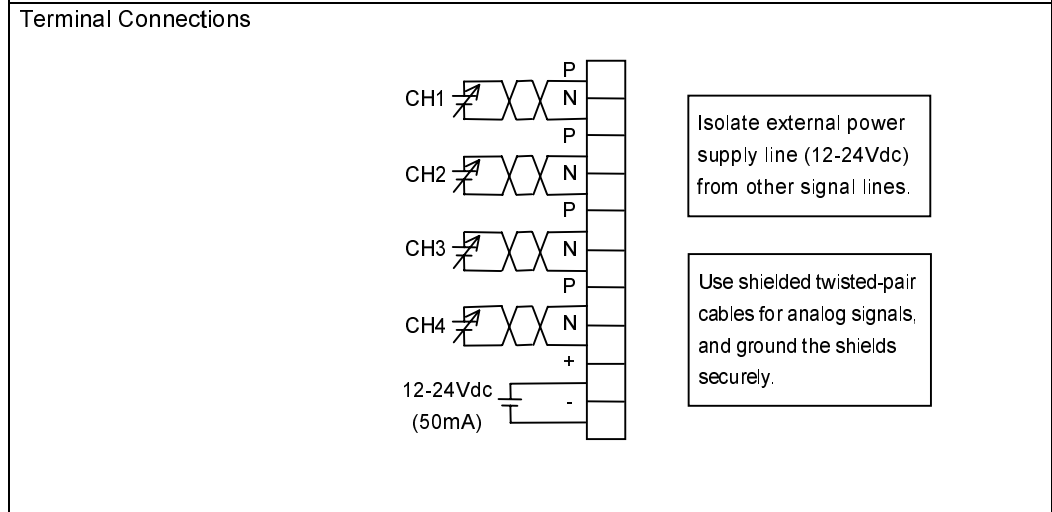
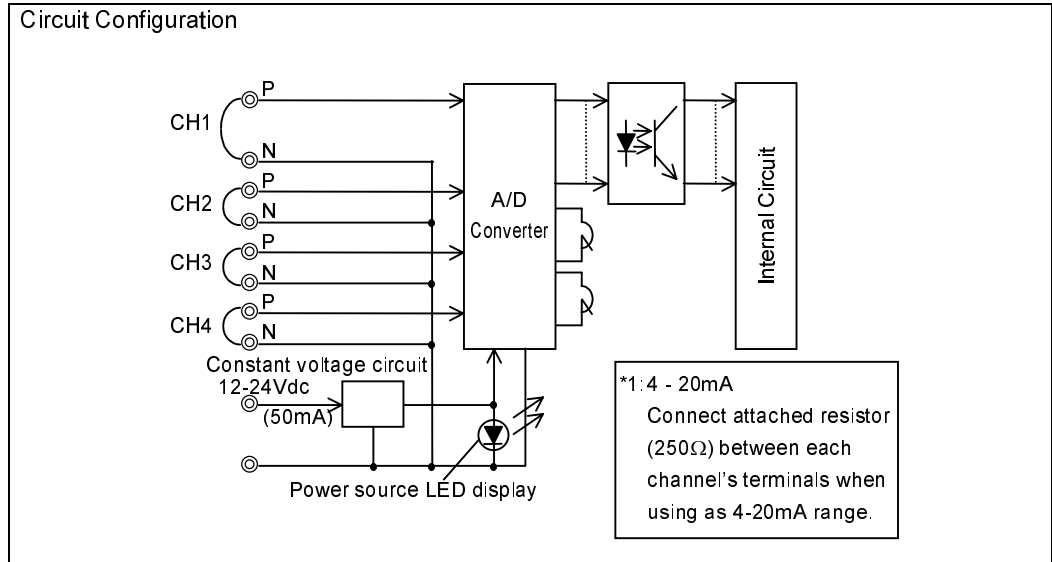

2

A/D Conversion

(a) 4-20mA range : $D=15.625 \times A - 62.5$

(b) 1-5V range : $D=62.5 \times A - 62.5$

(c) 0-10V range : $D=25 \times A$

[D: Digital value
A: Analog value]

Data Format

	F	E	D	C	B	A	9	8	7	6	5	4	3	2	1	0
XW	B	*	*	*	*	*	*	*	D	D	D	D	D	D	D	D

D: Data bit (8bits)
0-250 (H00 - HFA)
(Over-voltage/over-current input 255 counts)

B: External line abnormal detection bit
0= Normal

1=Abnormal {
When all data bits are 0 ** Current input line open
When all data bits are 1 ** External power is OFF

*: Always 0

4 words occupied (X4W)

XWn	CH1
XWn+1	CH2
XWn+2	CH3
XWn+3	CH4

NOTE

1. In the voltage input specification, the data bits do not become 0 when there is an open circuit between the input terminals. (They become indeterminate between 0 and 250.)
2. It is recommended that unused channels are shorted between the input terminals.

■ AD624&AD674

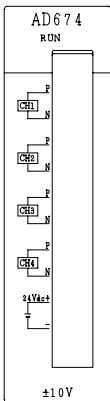
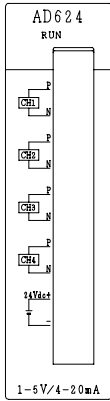

Item	AD624	AD674
No. of input channel	4 channels (N side common)	4 channels (N side common)
Input Range	1 - 5Vdc or 4 - 20mA*1	-10Vdc - +10Vdc
Input Impedance	500kΩ or more (1-5V) 250Ω (4-20mA)	1MΩ or more
Resolution	1 - 5V : 0 - 4000 4 - 20mA : 0 - 4000	-10V - +10V : -2000 - +2000
Overall Accuracy	±0.5%FS/25°C ±1%FS /0 - 55°C	±0.5%FS/25°C ±1%FS /0 - 55°C
Conversion Cycle	Approx. 2.4ms/channel	Approx. 2.4ms/channel
Wire breakage detection	Only possible for 4 - 20mA	—
External Power Supply failure detection	available	—
Current consumption	50mA (5Vdc) or less	50mA (5Vdc) or less
Withstand voltage	1500Vac /1minute	1500Vac /1minute
External Power required	24Vdc±10%-50mA	24Vdc±10%-90mA
Weight	Approx. 250g	Approx. 250g

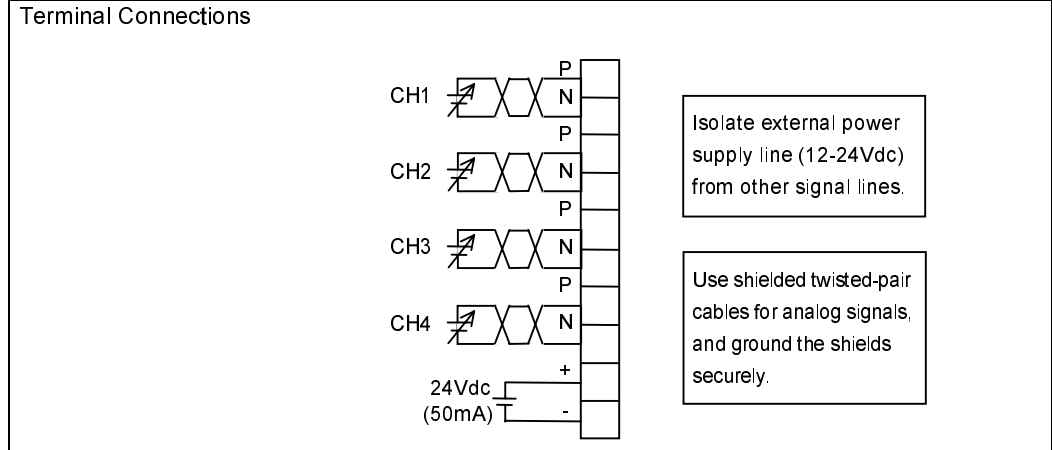
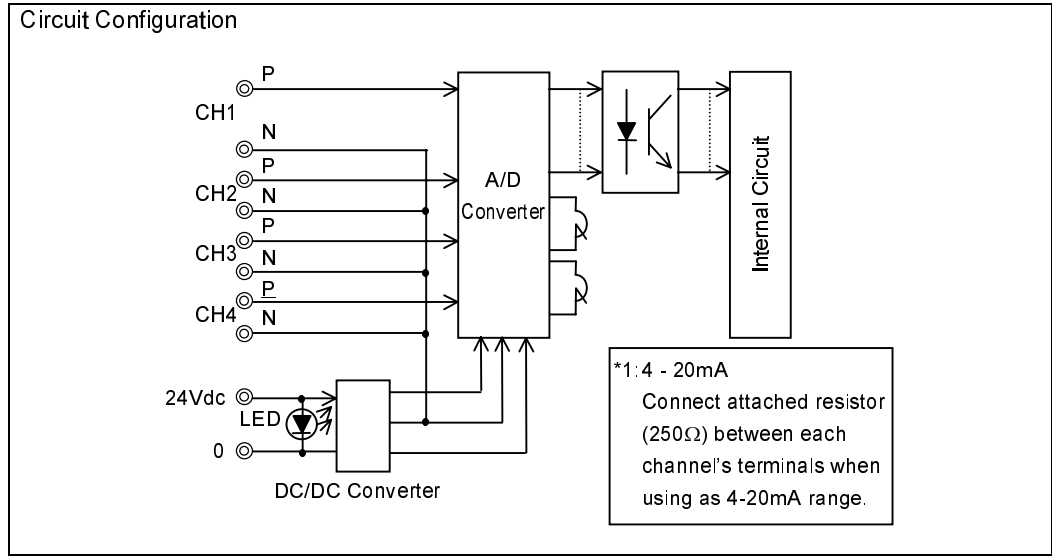

2

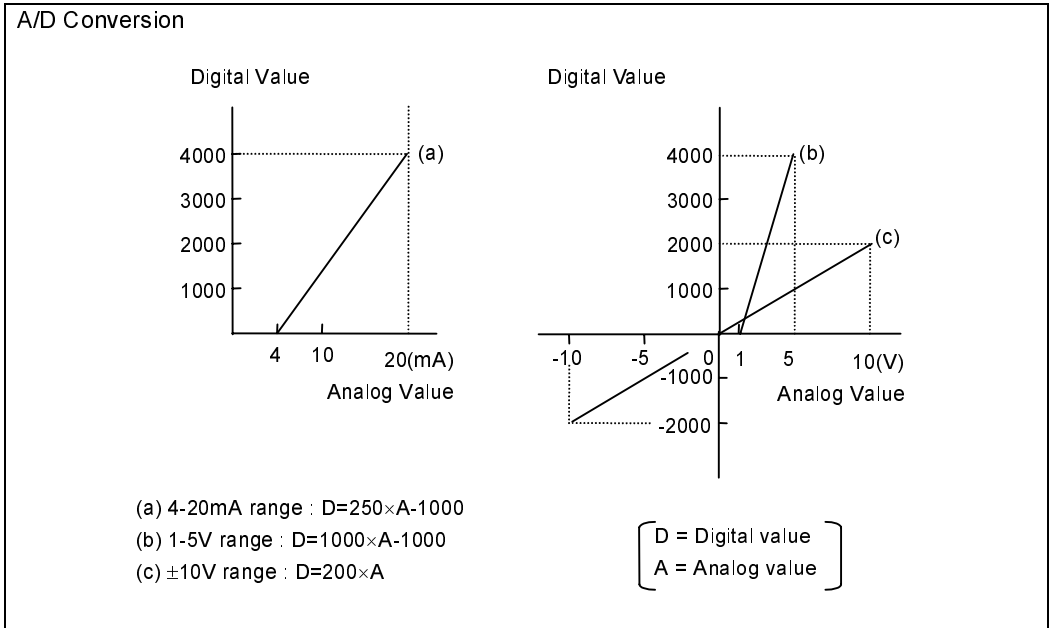

Data Format(Input 4 words)

- 1-5V/4-20mA

	F	E	D	C	B	A	9	8	7	6	5	4	3	2	1	0
XW	B	*	*	*	D	D	D	D	D	D	D	D	D	D	D	D

 - D: Data bit (12 bits)
0-4000 (H0000-H0FA0)
 - B: External line abnormal detection bit
0= Normal
1= Abnormal
(Current input line open, or external power OFF)
 - *: Always 0
- $\pm 10V$

	F	E	D	C	B	A	9	8	7	6	5	4	3	2	1	0
XW	S	S	S	S	D	D	D	D	D	D	D	D	D	D	D	D

 - S: Sign bit
0= Positive
1= Negative
 - D: Data bit (11 bits)
-2000 – 2000 (HF830 - H07D0)
2's complement if negative

NOTE

1. In the voltage input specification, the data bits do not become 0 when there is an open circuit between the input terminals. (They become indeterminate between 0 and 4000.)
2. It is recommended that unused channels are shorted between the input terminals.

■ AD668

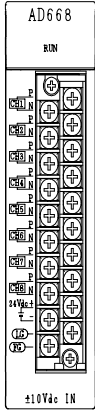

Item		Specification	
Module type		AD668	
Input type		Voltage input	Current input
Input range	Bipolar	-5 to +5V	
		-10 to +10V	
	Unipolar	0 to +5V	0 to 20mA
		0 to +10V	
	1 to +5V	4 to 20mA	
Input impedance		1MΩ or more	250Ω
Number of input channels		8channels per module	
Resolution		16 bits	
Overall accuracy (0 to 55°C)		±0.2%/FS (25°C) ±0.5%/FS (0 to 55°C) (FS : ±10V)	
Temperature drift		±100ppm/°C or less	
Conversion cycle		Approx. 1 ms/channel (Approx. 8ms/8channels)	
Insulation resistance		10MΩ or more	
Withstand voltage		1500Vac 1 minute : between internal and external, between analog input and FG/LG	
Special functions		Gain and offset adjust function Average value processing function Unassigned channel skip function External 24V power supply voltage drop error detection	
External power supply		24Vdc±10%	
Current consumption	Internal logic	5Vdc (300mA)	
	External power supply	24Vdc (120mA)	
External connection		20-point removable terminal block	
Weight		Approx. 300g	

2

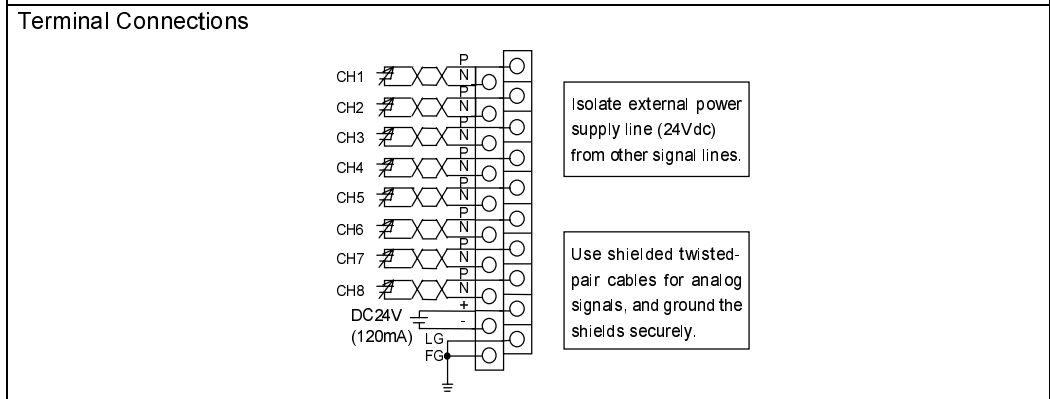
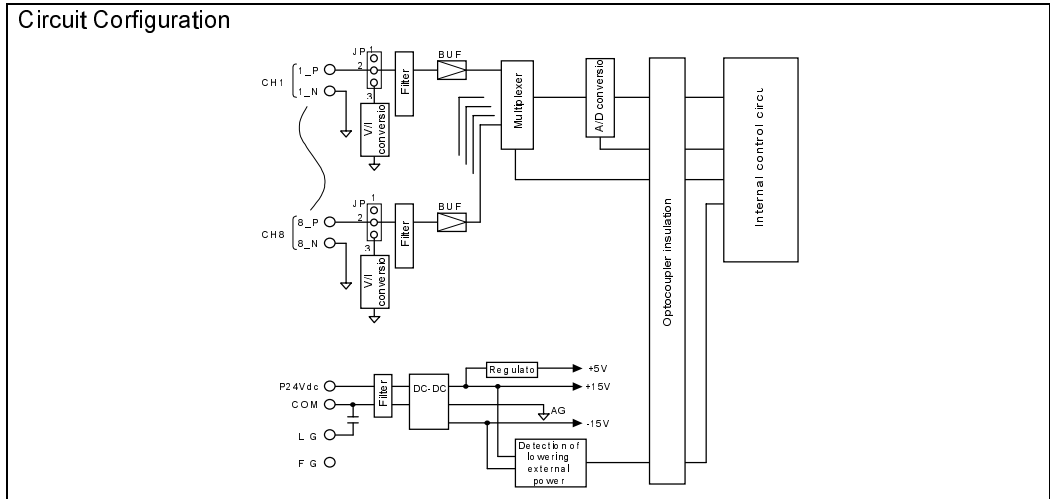

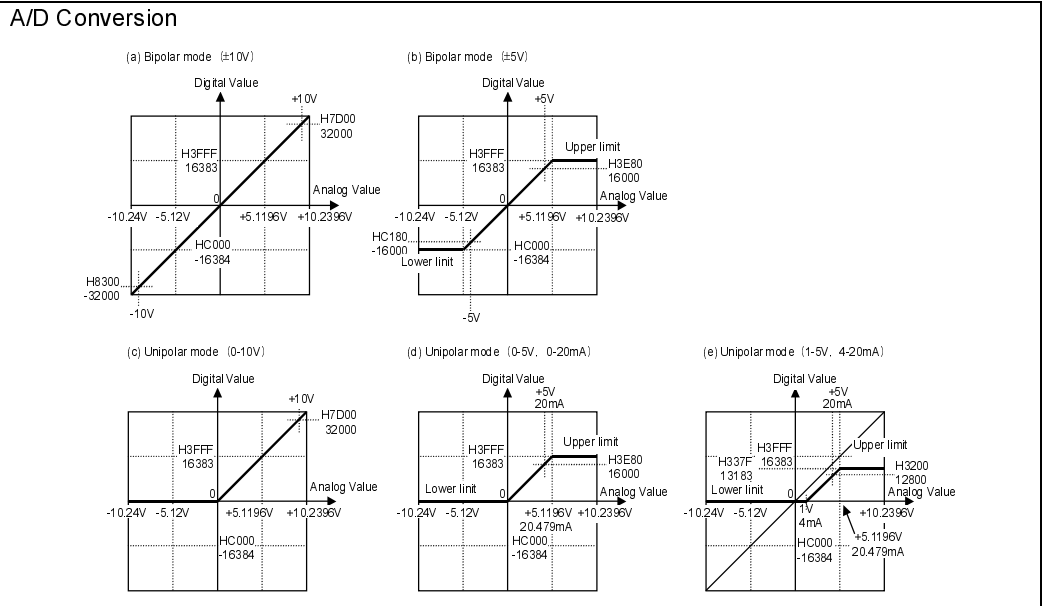

Data format (Input 8 words)

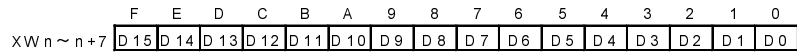

(a) Bipolar mode (± 10V)

	Analog input value		Analog conversion data			Resolution
	± 10V		Hexadecimal	Integer	Positive	
Upper limit (positive)	+10.2V		7F80H	32640	32640	0.3125mV/bit
Full scale (positive)	+10V		7D00H	32000	32000	
0	+0V		0000H	0	0	
Full scale (negative)	-10V		8300H	-32000	33536	
Lower limit (negative)	-10.2V		8080H	-32640	32896	

(b) Bipolar mode (± 5V)

	Analog input value		Analog conversion data			Resolution
	± 5V		Hexadecimal	Integer	Positive	
Upper limit (positive)	+5.1196V		3FFFH	16383	16383	0.3125mV/bit
Full scale (positive)	+5V		3E80H	16000	16000	
0	+0V		0000H	0	0	
Full scale (negative)	-5V		C180H	-16000	49536	
Lower limit (negative)	-5.12V		C000H	-16384	49152	

(c) Unipolar mode (0-10V)

	Analog input value		Analog conversion data			Resolution
	0 to 10V		Hexadecimal	Integer	Positive	
Upper limit (positive)	+10.2V		7F80H	32640	32640	0.3125mV/bit
Full scale (positive)	+10V		7D00H	32000	32000	
0	+0V		0000H	0	0	

(d) Unipolar mode (0-5V, 0-20mA)

	Analog input value		Analog conversion data			Resolution
	0 to 5V	0 to 20mA	Hexadecimal	Integer	Positive	
Upper limit (positive)	+5.1196V	+20.478mA	3FFFH	16383	16383	0.3125mV/bit 1.25µA/bit
Full scale (positive)	+5V	+20mA	3E80H	16000	16000	
0	+0V	+0mA	0000H	0	0	

(e) Unipolar mode (1-5V, 4-20mA)

	Analog input value		Analog conversion data			Resolution
	1 to 5V	4 to 20mA	Hexadecimal	Integer	Positive	
Upper limit (positive)	+5.1196V	+20.478mA	337FH	13183	13183	0.3125mV/bit 1.25µA/bit
Full scale (positive)	+5V	+20mA	3200H	12800	12800	
0	+1V	+4mA	0000H	0	0	

NOTE

For details, refer to the separate manual "High Function Analog Module User's Manual".

■ AD628S&AD638S



Item	AD628S	AD638S
Input Voltage/Amp	0-5V or 0-20mA (*1)	±10V
Input Impedance	500KΩ or more (0-5V) 250Ω (0-20m)	500KΩ or More
A/D Conversion Data	0-4000 min.0 max.4095	-2000-+2000 min.-2048 max.2047
Allowance Input Voltage/ Amp	At 0-5V: within ±13V 0-20mA: within ±30mA	Within ±13V
No. of Input Channel	8ch	
Resolution	12bit (0.25%)	
Conversion Time	2.0ms/8ch	
Overall Accuracy	±0.2% (at25°C) ±1.0% (0-55°C)	
Temperature Drift	±100ppm/°C	
Module Status Indicator	Power Source Indicator	
External Connection	18P Detachable Screw Terminal Table	
Mode of Insulation	Transformer Insulation (Insulation of Channels, Insulation between Input Circuit-Inside Logic)	
Insulation Resistance	10MΩ or More <ul style="list-style-type: none"> Between Inside logic-Output Between Systems 	
Withstand Voltage	AC500V/1min <ul style="list-style-type: none"> Between Inside Logic-External Output Between Systems 	
External Power Supply	Not Required	
Inside Current Consumption	600mA (at DC5V) or less	
Weight	Approx. 350g	

(*1) Selection between 0-5V and 4-20mA is done by desorbing 250Ω resistor (attached).
 Resistor installed: Current Input
 Resistor not installed: Voltage Input

Circuit Configuration

Terminal Connections

Use shielded twisted-pair cables for analog signals, and ground the shields securely.

Data Format (Input 8 words)
 (1)AD628S

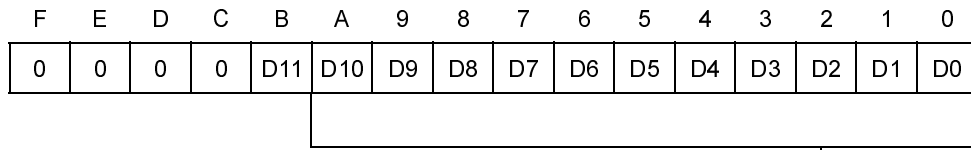

	Analog value		Digital value	
	0-5V	0-20mA	Hexadecimal value	Integer
Upper limit	5.11875V	20.475mA	0FFFH	4095
Full scale	5.000V	20.000mA	0FA0H	4000
Zero (lower limit)	0V	0mA	0000H	0
Analog input value per count	1.25mV	5μA		

(2)AD638S

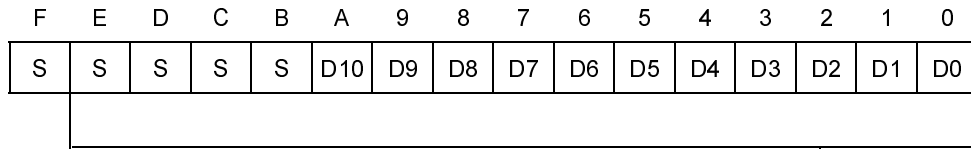

S: sign bit
 { Negative: "1"
 { Positive: "0"

Input	Analog value	Digital value	
		Hexadecimal value	Integer
Upper limit	+10.235V	07FFH	2047
Full scale (positive)	+10.000V	07D0H	2000
0	0V	0000H	0
Full scale (negative)	-10.000V	F830H	-2000
Lower limit	-10.24V	F800H	-2048
Analog input value per count	5mV		

2

■ TC618

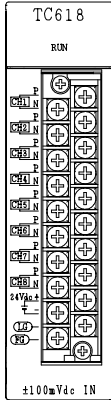

Item		Specification			
Module type		TC618			
Input type		Voltage input			
Input range	mV input	K thermo-couple	J thermo-couple	E thermo-couple	
	-100 to +100mV	-200 to +1200°C	-200 to +800°C	-200 to +600°C	
Number of input channels		8 channels	7 channels	7 channels	7 channels
Input impedance		1MΩ or more			
Resolution		16-bit			
Overall accuracy		±0.2%/FS (25°C)			
		±0.5%/FS (0 to 55°C) (FS: ±100mV)			
Temperature drift		±100ppm/°C or less			
Conversion cycle Approx		Approx. 1ms/ch (Approx. 8ms/8 channels)			
Insulation resistance		10MΩ or more			
Withstand voltage		1500Vac 1 minute : between internal and external, between analog input and FG/LG			
Special functions		Gain and offset adjust function (except the time when thermo-couple is input) Average value processing function Linearize function (when thermo-couple is input) Cold junction compensation function (when thermo-couple is input) Burnout function (when thermo-couple is input) External 24V power supply voltage drop error detection			
External power supply		24Vdc±10%			
Current consumption	Internal logic	5Vdc (300mA)			
	External power supply	24Vdc (120mA)			
External connection		20-point removable terminal block			
Weight		Approx. 300g			

2

Circuit Configuration

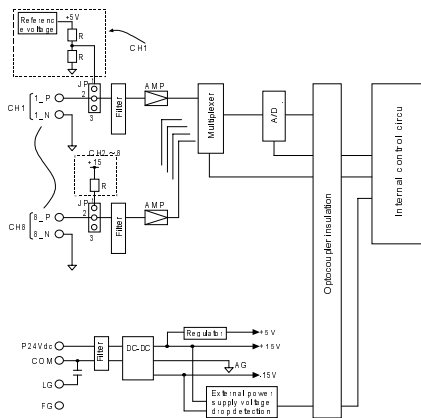

Terminal Connections

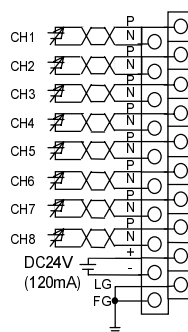

Isolate external power supply line (124Vdc) from other signal lines.

Use shielded twisted pair cables for analog signals, and ground the shields securely

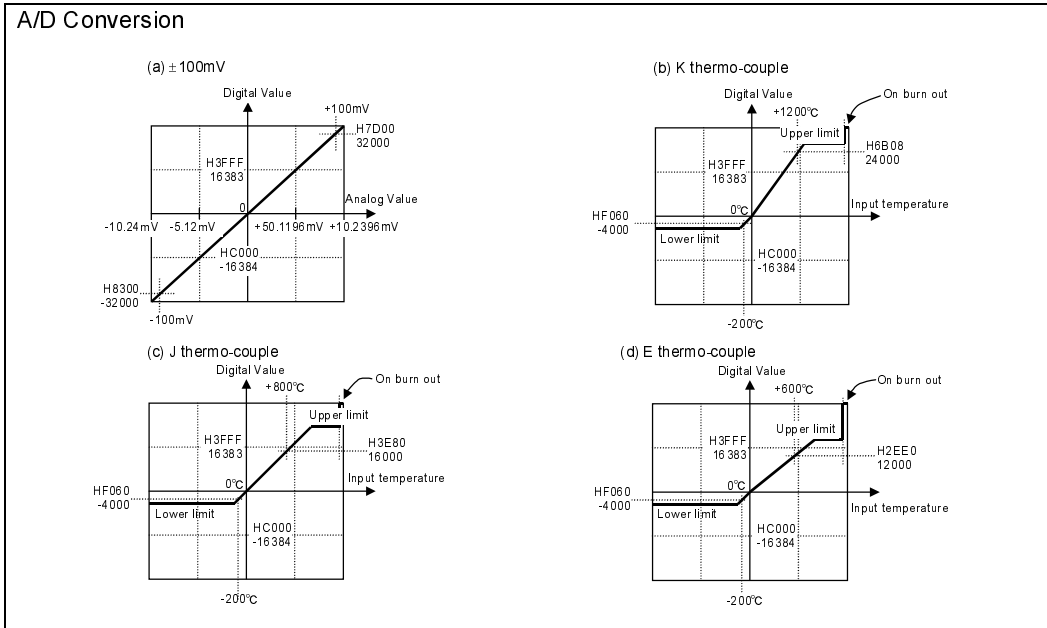

Data format (Input 8 words)

F E D C B A 9 8 7 6 5 4 3 2 1 0
 XW n ~ n+7 D15D14D13D12D11D10D9D8D7D6D5D4D3D2D1D0

(a) $\pm 100\text{mV}$

	Analog input value	Analog conversion data			Resolution
		$\pm 100\text{mV}$	Hexadecimal	Integer	
Upper limit (positive)	+102 mV	7F80H	32640	32640	3.125 $\mu\text{V}/\text{bit}$
Full scale (positive)	+100 mV	7D00H	32000	32000	
0	+0V	0000H	0	0	
Full scale (negative)	-100 mV	8300H	-32000	33536	
Lower limit (negative)	-102 mV	8080H	-32640	32896	
On burnout	Thermo-couple disconnected	7FFFH	32767	32767	

(b) K thermo-couple

	Input temperature	Analog conversion data			Resolution
		Hexadecimal	Integer	Positive	
Upper limit (positive)	+1370 °C	6B08H	27400	27400	0.05 °C / bit
Full scale (positive)	+1200 °C	5DC0H	24000	24000	
0	0 °C	0000H	0	0	
Full scale (negative)	-200 °C	F060H	-4000	61536	
Lower limit (negative)	-270 °C	EAE8H	-5400	60136	
On burnout	Thermo-couple disconnected	7FFFH	32767	32767	

(c) J thermo-couple

	Input temperature	Analog conversion data			Resolution
		Hexadecimal	Integer	Positive	
Upper limit (positive)	+1200 °C	5DC0H	24000	24000	0.05 °C / bit
Full scale (positive)	+800 °C	3E80H	16000	16000	
0	0 °C	0000H	0	0	
Full scale (negative)	-200 °C	F060H	-4000	61536	
Lower limit (negative)	-210 °C	EF98H	-4200	61336	
On burnout	Thermo-couple disconnected	7FFFH	32767	32767	

(d) E thermo-couple

	Input temperature	Analog conversion data			Resolution
		Hexadecimal	Integer	Positive	
Upper limit (positive)	+1000 °C	4E20H	20000	20000	0.05 °C / bit
Full scale (positive)	+600 °C	2EE0H	12000	12000	
0	0 °C	0000H	0	0	
Full scale (negative)	-200 °C	F060H	-4000	61536	
Lower limit (negative)	-270 °C	EAE8H	-5400	60136	
On burnout	Thermo-couple disconnected	7FFFH	32767	32767	

NOTE
 For details, refer to the separate manual "High Function Analog Module User's Manual".

■ RT614

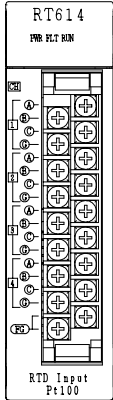

Item	Specification	Remarks
Input type	Resistance Temperature Detector input	
Input specification	Pt100	Comforms to JIS C 1604
Wire connection	3-wire system	
Input temperature range	-50°C to +270°C	Linear calibration range
Digital conversion	800 to 4000 counts	
Input channel	4 channels/module	
Insulation system	Optocoupler insulation	Non-insulation between channels
Conversion time	200ms/4ch	
Resolution	0.1°C/count	12 bits/0.025%
Overall accuracy	±0.3% (at 25°C)	
Withstand voltage	±100ppm/°C	
Withstand voltage	500Vac— 1 minute	
Current consumption	500mA (5Vdc)	
Weight	Approx. 300g	

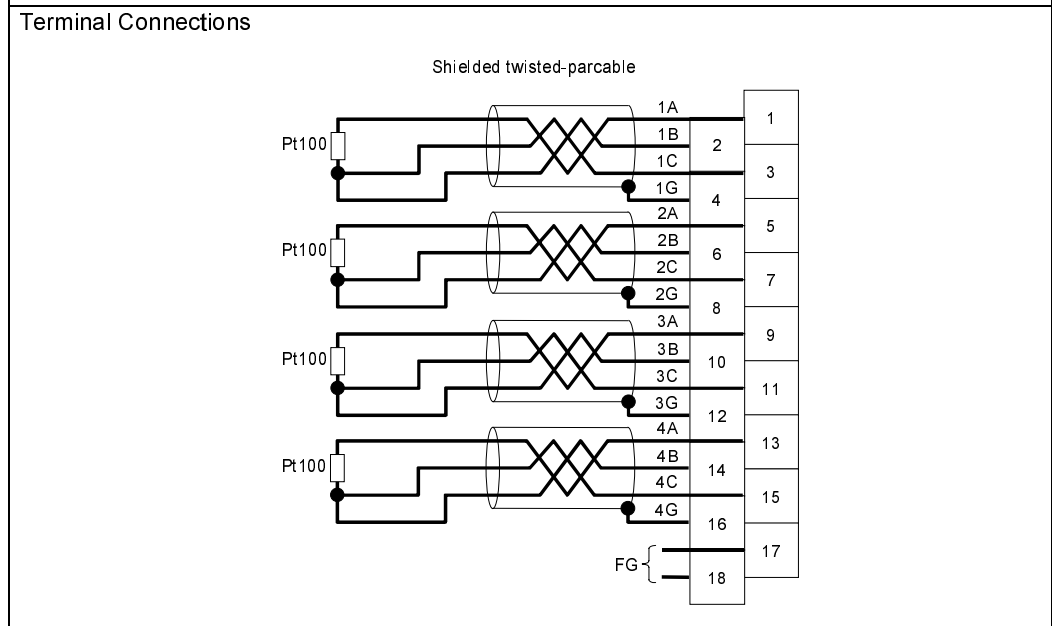
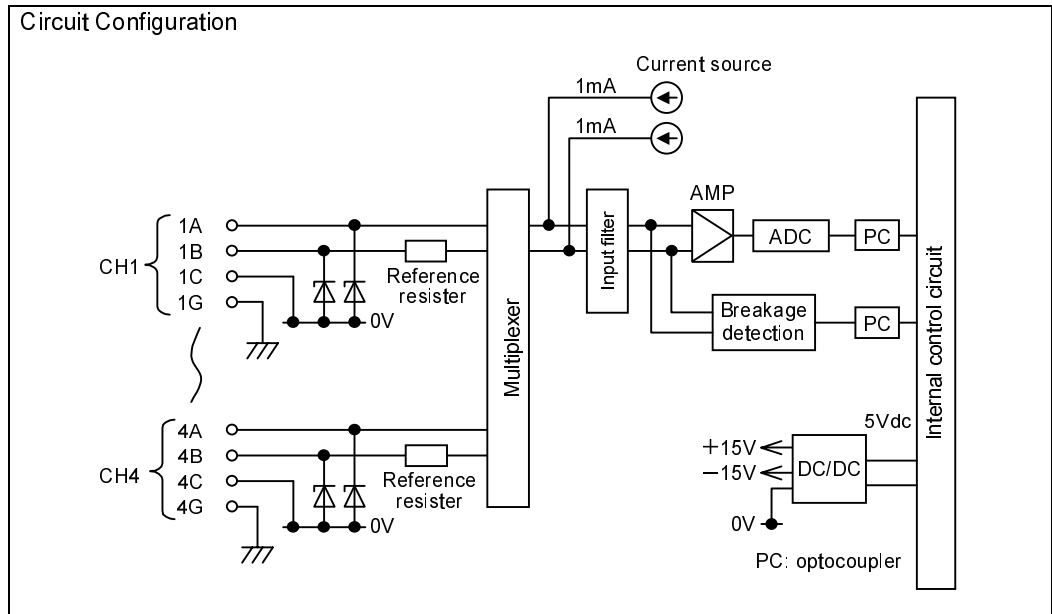

2

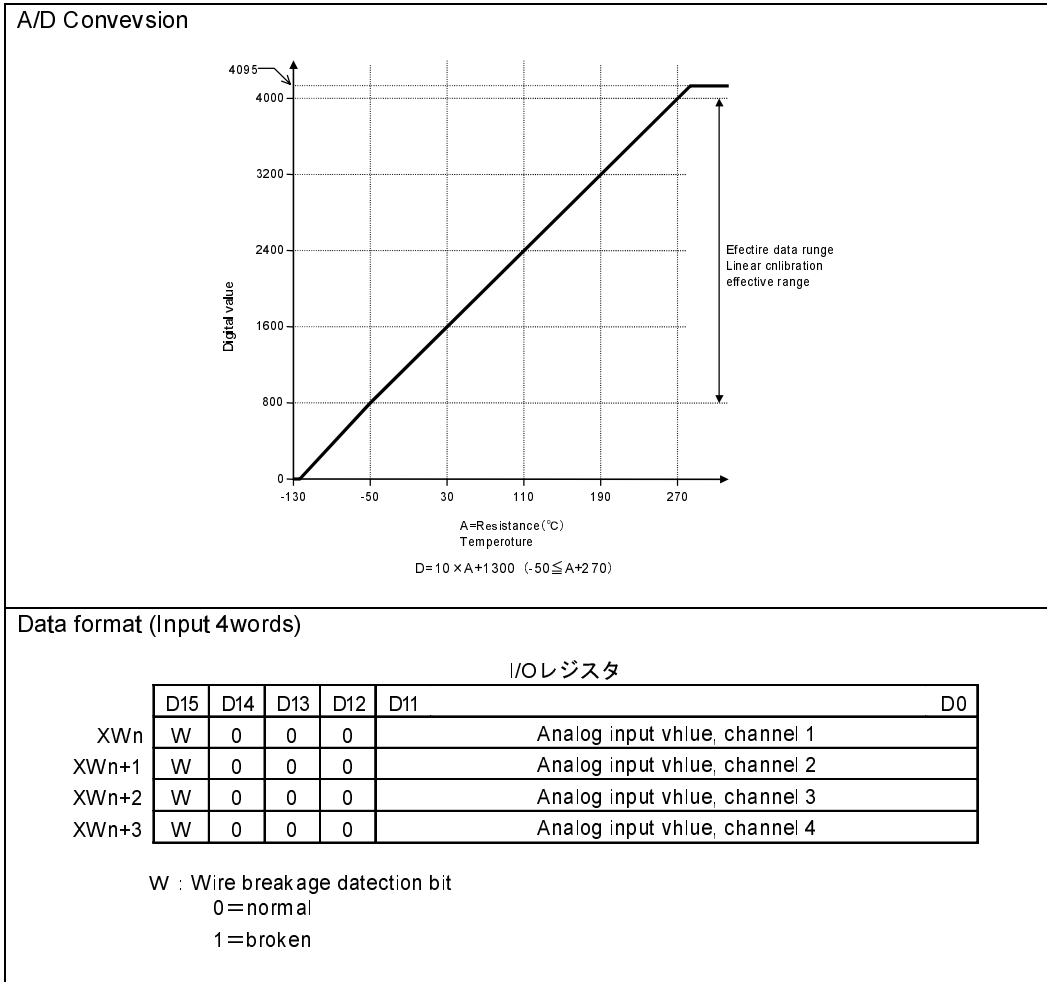

NOTE

For details, refer to the separate maunal "High Function Analog Module User's Manual".

■ DA664

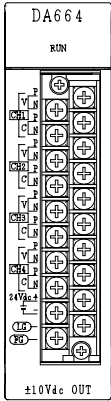

Item		Specification	
Module type		DA664	
Output type		Voltage output	Current output
Output range	Bipolar	-5 to +5V	
		-10 to +10V	
	Unipolar	0 to +10V	0 to 20mA
		1 to +5V	4 to 20mA
Output impedance		1k or more	600Ω or less
Number of output channels		4 channels per module	
Resolution		16 bits	
Overall accuracy		±0.2%/FS (25°C) ±0.5%/FS (0 to 55°C) (FSΔF±10V)	
Temperature drift		±100ppm/°C or less	
Conversion cycle		Approx. 1 ms/ch (Approx. 4ms/4 channels)	
Insulation resistance		500Vac-1 minute	
Insulation resistance		100MΩ or more	
Withstand voltage		1500Vac 1 minute : between internal and external, between analog input and FG/LG	
Special functions		Offset adjust protection Output hold / clear mode External 24V power supply voltage drop error detection	
External power supply		24Vdc±10%	
Current consumption	Internal circuit	5Vdc (230mA)	
External connection		20-point removable terminal block	
Weight		Approx. 300g	

2

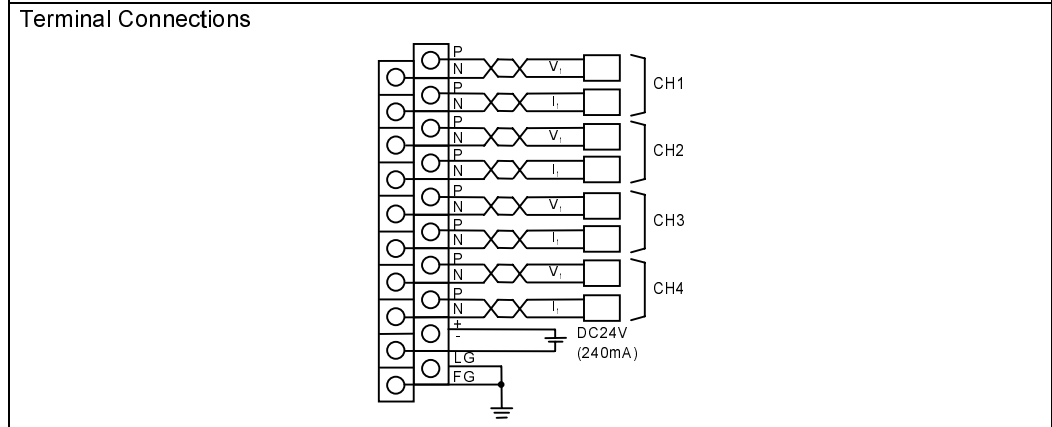
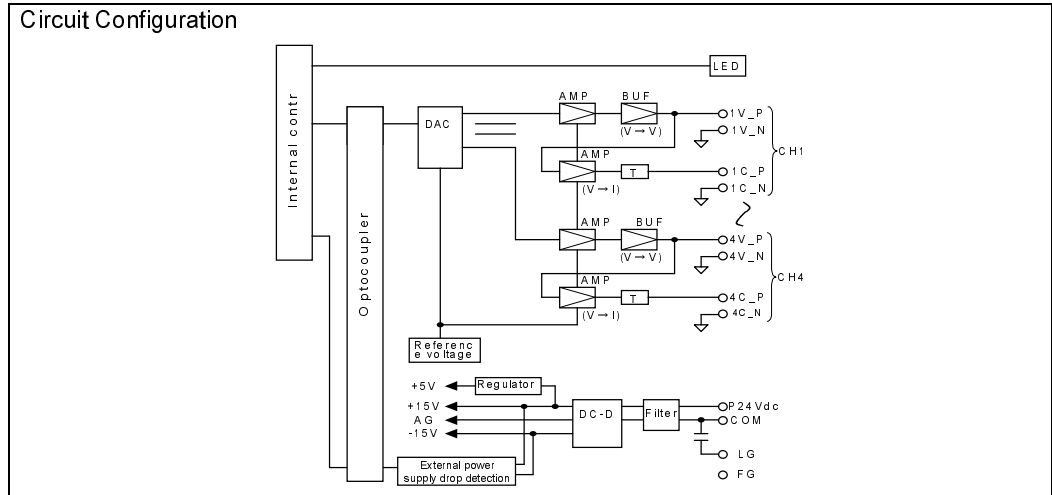

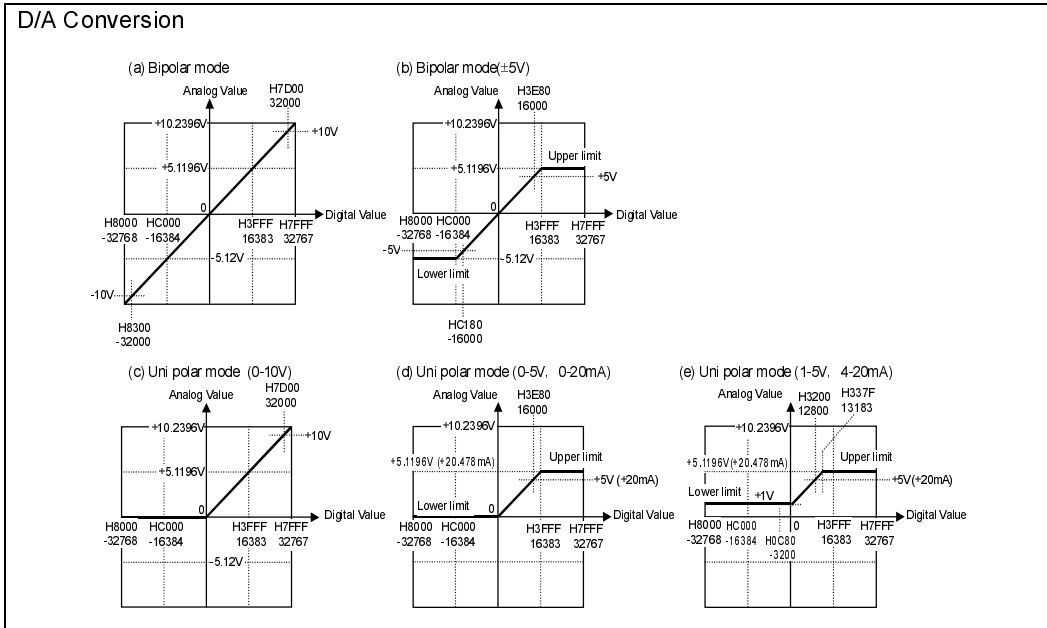

Data format (Input 4 words)

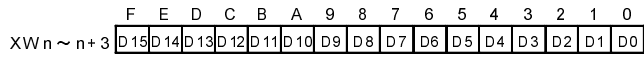

(a) Bipolar mode (±10V)

	Analog input value		Analog conversion data			Resolution
	±10V	Hexadecimal	Integer	Positive		
Upper limit (positive)	+10.2396V	7FFFH	32767	32767	0.3125m V/bit	
Full scale (positive)	+10V	7D00H	32000	32000		
0	+0V	0000H	0	0		
Full scale (negative)	-10V	8300H	-32000	33536		
Lower limit (negative)	-10.24V	8000H	-32768	32768		

(b) Bipolar mode (±5V)

	Analog input value		Analog conversion data			Resolution
	±5V	Hexadecimal	Integer	Positive		
Upper limit (positive)	+5.1196V	3FFFH	16383	16383	0.3125m V/bit	
Full scale (positive)	+5V	3E80H	16000	16000		
0	+0V	0000H	0	0		
Full scale (negative)	-5V	C180H	-16000	49536		
Lower limit (negative)	-5.12V	C000H	-16384	49152		

(c) Unipolar mode (0-10V)

	Analog input value		Analog conversion data			Accuracy/bit
	0~10V	Hexadecimal	Integer	Positive		
Upper limit (positive)	+10.2396V	7FFFH	32767	32767	0.3125m V/bit	
Full scale (positive)	+10V	7D00H	32000	32000		
0	+0V	0000H	0	0		

(d) Unipolar mode (0-5V, 0-20mA)

	Analog input value		Analog conversion data			Resolution
	0~5V	0~20mA	Hexadecimal	Integer	Positive	
Upper limit (positive)	+5.1196V	+20.478mA	3FFFH	16383	16383	0.3125m V/bit 1.25µA/bit
Full scale (positive)	+5V	+20mA	3E80H	16000	16000	
0	+0V	+0mA	0000H	0	0	

(e) Unipolar mode (1-5V, 4-20mA)

	Analog input value		Analog conversion data			Resolution
	1~5V	4~20mA	Hexadecimal	Integer	Positive	
Upper limit (positive)	+5.1196V	+20.478mA	337FH	13183	13183	0.3125m V/bit 1.25µA/bit
Full scale (positive)	+5V	+20mA	3200H	12800	12800	
0	+0V	+4mA	0000H	0	0	

NOTE

For details, refer to the separate maunal "High Function Analog Module User's Manual".

■ DA622L

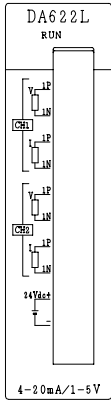

Item	DA622L
No. of output channel	2 channels (N side common)
Output Range	1-5V, 4-20mA (paired output)
Load Impedance	5V full-scale terminal : 5KΩ or more 20mA full-scale terminal : 600Ω or more
Resolution	1-5V, 4-20mA: 0-250
Overall Accuracy	±0.5%FS/25°C ±1%FS/0~55°C
Conversion Cycle	Approx. 1ms/channel
External Power Supply failure detection	None
Current consumption	70mA (5Vdc) or less
Withstand voltage	1500Vac /1minute
External Power required	24Vdc±10%-90mA
Weight	Approx. 250g

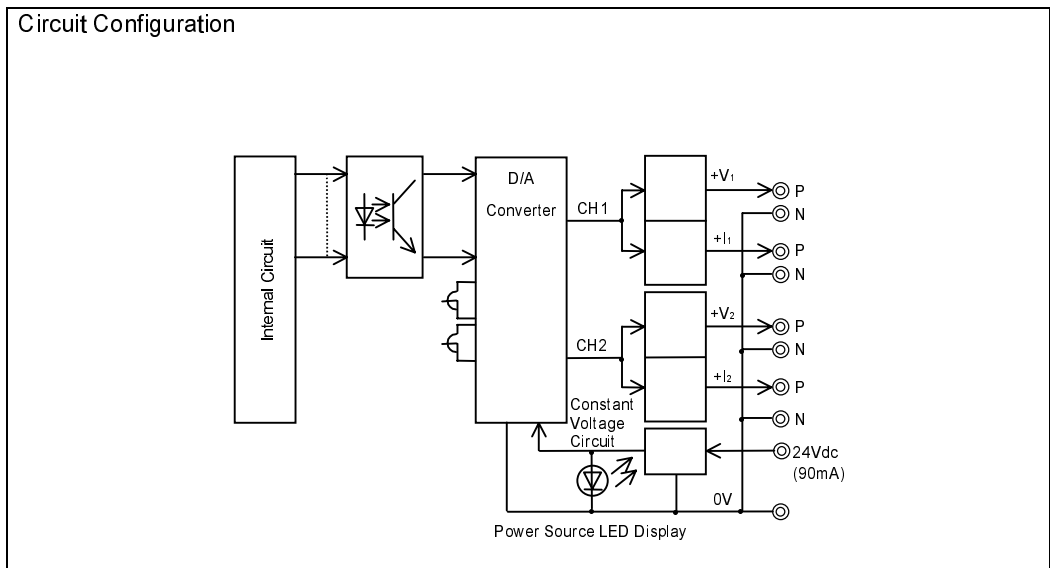

2

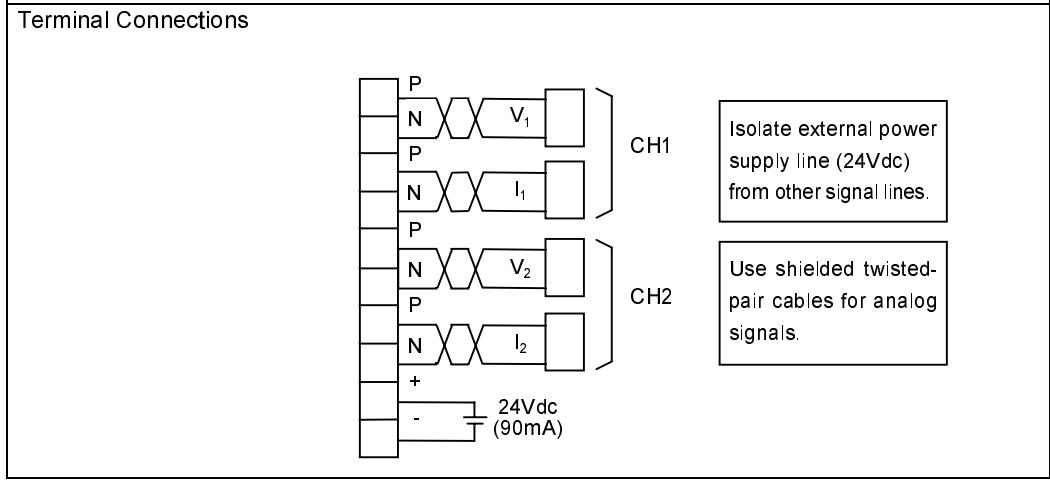

D/A Conversion

Analog Value (mA)

Analog Value (V)

(a) 4-20mA range : $A=0.064 \times D+4$
 (b) 1-5V range : $A=0.016 \times D+1$
 (c) 0-10V range : $A=0.04 \times D$

A = Analog Value
D = Digital Value

Data Format

	F	E	D	C	B	A	9	8	7	6	5	4	3	2	1	0
YW	*	*	*	*	*	*	*	*	D	D	D	D	D	D	D	D

D: Data bit (8 bits)
0-250 (H00-HFA)
*: No effect (No effect on D/A conversion)

2 words occupied
(Y2W)

{

YWn

YWn+1

}

F	0
CH1	
CH2	

NOTE

Two output registers (both channels) should be specified to output when executing direct output.

■ DA622&DA672

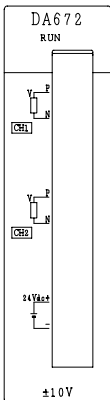
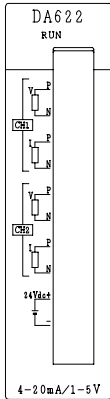

Item	DA622	DA672
No. of output channel	2 channels (N side common)	2 channels (N side common)
Output Range	1-5V, 4-20mA (paired output)	-10 - +10V
Load Impedance	1-5V:5KΩ or more 4-20mA:600Ω or more	5KΩ or more
Resolution	1-5V, 4-20mA: 0-4000	-10V- +10V:-2000 - +2000
Overall Accuracy	±0.5%FS/25°C ±1%FS/0~55°C	±0.5%FS/25°C ±1%FS/0~55°C
Conversion Cycle	Approx. 1ms/channel	Approx. 1ms/channel
External Power Supply failure detection	None	None
Current consumption	170mA (5Vdc) or less	170mA (5Vdc) or less
Withstand voltage	1500Vac /1minute	1500Vac /1minute
External Power required	24Vdc±10%-90mA	24Vdc±10%-90mA
Weight	Approx. 250g	Approx. 250g

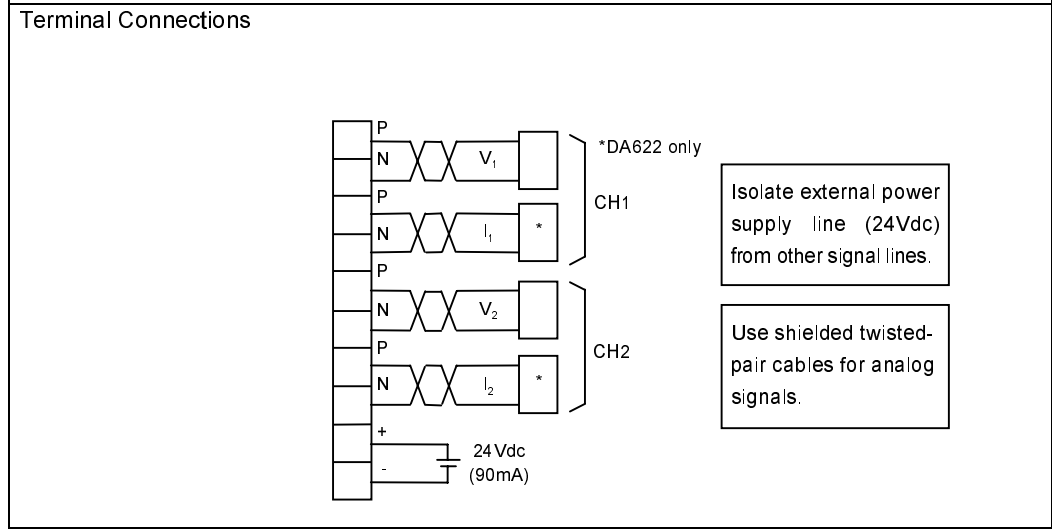
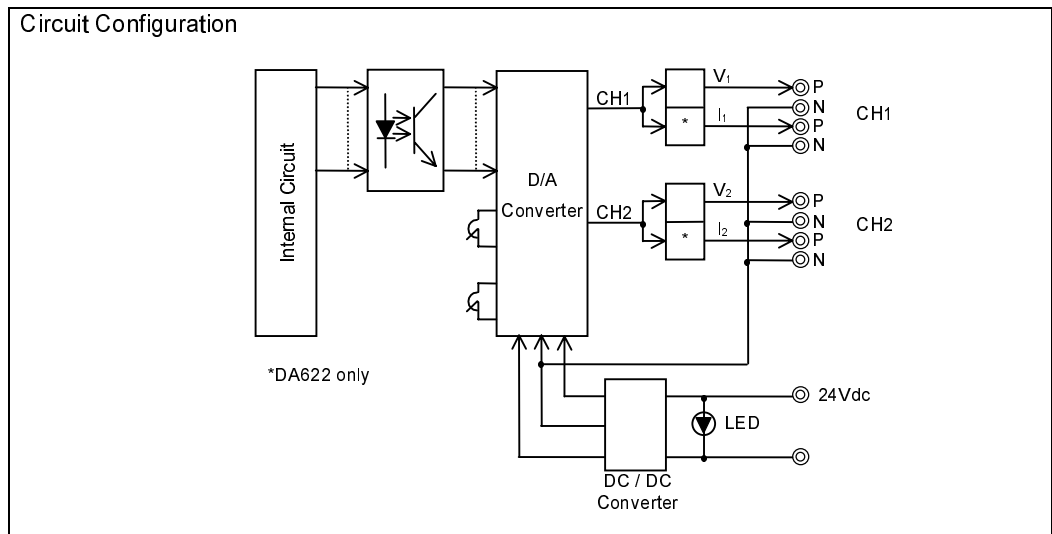

2

D/A Conversion

Analog Value (mA)

Analog Value (V)

(a) 4-20mA range : $A=0.004 \times D+4$
 (b) 1-5V range : $A=0.001 \times D+1$
 (c) $\pm 10V$ range : $A=0.005 \times D$

A = Analog Value
D = Digital Value

Data Format (Output occupies 2 words)

- 4-20mA / 1-50

	F	E	D	C	B	A	9	8	7	6	5	4	3	2	1	0
YW	*	*	*	*	D	D	D	D	D	D	D	D	D	D	D	D

D: Data bit (12 bits)
0-4000 (H0000-H0FA0)
*:No effect (No effect on D/A conversion)
- $\pm 10V$

	F	E	D	C	B	A	9	8	7	6	5	4	3	2	1	0
YW	*	*	*	*	S	D	D	D	D	D	D	D	D	D	D	D

S: Sign bit
0 = Positive
1 = Negative
D: Data bit (11 bits)
-2000 – 2000 (HF830 - H07D0)
2's complement if negative

NOTE

Two output registers (both channels) should be specified to output when executing direct output.

■ CF611

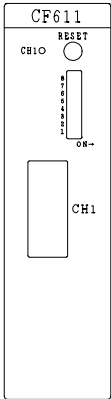

Item	CF611
Function	Communicate with the devices via serial interface
Common memory	160 words × 2
Transmission mode	Full-duplex
Synchronization	Asynchronous (Start-stop method)
Transmission Speed	300, 600, 1200, 2400, 4800, 9600, 19200bps
Transmission code	ASCII
Interface	Conforms to RS232C 1 channel
Frame Format	Start bit : 1bit Data : 7 or 8bits Parity bit : even/odd/none When none parity is selected, the data bit length must be 8 bits. Stop bit : 1 or 2bits When 2 stop bits is selected, the data bit length must be 7 bits.
I/O occupancy area	X+YW 4W aera (Input prohibit/Output prohibit)
Data exchange method	By MREAD/MWRITE instructions of the S2T
LED Display	Transmission data
Isolation	None (between RS232C port and internal circuit)
Current consumption	550mA (5Vdc) or less
Weight	Approx. 300g

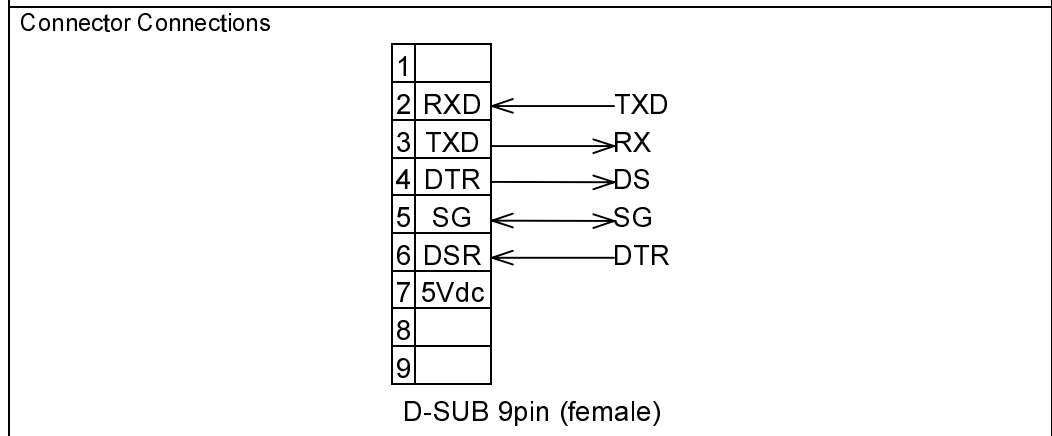
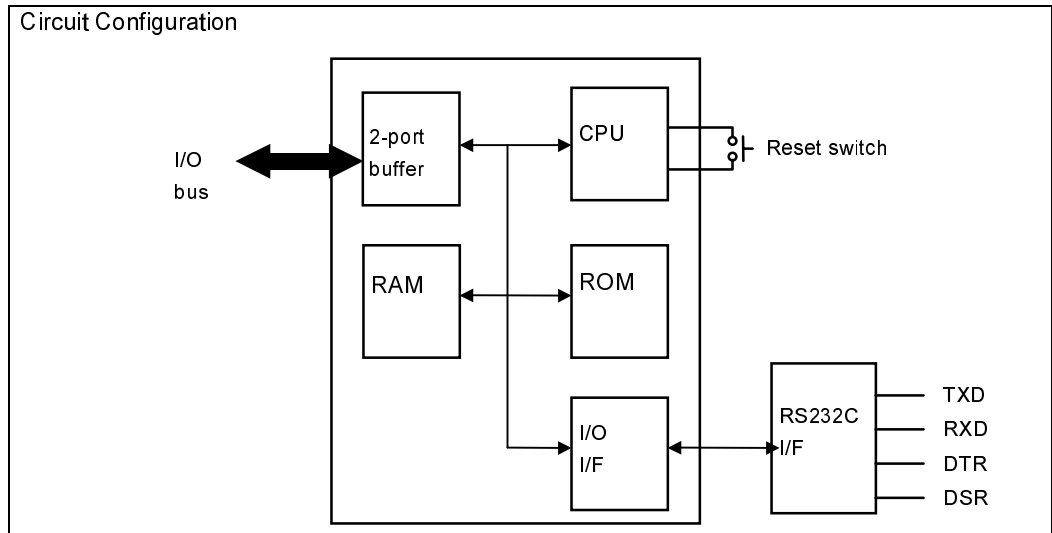

2

■ PI632&PI672

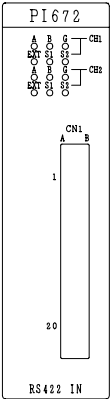
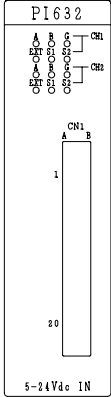

Item		PI632			PI672		
No. of pulse input channel		2 channels			2 channels		
I/O allocation type		X+YW 4W area (input/output inhibit) and 19W memory					
Input Voltage Range (A,B,M)		5V±5% /12V±5% /24V±5% (selectable)			Conforms to EIA RS-422-A		
Input Voltage Range (G,EXT)		12V±5% /24V±5%					
Input Spec. (A,B, M,G)	Input Voltage	5Vdc	12Vdc	24Vdc	RS422		
	Input current (typ.)	13mA	15mA	16mA	EIA standard RS-422-A Am26LS31		
	Minimum ON Voltage	3.75V or more	9.5V or more	21V or more			
	Maximum OFF Voltage	1.25V or less	2.5V or less	5V or less			
Input Spec. (EXT)	Input Voltage	12V/24Vdc					
	Input current (typ.)	10mA					
	Minimum ON Voltage	9.6V or more					
	Maximum OFF Voltage	3.5V or less					
Pulse duration (ON/OFF level)		5ms or more (other than quadrature bi-pulse) 10ms or more (quadrature bi-pulse)					
ON/OFF transition		1.5ms or less (other than quadrature bi-pulse) 3ms or less (quadrature bi-pulse)					
Counter configuration		24-bit, binary counter, Count value=0 to 16777215)					
Input pulse frequency		100kpps maximum (other than quadrature bi-pulse) 50kpps maximum (quadrature bi-pulse)					
Pulse count mode		Normal mode (1 count per 1 pulse) Precision count mode (both rising and falling edges)					
Hardware comparison output function		2 points for each channel (transistor output) *S1: ON when Count value > set-point 1 *S2: ON when Count value < set-point 2					
Output Spec.	Output Voltage	24Vdc (10Vdc~30Vdc)					
	Output current	100mA or less					
Withstand voltage		1500Vac /1minute			500Vac /1minute		
Current consumption		500mA(5Vdc) or less			650mA(5Vdc) or less		
Weight		Approx. 250g			Approx. 250g		

Connector Assignment

PI632

Function	Name	Pin No.		Name	Function
		A	B		
Channel 1 Phase A input	1A5	1	1	1A1	Channel 1 Phase A input
Channel 1 Phase B input	1B1	2	2	1A12	Channel 1 Phase B input
	1B12	3	3	1B5	
Channel 1 Maker input	1M1	4	4	1M5	Channel 1 Maker input
	1M12	5	5	2A1	Channel 2 Phase A input
Channel 2 Phase A input	2A5	6	6	2A12	
Channel 2 Phase B input	2B1	7	7	2B5	Channel 2 Phase B input
	2B12	8	8	2M1	Channel 2 Maker input
Channel 2 Maker input	2M5	9	9	2M12	
Channel 1 Gate input	1G1	10	10	1G5	Channel 1 Gate input
	1G12	11	11	2G1	Channel 2 Gate input
Channel 2 Gate input	2G5	12	12	2G12	
Channel 1 External limit input	1EXT-	13	13	1EXT+	Channel 1 External limit input
Channel 2 External limit input	2EXT-	14	14	2EXT+	Channel 2 External limit input
Channel 1 Compare output 2	1S2	15	15	1S1	Channel 1 Compare output 1
Channel 2 Compare output 2	2S2	16	16	2S1	Channel 2 Compare output 1
No use		17	17		No use
24 Vdc input	F24	18	18	F24	24 Vdc input
0V for compare outputs	N24	19	19	N24	0V for compare outputs
No use		20	20		No use

PI672

Function	Name	Pin No.		Name	Function
		A	B		
Channel 1 Phase A +	1A +	1	1	1A -	Channel 1 Phase A -
Channel 1 Phase B +	1B +	2	2	1B -	Channel 1 Phase B -
Channel 1 Maker +	1M +	3	3	1M -	Channel 1 Maker -
Channel 2 Phase A +	2A +	4	4	2A -	Channel 2 Phase A -
Channel 2 Phase B +	2B +	5	5	2B -	Channel 2 Phase B -
Channel 2 Maker +	2M +	6	6	2M -	Channel 2 Maker -
Line receiver signal ground	SG	7	7	SG	Line receiver signal ground
Channel 1 Gate input	1G24	8	8	1G12	Channel 1 Gate input
	1GP	9	9	2GP	Channel 2 Gate input
Channel 2 Gate input	2G12	10	10	2G24	
No use		11	11		No use
Channel 1 External limit input	1EXT-	12	12	1EXT+	Channel 1 External limit input
Channel 2 External limit input	2EXT-	13	13	2EXT+	Channel 2 External limit input
No use		14	14		No use
Channel 1 Compare output 2	1S2	15	15	1S1	Channel 1 Compare output 1
Channel 2 Compare output 2	2S2	16	16	2S1	Channel 2 Compare output 1
No use		17	17		No use
24 Vdc input	F24	18	18	F24	24 Vdc input
0V for compare outputs	N24	19	19	N24	0V for compare outputs
No use		20	20		No use

2

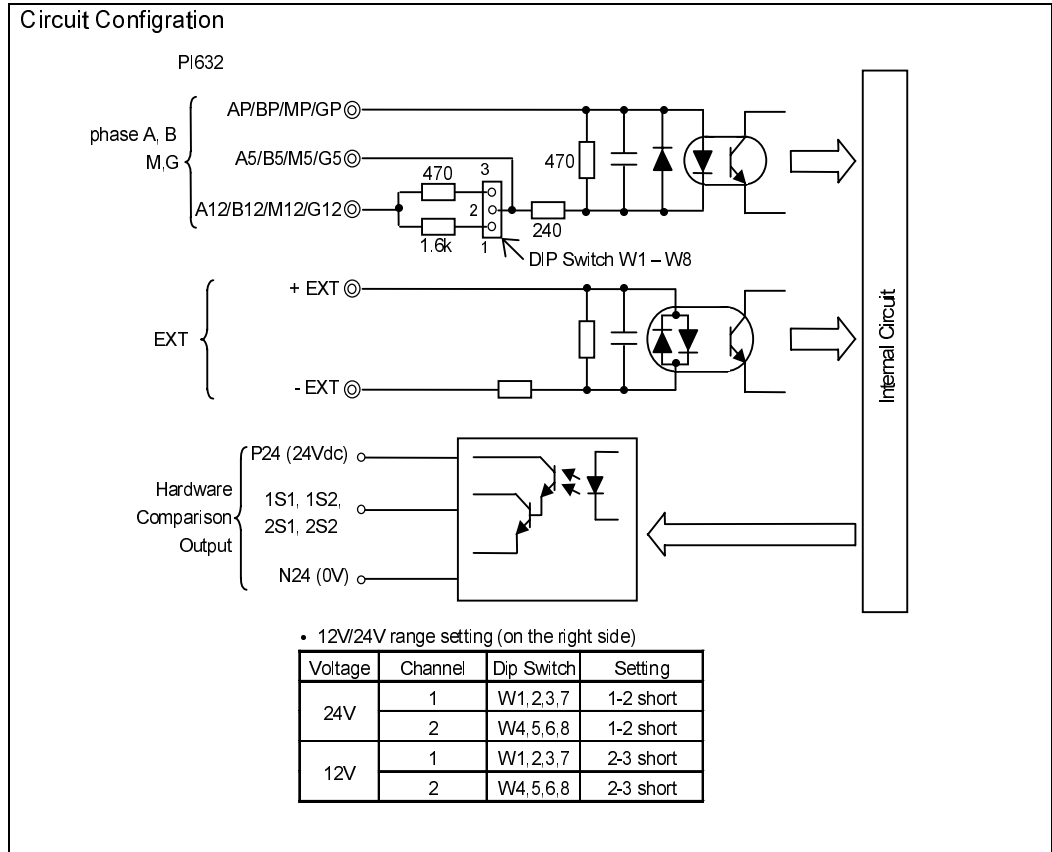

2

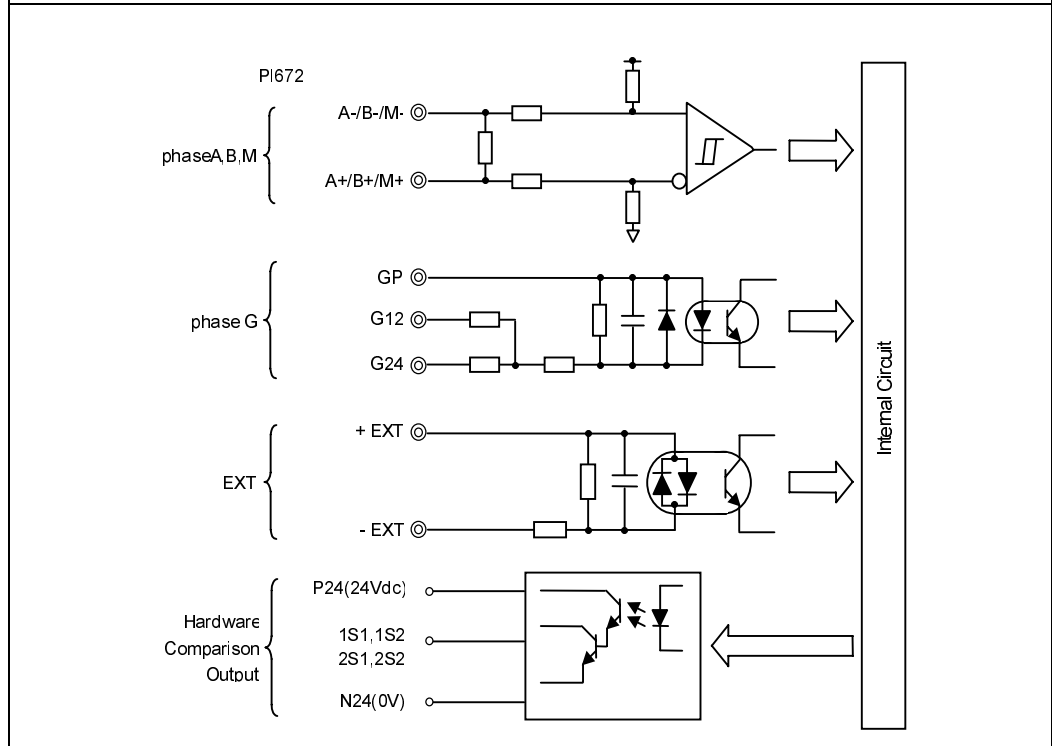

NOTE

- Connectors on the Module : FCN-365P040/AU (made by Fujitsu)
- Cable side connectors : Soldering type (standard attached)
- Connector : FCN-361J040-AU (made by Fujitsu)
- Connector cover : FCN-360C040-E (made by Fujitsu)

■ MC612

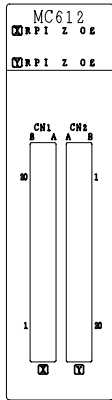

Item		Specifications		
Number of control axis		2axes (2 independent axis or 2 axes linear interpolation)		
Input command unit		pulse, inch, mm, etc		
Command value range		-9,999,999 to +9,999,999		
Command data capacity		30points / each axis		
Maximum speed		200kpps		
Acceleration / deceleration method		Automatic trapezoid / Triangular system		
Acceleration / deceleration rate		0 to 32.76 seconds		
Backlash compensation		0 to 1000 pulses		
Zero offset		-9,999,999 to +9,999,999		
Dwell time		0 to 100.00 seconds		
I/O points number		X+Y, 4 words		
Parameter data storage		FLASH-ROM		
Ext	LS, etc	Signal name	LS	In-position / Servo healthy
		Input voltage	12 / 24Vdc	24Vdc
		Input current	10mA (at 24Vdc)	
		ON / OFF voltage	9.6Vdc or less / 3.2 Vdc or more	
		ON / OFF delay	5msec. or less / 5msec. or less	
	Pulse / Z phase	Input voltage	5Vdc	
		Input current	16mA (at 5Vdc)	
		ON / OFF voltage	4.0Vdc or less / 1.2Vdc or more	
ON / OFF delay		1 μ sec. or less / 1μ sec. or less		
Ext	Pulse output	Mode	1. CW/CCW (positive / negative direction pulse), error counter clear. 2. PLS/DIR (pulse / direction), error counter clear.	
		Output system (Pulse output)	Open collector (5 - 24Vdc, 50mA) Line driver (RS485, max30mA)	
		ON / OFF delay	2 μ sec. / 2μ sec.	
		ON duty	40 to 60% (at maximum speed is 30kpps)	
	Other output	Output system	Open collector (5 - 24Vdc, 50mA)	
		ON / OFF delay	2msec. / 2msec.	
Power consumption	Internal	700mA (at 5Vdc)		
	External	200mA (at 24Vdc)		

Arrangement of connector pins			
A-side	Pin no.	B-side	
Overtravel limit input : CCW side	20	Overtravel limit input : CW side	
Zero position marker input	19	Emergency stop input	
Interrupt input (INT)	18	Speed / position changeover input	
NC	17	External input common (+ / -)	
NC	16	NC	
Servo healthy input	15	IN-position input	
Common for servo input (24Vdc)	14	Common for servo output (0V)	
Pulse enable output: CCW side	13	Pulse enable output: CW side	
Run control (servo ON) output	12	Reset output	
Error counter clear output	11	NC	
NC	10	NC	
CW pulse / A phase pulse input : + side	9	CW pulse / A phase pulse input : - side	
CCW pulse / B phase pulse input : + side	8	CCW pulse / B phase pulse input : - side	
Z phase pulse input : + side	7	Z phase pulse input : - side	
Pulse input / output GND (0V)	6	Pulse input / output GND (0V)	
CW pulse / pulse output (open collector)	5	CW pulse / pulse output (0V)	
CCW pulse / direction output (open collector)	4	CCW pulse / direction output (0V)	
CW pulse / pulse output (Line driver) : + side	3	CW pulse / pulse output (Line driver) : - side	
CCW pulse / direction output (Line driver) : + side	2	CCW pulse / direction output (Line driver) : - side	
External power supply (24Vdc) *1	1	External power supply (0V) *1	

NC : Not used pin. Do not wiring any external wire.

*1 : The pins of Y-axis are not used pin.

The X/Y-axis arrangement of connector pins are same without A1 or B1.

NOTE	
Module side connector	: FCN-361P040-AU-2 (MAKER : FUJITSU)
Cable side connector	: soldering type (standard attached)
External connector	: FCN-361J040-AU (Solder type)
Connector cover	: FCN-36C040-E

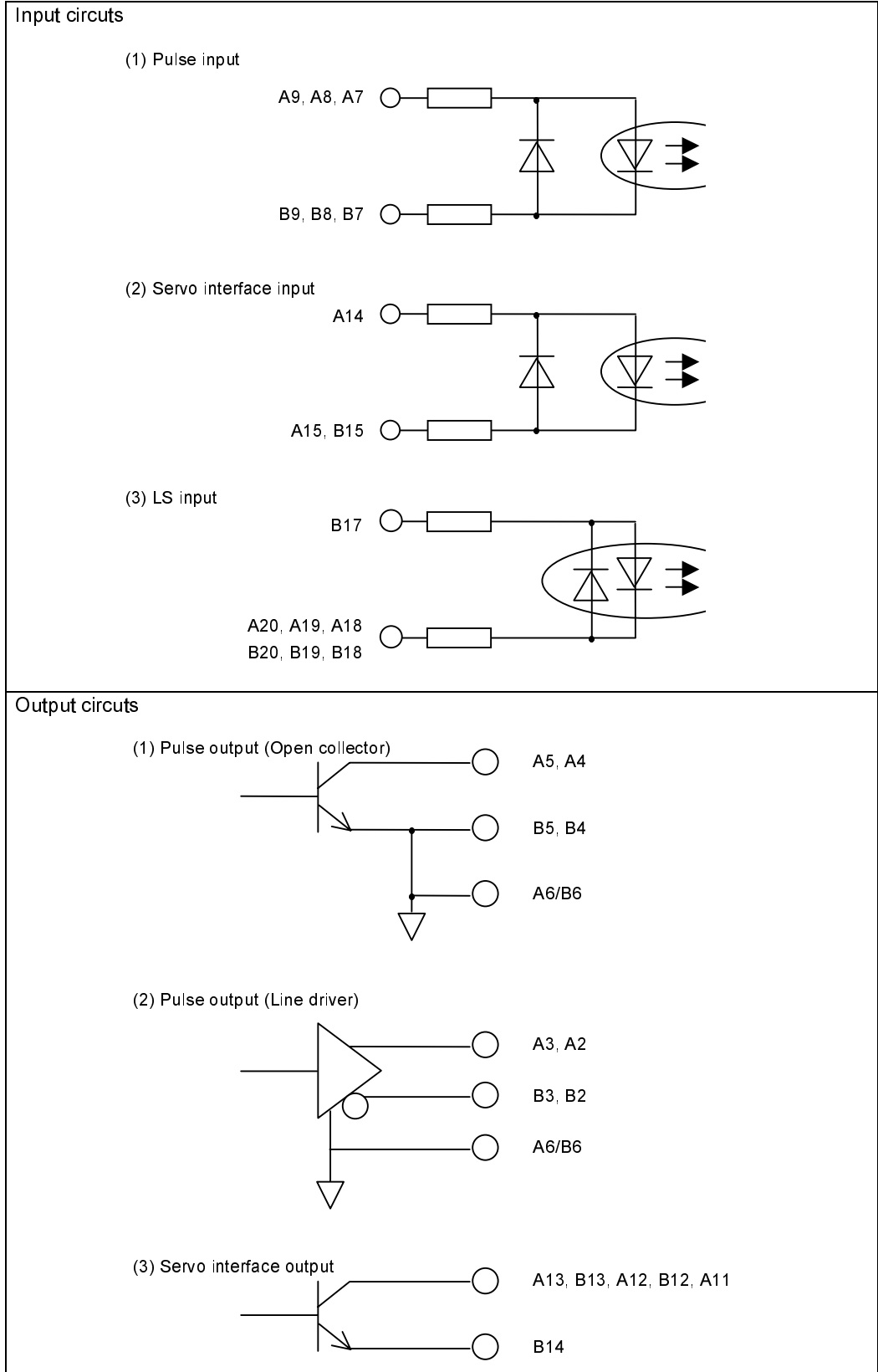

2

Chapt.3 Precautions for I/O Modules

3.1 Precautions for DC Input Modules

- (1) Read conditions for the ON/OFF changes of the input signals are :
 Input ON time \geq ON delay time (OFF \rightarrow ON)+Input reading cycle
 Input OFF time \geq OFF delay time (ON \rightarrow OFF)+Input reading time
 The "input reading cycle" means the S2T scan cycle for the refresh input, or the execution interval of a direct input instruction when the instruction is used.
- (2) For some external contacts, the input current (8mA/24V for DI633; 4mA/24V for DI634/635) of modules may not be able to maintain contact reliability. In the case, install a bleeder resistor between the input and common terminals to increase the contact current.

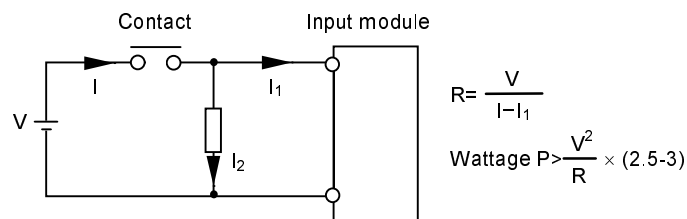

(An example of selecting a bleeder resistor R)
 Input Voltage V= 24Vdc
 Input module DI633(8mA/24Vdc)
 When the contact requires 50mA current ;

Resistance value R of a bleeder resistor
$$R = \frac{24[V]}{50[mA] - 8[mA]} = 0.6[K\Omega]$$

Wattage P of the bleeder resistor
$$P = \frac{24[V]}{(560[\Omega])} \times (2.5-3) \doteq 3[W]$$

- (3) The examples of connection with transistor output devices such as proximity switches are shown as follows.

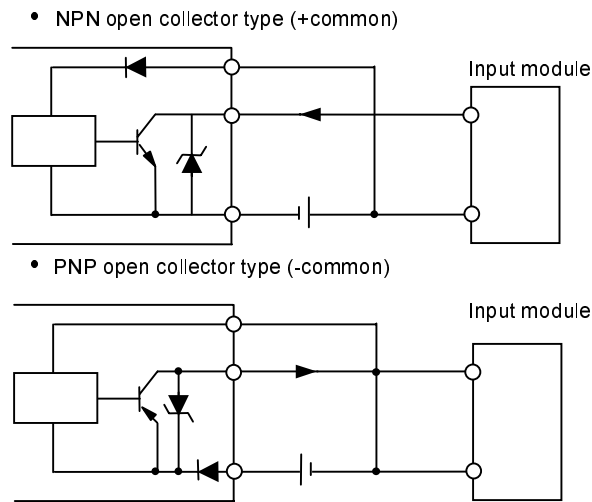

- (4) If a switch with an LED display is used, the current (leakage current) through the LED may cause the erroneous input (always ON). In this case, install a bleeder resistor to lower the input impedance.

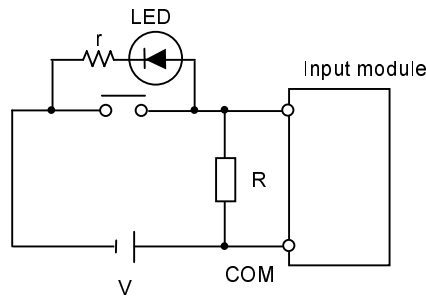

(An example of selecting a bleeder resistor R)

When the voltage between input terminals is V_d at the switch OFF state (with no bleeder resistor), the resistance (R) and the wattage (P) of bleeder resistor can be selected as follows.

In the case of DI633,

$V=24V_{dc}$, Input impedance $Z_i=3.0K\Omega$, OFF voltage $V_o=3.6V_{dc}$

Leakage current $I_L=2mA$,

$$\frac{3.0R[K\Omega]^2}{3.0[K\Omega] + R} \times 2[mA] < \frac{3.6[V]}{R}$$

As a result,

$$R < 4.5[K\Omega] \rightarrow R = 3[K\Omega]$$

$$P = \frac{(24[V])^2}{3000[\Omega]} \times (2.5 - 3) \doteq 0.5[W]$$

Also, when the bleeder resistor is selected in the above manner, the contact current at the switch ON state should be checked.

$$\text{Contact current} = 24[V] \times \frac{3.0[k\Omega] + R}{3.0[k\Omega] \times R} = 16[mA]$$

- (5) If the two-wire proximity switch and other solid-state switches are used, be sure that there is no possibility of mis-inputting because of the leakage current, as in procedure (4). (See (4) for details on how to select a bleeder resistor.)

Also in this case, because of the effect of the saturation voltage (voltage drop) at ON, regardless of whether the switch is ON, the input terminal voltage may not be able to reach the ON voltage, thereby falling to read as input ON.

If input voltage is low or if wiring is too long, special measures are necessary.

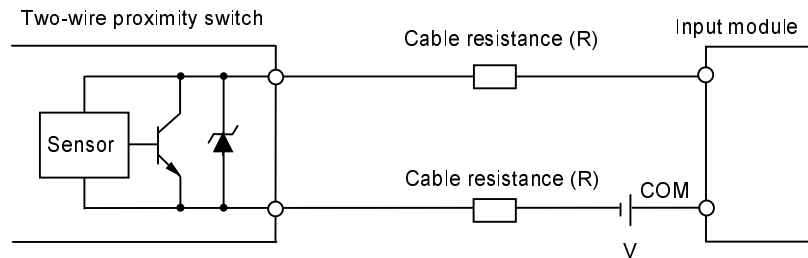

If the cable resistance value is expressed as $R[\Omega]$, $V_d[V]$ for the voltage drop of the proximity switch, and $Z_i[\Omega]$ for the input impedance of the input module, the voltage $V_i[V]$ applied between the input module terminals will be as expressed below (when the proximity switch is ON) :

$$V_i = \frac{V - V_b}{2R + Z_i} \cdot Z_i$$

If the above V_i is lower than the minimum ON voltage of the input module, input voltage V must be raised or the value of the cable resistor R must be made smaller.

- (6) Because the input filter time constant of the high-speed response input module (DI635H) is set to small, the input module may read the wrong input due to chattering of the constant. Use the high-speed response input module to connect with solid-state devices. Also, take measures to suppress noise.
- (7) If input wiring is too long, take measures to prevent erroneous input caused by noise, as follows.
- Wiring length must be minimized. Do not make unnecessary loops.
 - Keep the input wires away, at least 200mm, from power cables and high frequency lines, or shielded the input cables with a metal plate.
 - If possible, use relays at the leading in the control panel.
 - For some cases, use a shielded cable or twisted-pair cable.
 - Install a bleeder resistor to reduce input impedance.

- (8) If dynamic scan input is configured using a DC input module and a DC output module, in addition to the response-delay of output and input, consider the difference of timing caused by the S2T scan. Moreover, diodes must be installed to prevent erroneous input caused by detour circuit. (the figure below is an example of 4×4 input)

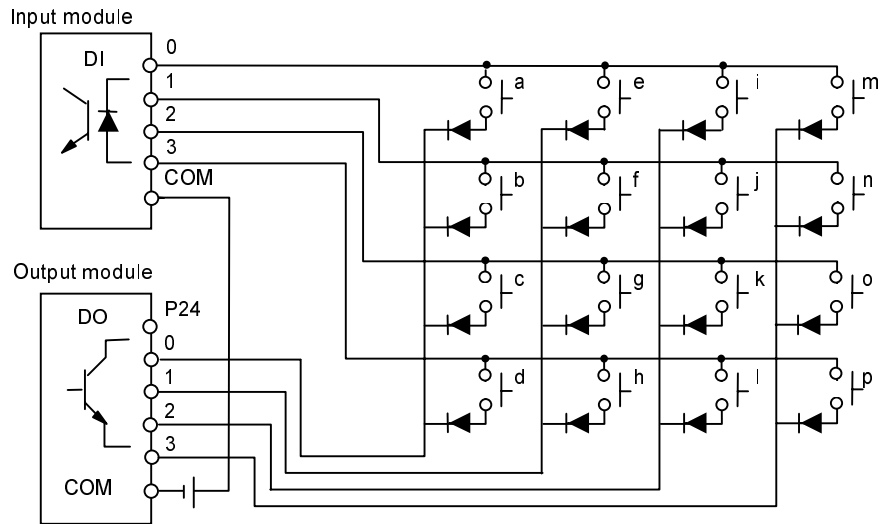

For example, when contact a is ON, the change timing between output 0 and input 0 is as follows.

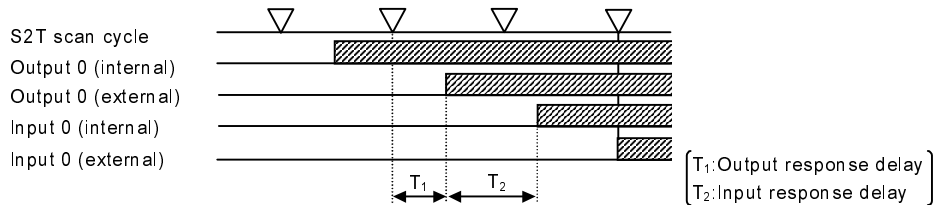

Note that the change timing of output 0 and input 0 will be affected with the scan time of the S2T and the response time of input and output.

3

3.2 Precautions for AC Input Modules

- (1) The conditions to read the ON/OFF state of the input signals are as follows.
 Input ON time \geq ON delay time (OFF \rightarrow ON)+Input reading cycle
 Input OFF time \geq OFF delay time (ON \rightarrow OFFN)+Input reading time
 The "input reading cycle" means the S2T scan cycle for the refresh input, or the execution interval of a direct input instruction when the instruction is used.
- (2) When an AC output sensor is connected to the I/O module, due to the leakage current from the sensor at OFF, there may be a voltage which exceeds the maximum OFF voltage between the input terminals. This will make the S2T unable to read input OFF when the sensor is OFF. In the case, install a bleeder resistor between the input terminals to lower the input impedance.

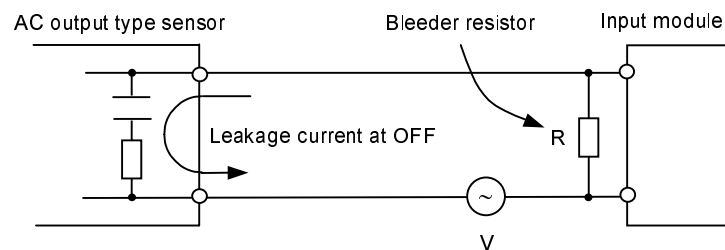

(An example of selecting a bleeder resistor R)

Input module IN635

$$\left[\begin{array}{l} \text{Input impedance: } 10\text{K}\Omega(50\text{Hz}) \\ \text{OFF voltage: } 30\text{Vac} \end{array} \right]$$

Input voltage $V=100\text{Vac}$ (50Hz)

When the voltage between input terminals is V_d at the switch OFF state (with no bleeder resistor), the resistance (R) and the wattage (P) of bleeder resistor can be selected as follows.

$$\frac{10[\text{k}\Omega] \times R}{10[\text{k}\Omega] + R} \times \frac{30[\text{V}]}{10[\text{k}\Omega]} > 25 [\text{V}]$$

As a result,

$$R < 50[\text{k}\Omega] \rightarrow R = 20[\text{k}\Omega]$$

$$P = \frac{(100[\text{V}])^2}{200\phi[\Omega]} \times (2.5 - 3) \approx 1.5[\text{W}]$$

Also, when the bleeder resistor is selected in the above manner, the load current at the sensor ON state should be checked.

$$\text{Sensor output load current} = 100[\text{V}] \times \frac{10[\text{k}\Omega] \times R}{10[\text{k}\Omega] + R} + R15[\text{mA}]$$

- (3) If external lines for AC input become longer with using a multi-core cable, induced current may flow to a open wire from charges wires due to the electrostatic capacity of the cable, causing an erroneous ON input. In this case, install a bleeder resistor between the input terminals to lower the input impedance. Or, you had better apply the DC input.

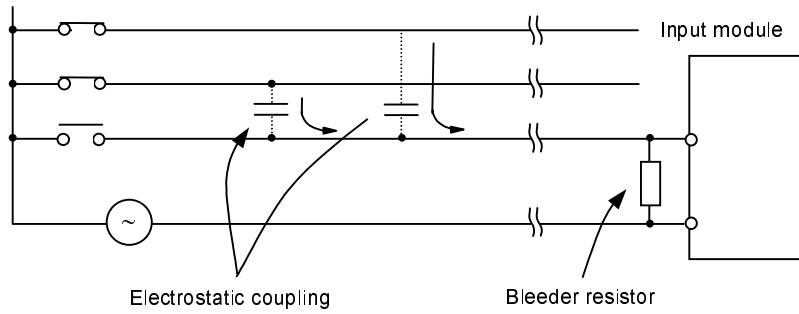

- (4) If the AC lines are installed in parallel with high frequency or power lines, induced current may cause erroneous input. In this case, take necessary countermeasures as follows.
- Change the installation route of AC input lines so that they are not parallel with power lines and high frequency lines.
 - Use twisted-pair cables as input lines.
 - Use shielded cables as input lines.
 - Use relays at the leading in the control panel (the relay must satisfy larger ON current).
 - Install a bleeder resistor to lower the input impedance.
- (5) If the input module and an inductive load are connected in parallel, a surge voltage generated at both-ends of the load when the contact is changed to OFF may cause a malfunction of the S2T. In the case, install a surge absorption element in parallel with the load to suppress the surge voltage.

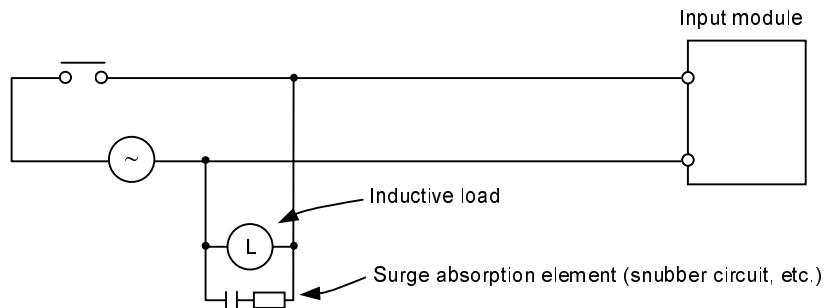

3

3.3 Precautions for DC Output Modules

- (1) The DC output module needs an external power supply to drive output transistors. For each common, connect the load power to the appropriate terminal. (For details, see 2.3 I/O module specifications)
If the wrong polarity of the power supply to the terminal is connected, the module will be damaged. Check the polarity before connection.
- (2) Protection coordination against over-current of DC output module

Type of module	Protection
DO633/DO633P (16-point output)	A fuse of 5A per common(16 points) is built in this DC output module. For an overload and load short-circuit, the transistor will not be protected. This fuse, however, protects the DC output module and the external cable from burn-out.
DO634/DO635 (32/64-point output)	The load short-circuit, etc. will cause burn-out of the module and external cable, because a protection fuse is not built in this DC output module. Therefore, install an appropriate fuse on the outside to prevent accidental burn-out.

- (3) A diode as shown in the figure below is built in to protect the transistor from transient overvoltage.

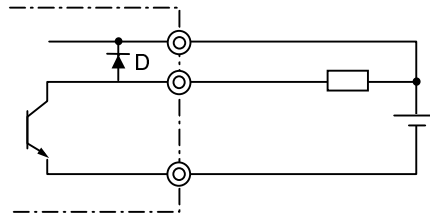

D: Bypasses transient overvoltage to the power supply and suppresses the voltage between the collector and emitter of the transistor.

- (4) Pay attention to the following cases caused by the diode mentioned in (3).

<Case 1>

When connecting to the external equipment in which DC power supply is provided from internal, if the voltage of P1 is higher than one of P2 or if P2 turns to OFF when P1 is ON, the external equipment may turn to ON in spite of the output status.

Because a load current flows through D: a diode.

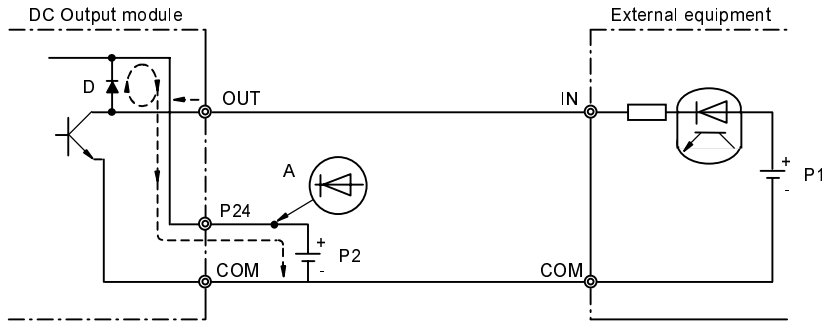

A power supply should be basically used for P1 and P2.
 In the above case, insert a diode for preventing a back current in the position A so that a back current is prevented from flowing into P2.

<Case 2>

When the power cable connected to the P24 terminal is cut off, external load may be driven because the load current of OFF output circuit(OUT0) flows through the diode and the transistor of ON output circuit(OUT1) as shown below.

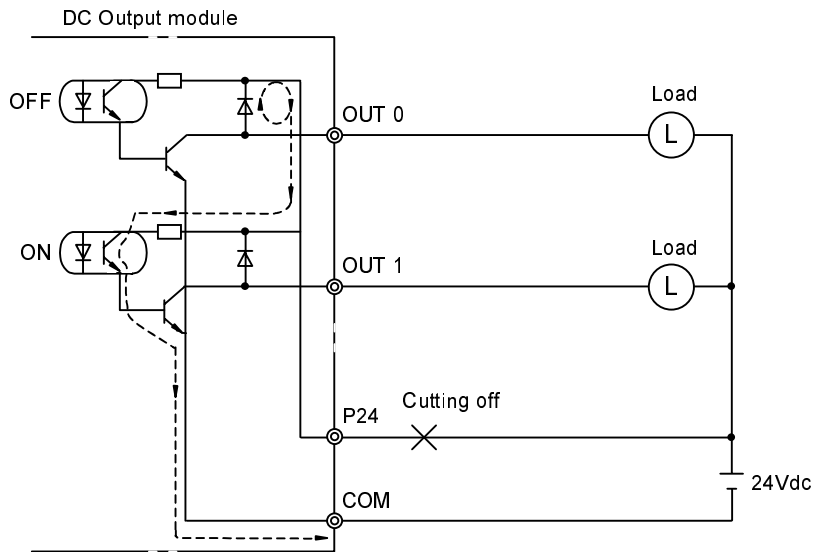

Pay attention for preventing a P24 line from cutting off.

3

- (5) If a capacitive load is connected, rush current will flow when output is charged to ON.
 At that time, necessary measures must be taken to protect the output transistor from being destroyed by the rush current.
 To limit the rush current there are two effective measures. One is to connect a resistor to the load in series. The other is to apply dummy current to the load by connecting a resistor between the output terminals.
- (6) If an inductive load is connected, transient overvoltage will occur when the output is changed to OFF.
 This surge voltage will be absorbed into the diode D mentioned before so that the transistor will be protected. However, if the output cable is installed closely to other signal lines, the surge voltage may cause other problem. In this case, install a flywheel diode in parallel with the inductive load (as near as possible to the load).

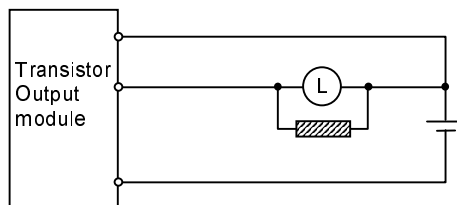

A suitable surge absorption element should be selected according to the application.

- | | | |
|-------------------------------------------------------------------------|--|------------------------------------------------------------------------------------------------------------------|
| ① Flywheel diode
(for voltage clamping) | | Peak inverse voltage:
3 times the power supply
voltage or more
Forward current:
Load current or more |
| ② Varistor
(for voltage clamping) | | Rated voltage about
twice the maximum(peak)
power supply or more |
| ③ Snubber(CR)
voltage circuit
(for high frequency
attenuation) | | R: 0.5 - 1Ω per 1V coil voltage
C: 0.5 - 1μF per 1A coil current
(Non-polar capacitor) |

3.4 Precautions for AC Output Modules

- (1) **Over-Current Protection Coordination**
 One 2A fuse per 4 output points is mounted in the triac output module. Although, taking account of protecting elements by the fuse blowing even in load short circuits, when the fuse blows the semiconductors are subjected to considerable damage. Therefore, take care in handling and wiring so that short circuits will not occur.
- (2) If an inductive load is connected, transient overvoltage will be generated at the output is changed to OFF. To prevent malfunction caused by this surge voltage, a CR snubber circuit is installed in the AC output module. However, to prevent the problem for other signal systems, install a surge absorption element in parallel with the inductive load (install a surge absorption element as near as possible to the inductive load).

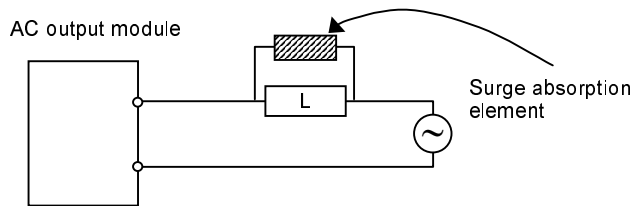

Surge absorption element:

- Varistor (for the voltage clamp)



Bi-directional overvoltage absorption element with a rated voltage of approx. 1.2 times of the max. voltage (peak voltage)

- Snubber (CR) circuit (for high-frequency attenuation)



$R(\Omega)$ = DC resistance value of the load

$$C(\mu F) = \frac{I^2}{10} - \frac{I^2}{20} \quad (I: \text{peak value of load current in ordinary time})$$

- (3) Because the AC output module does not have a zero-cross function, the OFF→ON occurs regardless of the load voltage phases. However, the ON→OFF change occurs when load current is near zero. Check this point in load response.

3.5 Precautions for Relay Output Modules

- (1) The relay output module (RO663, RO662S) needs external 24Vdc power for driving relays. (For details, see 2.3 I/O module specification.)
- (2) Because the relay output module does not have a built-in fuse to protect from overcurrent, install a fuse appropriate to the load current on the external wire. If the protective fuse is not inserted, module patterns could be burn out when a load is shorted.

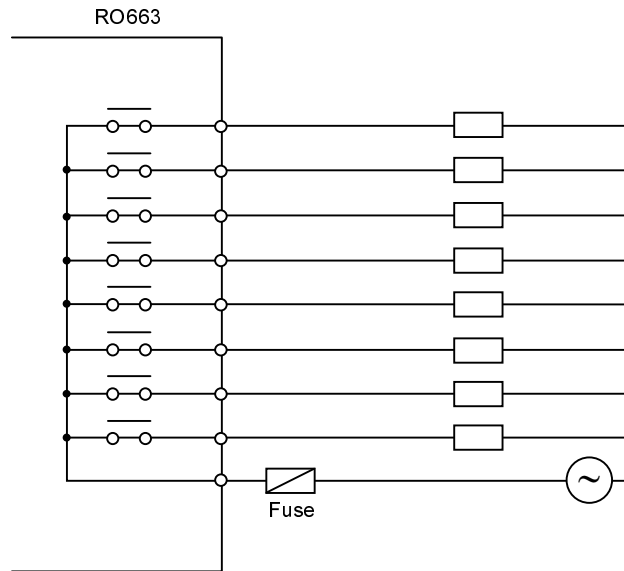

- (3) The relay output module does not have a built-in surge absorption element. To connect an inductive load, always install a surge absorption element in parallel with the load. For details on selecting a surge absorption element, see 3.3 (6) and 3.4 (2).

3.6 Precautions for Analog Input Modules

- (1) Use a shielded twisted-pair cable for the analog input signal line, and wire over the minimum distance. Wire the grounding of the cable shield on the analog input side (the S2T side). ① in the drawing below is the basic. Sometimes, operation is more stable if the wiring is as in ② or ③.

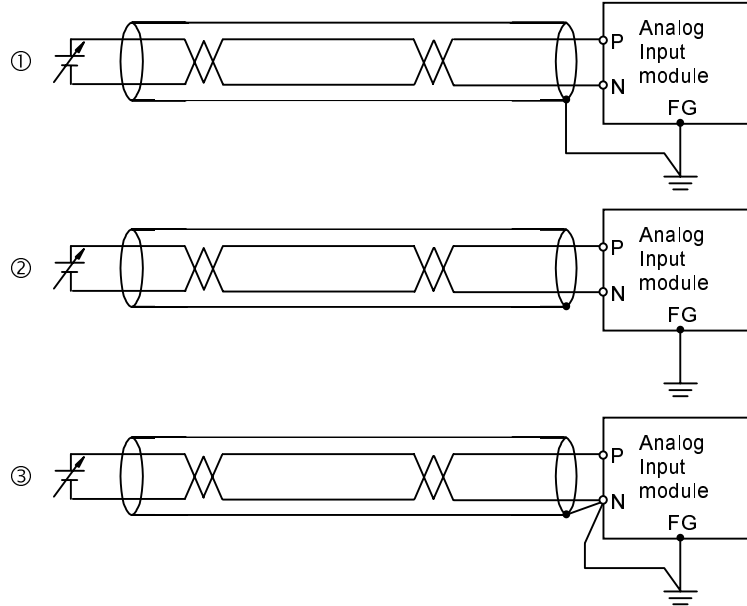

- (2) Sometimes the conversion values are unstable, depending on the voltage state of the external 24Vdc power supply. If the conversion result is not stable, use a dedicated power supply for analog.
- (3) All intrinsically shielded cables are fitted with ferrite choke adjacent to analog inputs/outputs, and must have ground connections to grounded metalwork within 5cm for applying to the EMC Directive.

3

3.7 Precautions for Analog Output Modules

- (1) Use a shielded twisted-pair cable for the analog output signal line, and wire over the minimum distance. Wire the grounding of the cable shield on the load side. ① in the drawing below is the basic. Sometimes, operation is more stable if the wiring is as in ② or ③.

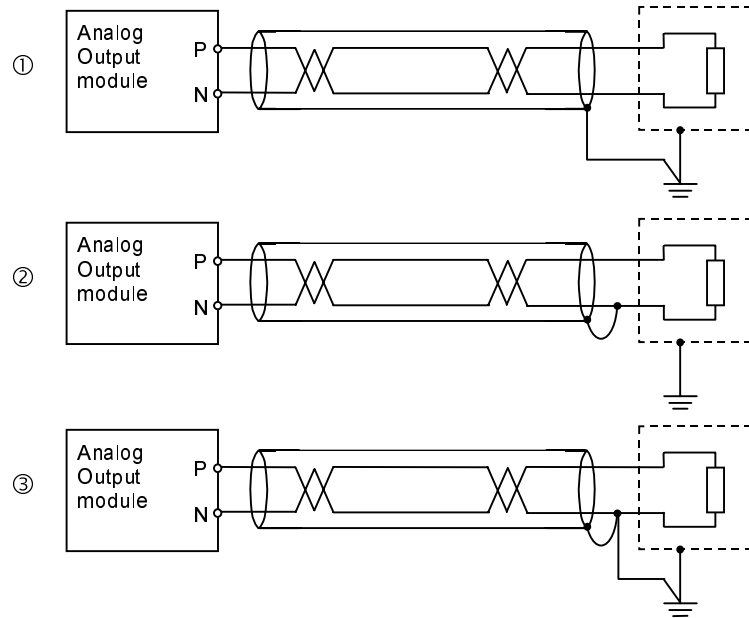

- (2) Sometimes the conversion values are unstable, depending on the voltage state of the external 24Vdc power supply. If the conversion result is not stable, use a dedicated power supply for analog.
- (3) All intrinsically shielded cables are fitted with ferrite choke adjacent to analog inputs/outputs, and must have ground connections to grounded metalwork within 5cm for applying to the EMC Directive.

Chapt.4 Installation and Wiring

4.1 Operating environment

Do not install the S2T in the following locations :

- (1) Where the ambient temperature drops below 0°C (32°F) or exceeds 55°C (131°F)
- (2) Where the relative humidity drops below 5% or exceeds 90%
- (3) Where there is condensation due to sudden temperature changes
- (4) Where there are vibrations that exceed the tolerance of the S2T
- (5) Where there are shocks that exceed the tolerance of the S2T
- (6) Where there are corrosive or inflammable gasses (The installation location should be below 0.05ppm of sulfurous acid gas, below 0.01ppm of hydrogen sulfide.)
- (7) Where there are dust, machining debris or other particles
- (8) In locations exposed to direct sunlight

Observe the following precautions when installing enclosures for mounting the S2T :

- (1) Provide the maximum possible distance between high-voltage or high-power panels. This distance must be at least 200mm (8IN).
- (2) If the enclosures are installed near high-frequency equipment, be sure to ground the enclosures correctly.
- (3) When sharing the channel base with other panels, check for leakage currents from the other panels or equipment.

CAUTION

1. Excess temperature, humidity, vibration, shocks, or dusty and corrosive gas environment can cause electrical shock, fire or malfunction. Install and use the S2T and related equipment in the environment described in this manual.
2. Improper installation directions or insufficient installation can cause fire or the units to drop. Install the S2T and related equipment in accordance with the instructions described in this manual.

4.2 Installing bases

Installation precautions :

- (1) Because the S2T is not of dust-proof construction, install it in a dust-proof control panel.
- (2) Do not install the bases directly above equipment which generates a large amount of heat, such as a heater, transformer, or large capacity resistor.
- (3) Do not install the bases within 200mm (8in) of a high-voltage or power cable.
- (4) Allow at least 70mm on all sides of the base for ventilation.
- (5) For safety during operation and maintenance, install the base as far as is possible from high-voltage or power equipment.
Alternatively, isolate the base using a steel plate or similar separator.
- (6) Decide the bases mounting position with considering the length of the expansion cables.
- (7) Install the bases in fully contacting with the mounting frame in order to equalize the potentials of basic and expansion bases.
- (8) In the vicinity of high-voltage and power equipment, it is necessary to give consideration to grounding. (See 4.5 Grounding)
- (9) Install the bases where the power modules are always mounted on the left hand side, vertically on the mounting frame.
- (10) Mount the bases securely, using the base mounting screws of M4 size.
(Screws torque : approx. 1.47N•m=15kgf•m)

The installation dimensions is as follows.

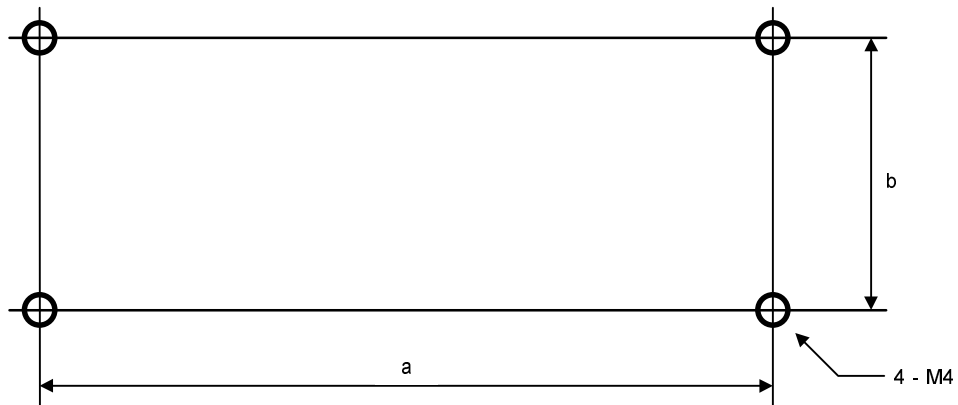

Type	a [mm]	b [mm]	Weight [g]	Remarks
BU648E	402.5	95	900	
BU668	402.5	95	900	
BU666		95	850	Under development
BU664		95	800	

4.3 Mounting the Modules

There are three types of module, 1-slot width module such as the S2T CPU and direct I/Os, 2-slot width module and narrow width module such as the expansion interface. Basically each module is similar structure and similar handling except some special modules.

The modules are fixed to the base with both upper/lower lock levers and mounting screws.

Turn power OFF before installing and removing modules.

4.3.1 Basic procedure for mounting/removing the modules

■ Procedure for mounting

(1) Turn off power of the S2T and external power supplied to I/O modules.

(2) Install the bases on the panel.
(Refer to Section 4.2)

(3) Check the mounting position of the modules.

Expansion interface	:at the extreme left of the base
Power supply module	:at the right of the expansion interface
Station modules	:between the power supply module and I/O modules (in the slots that have two connectors)
S2T CPU	:at the right of the power supply module
I/O modules	:at the left of the station modules (on main base) or the power supply module (on expansion base)
Space modules	:in the slots that have no modules
Unit cover	:at the extreme left of the base using as a basic unit without expansion

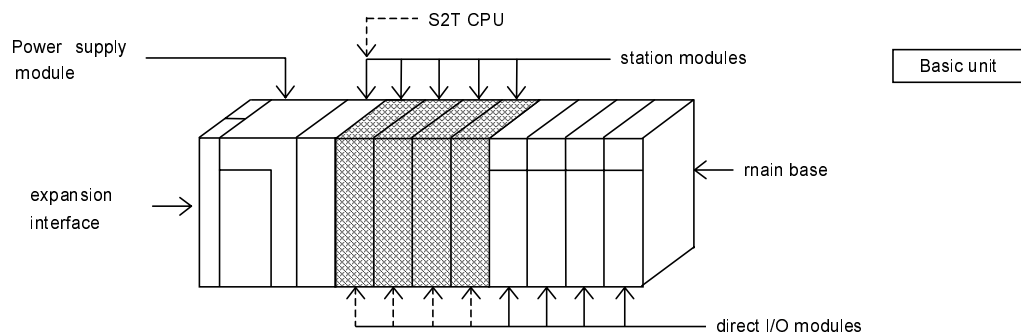

- (4) Put the module along the top / bottom leads of base.

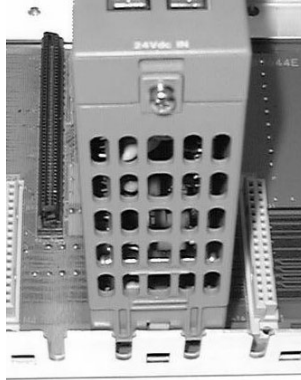

- (5) Push the module slowly and vertically, supporting the top/bottom by hands until it clicks into the base.

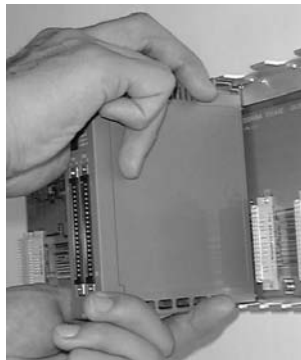

- (6) Mount the module securely, using the attached module mounting screw of M4 size. (Screws torque: approx. 1.47N•m=15kgf•cm)



- (7) Remove the cover of modules or open the cover of terminal blocks. Refer to Section 4.3.2 for details.
- (8) Wire and connect cables with terminal blocks or connectors. Use crimp-style terminals with sheaths.
- (9) Check the wiring and confirm if the terminal blocks are secured. Then mount the cover of modules and close the cover of terminal blocks.

4

■ Procedure for removing

- (1) Turn off power of the S2T and external power supplied to I/O modules.
- (2) Remove the cover of modules.
- (3) Disconnect the cables from the modules.
 - Expansion interface :Disconnect the expansion cables
 - Power supply module :Disconnect the cables from terminal blocks
 - Station module :Disconnect the communication cable, etc.
 - S2T CPU without station bus
 - I/O modules :Disconnect the cables from terminal blocks or the removal terminal blocks or the connectors

- (4) Loosen the screw at the top of module.



- (5) Push the upper lock lever of module by one hand, and press the lower mark of module by another hand.



4

- (6) Remove the module vertically against the base.

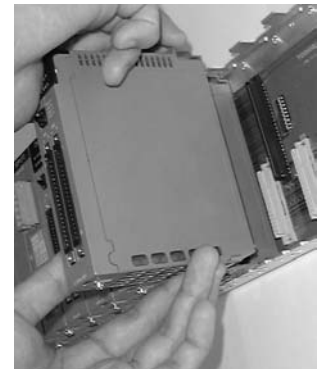

NOTE

- (1) After installing the modules, secure the bases so that it can be mounted vertically, including when in transport.

 **CAUTION**

1. Install the S2T modules - power supply, CPU, direct I/Os on the dedicated base.
Do not use any modules of the S2T for the purpose other than specified. This can cause electrical shock or injury.
2. For safety, always turn power OFF before installing and removing modules or installing and removing terminal blocks.
3. Entering wire scraps or other foreign debris into to the S2T and related equipment can cause fire or malfunction. Pay attention to prevent entering them into S2T and relatde equipment during installation and wiring.
4. Check for proper connections on wires, connectors and modules. Insufficient contact can cause malfunction or damage to the S2T and related equipment.

4.3.2 Installing/removing of the module cover

■ Expansion interface

- (1) Push the mark on the top of module cover.



- (2) Remove the cover, hanging the bottom as supporting point.



* Hang the bottom hook of the cover at first and lock the top when installing.

■ Power supply module

- (1) Push the mark on the bottom of module cover.



- (2) Remove the cover, hanging the top as supporting point.



* Hang the top hook of the cover at first and lock the bottom when installing.

4.4 Connecting expansion units

Up to three expansion units can be connected to the S2T basic unit.

The expansion interface modules are mounted in both the basic unit and the expansion units and connect each other with expansion cables.

This procedure is shown as follows.

- (1) Turn off the power of the S2T.
- (2) Mount the expansion interface modules on the bases.
- (3) Remove the cover and set the unit address, then connect the expansion cables between the bases.
- (4) Connect the cables as below.
The upper side connector is for input from previous unit and the lower side connector is for output to the next unit.
- (5) Install the cover.

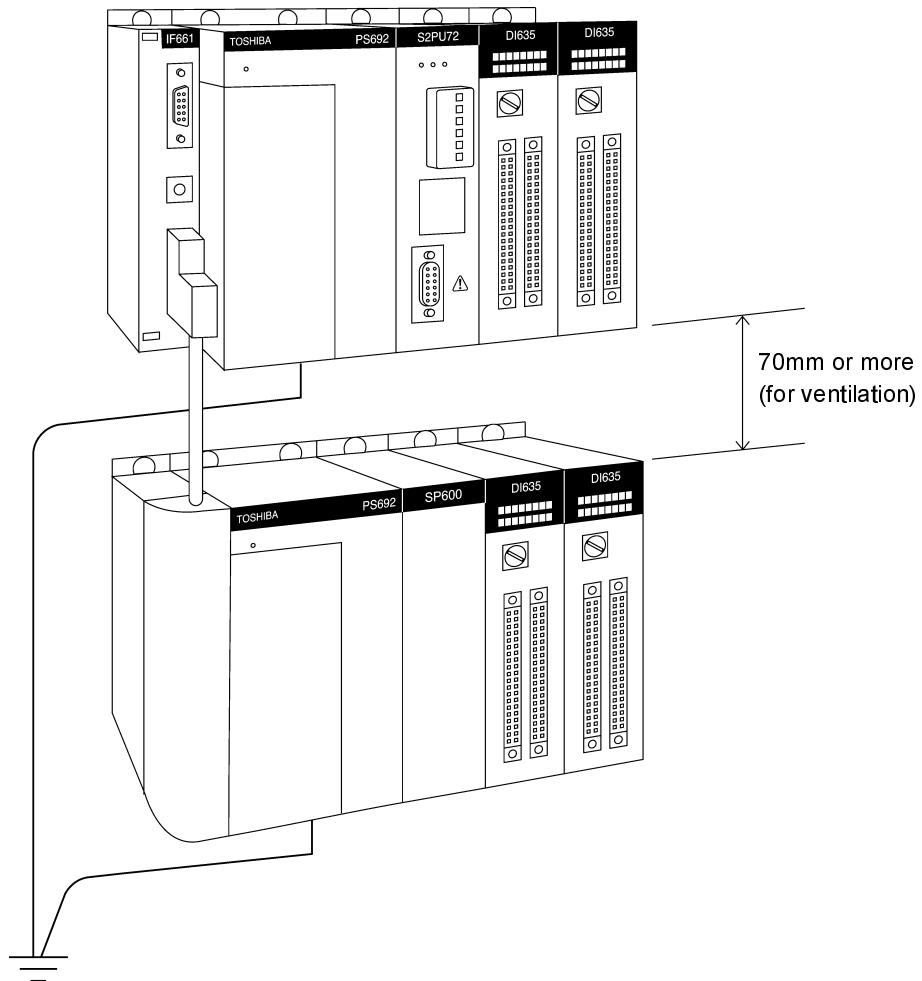

NOTE

- (1) Separate the expansion cables as far as possible from other cables. In particular, separate them at least 200mm from power lines.
- (2) Four types of expansion cables are available - 0.3m, 0.5m, 0.7m and 1.2m. Select according to the positions of the units.

4.5 Grounding

It is advisable, for the grounding of electronic devices to carry out dedicated grounding which is isolated from that of power systems, and to carry out single-point grounding between 2 or more electronic devices. The S2T is designed to apply to EMC which takes the actual application into account, and it has a satisfactory noise-immunity without carrying out grounding of the device itself. However, as a precaution, correct grounding is recommended from the viewpoint of reliability.

 CAUTION
Operation without grounding may cause electrical shock or malfunction. Connect the ground terminal on the S2T to the system ground.

4.5.1 Check points for grounding

Check the grounding against the following criteria :

- (1) The S2T must not become a path for a ground current. High-frequency currents are particularly harmful.
- (2) Equalize the ground potentials when 2 or more units of electronic equipment are to be connected. Ground them at single-point.
- (3) Do not connect the ground of the S2T to that of high-power system.
- (4) Do not use a ground that has unstable impedance, such as painted screws, or grounds subject to vibration.

4.5.2 Grounding methods

(1) Grounding of control panel

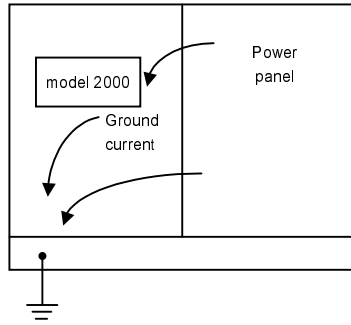

↓ change

↙ change

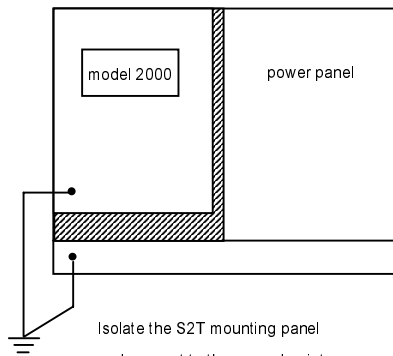

Isolate the S2T mounting panel and connect to the ground point separately.

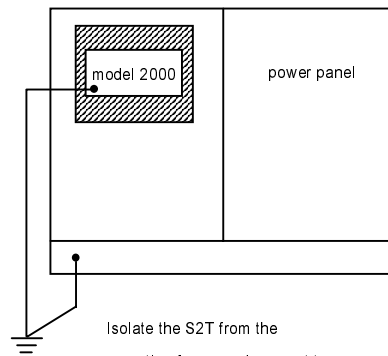

Isolate the S2T from the mounting frame and connect to the ground point separately.

(2) Grounding between units

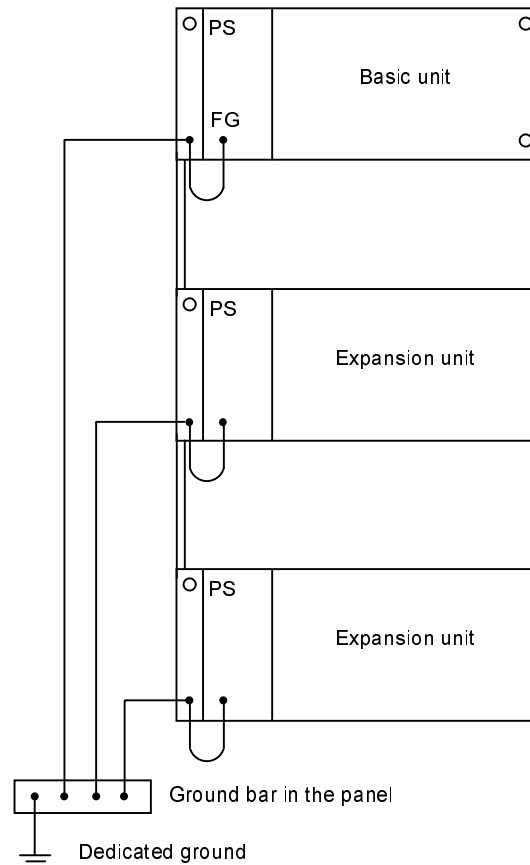

- Connect the FG terminal of the power supply module to the unit mounting screw, and to the ground bar in the panel by 2mm² or larger wire in shortest possible distance.
 - Use a dedicated ground for the control circuit, and keep the ground cable away from that for high-power systems.
 - 100Ω or less to earth is recommended.
- (3) Line Filter ground (LG) terminal
 The LG terminal is a neutral point of the primary power supply line filter. It can suppress the effect caused by the noise from power supply line, by grounding the LG terminal.
 Therefore, normally, ground the LG terminal together with the FG terminal.
 However, depending on the power system, leakage current to the ground from the LG may cause problems. In this case, install an isolated transformer in the power line, or open the LG terminal. If the unit is installed in isolation, open the LG terminal.
 Do not connect the LG and FG terminals without grounding them.
- (4) Frame ground (FG) terminal
 The FG terminal is a protective ground point of the S2T. The FG terminal voltage is equalized to that of the base. For safety, ground them at single-point in order to minimize the risk of electrical shock.

4.6 Wiring of the power supply

Wire the external power supply to the S2T power supply module in the following manner.

When using expansion units, arrange for power to be supplied simultaneously to the basic unit and the expansion units (or to the expansion units before the basic unit).

- (1) Power conditions

Rated voltage	:85 to 264Vac, 50/60Hz(PS692)
Power consumption	:50VA or less (PS692)
Retentive power interruption	:10ms or less

- (2) Install an electrostatic shielded transformer or a noise filter if the power contains noise. See the figure at the bottom.
- (3) Use twisted-pair cables (1.25mm²) as the power supply cable. Keep the cable as far as possible from I/O cables.
- (4) If the expansion unit with a power supply module is used, the power of the basic and expansion units should be supplied from the same source. Apply power at the same time or in the order of the expansion unit then the basic unit.
- (5) If a CVCF or UPS supplies power to the S2T, observe waveforms of the power supply; the peak voltage must be more than 130V for the 100Vac range or 260Vac for the 200Vac range.

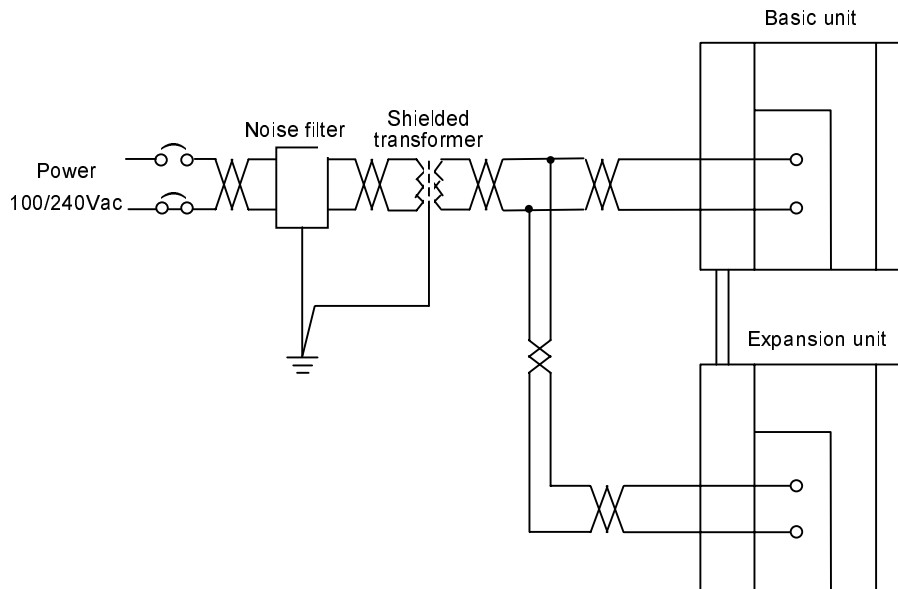

■ Wiring of the power supply module

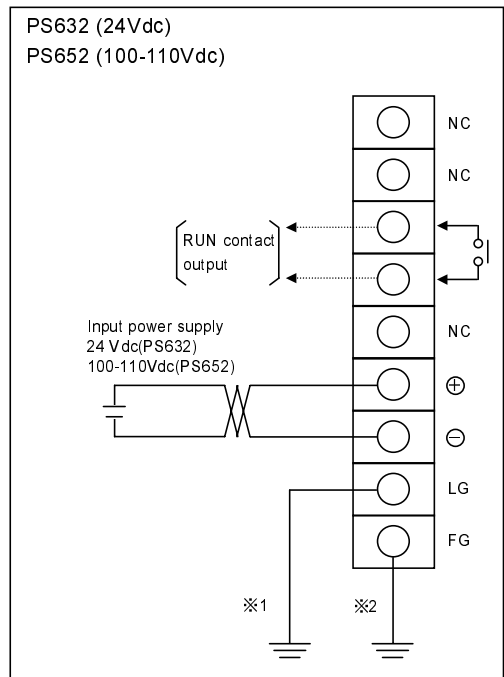
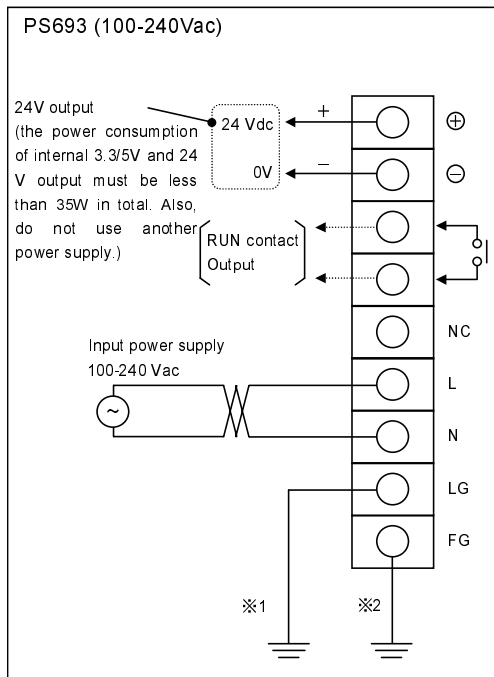
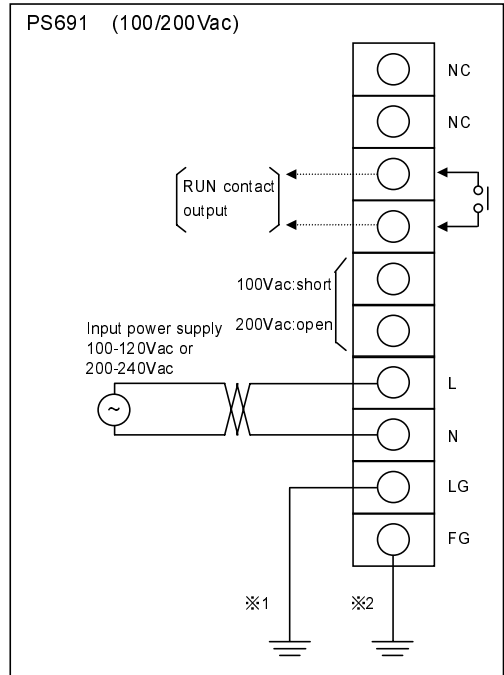
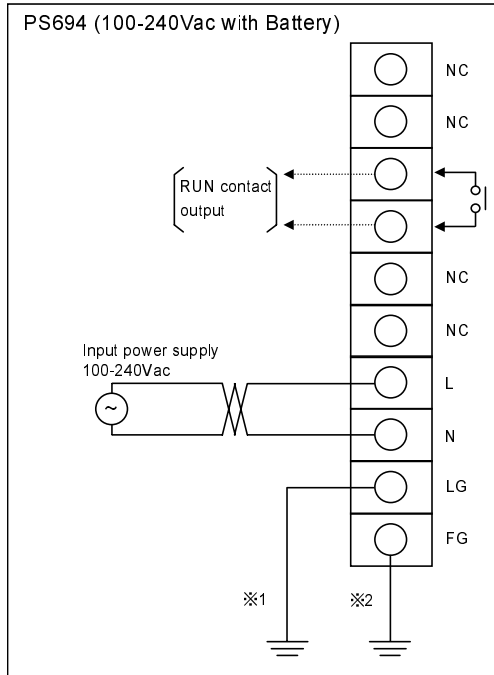

4

※1 Line Filter Ground Terminal (LG)

Connected to the power supply lines via capacitors. Grounding terminal.

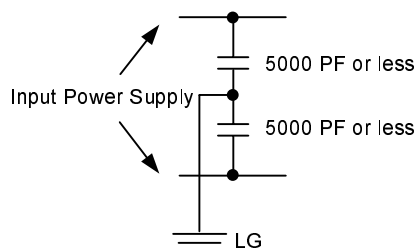

Usually the LG and FG terminals are shorted before grounding.. However, the LG terminal may be open or used for dedicated grounding, depending on the environmental condition (such as leak current or when the power supply system is grounded elsewhere)

※2 Frame Ground Terminal (FG)

Connected to the unit base frame. Grounding terminal.

 **CAUTION**

1. Turn off power before wiring to minimize the risk of electrical shock.
2. Exposed conductive parts of wire can cause electrical shock. Use crimp-style terminals with insulating sheath or insulating tape to cover the conductive parts. Also close the terminal covers securely on the terminal blocks when wiring has been completed.
3. Operation without grounding may cause electrical shock or malfunction, Connect the ground terminal on the S2T to the system ground.
4. Applying excess power voltage to the S2T can cause explosion or fire. Apply power of the specified ratings described in the manual.
5. Improper wiring can cause fire, electrical shock or malfunction. Observe local regulations on wiring and grounding.
6. Do not connect any cables to the NC terminals.

NOTE

The size of the terminal screw is M3.5. Use an appropriate crimp-style terminal with a width of 7mm (0.27in) or less for the M3.5 screw.
C2(C2PU35) needs Windows shutdown, so C2 is used in system, recommended Power Supply Module of Base unit is PS694. PS694 has battery, system allow power failure, Windows shutdown automatically. PS691 has shutdown sequence interface to UPS, others don't have C2 support functin.

4.7 I/O wiring

Pay attention to the following points when mounting and wiring the I/O modules.

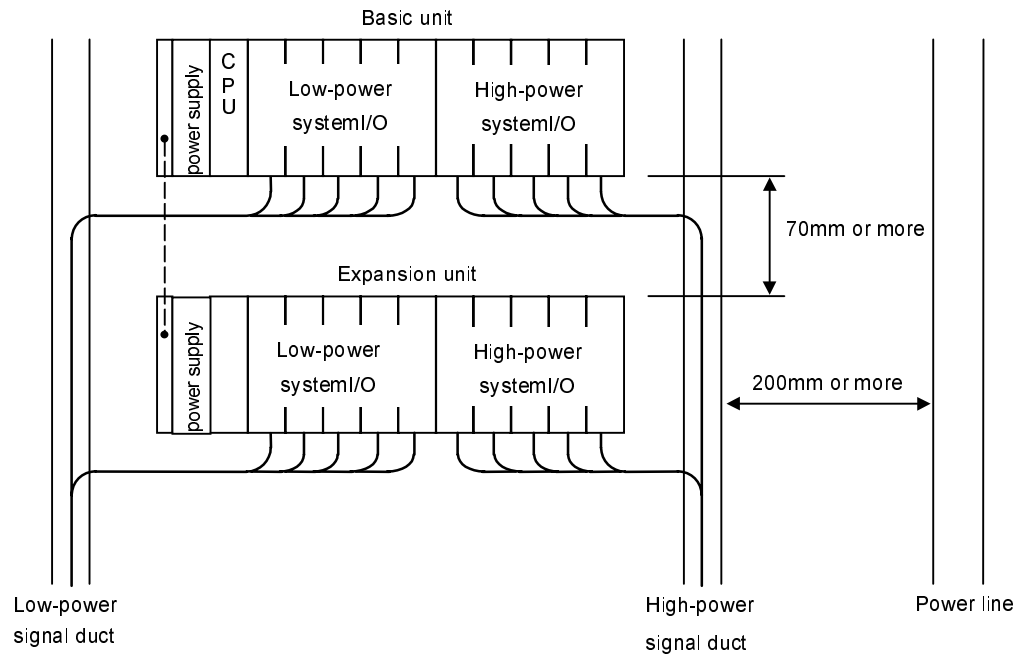

Low-power system I/O
DC input module
Analog input module
Analog output module
Pulse input module
Positioning control module
Serial Interface
Transmission module

High-power system I/O
AC input module
DC output module
AC output module
Relay output module

4

- (1) To improve the unit's resistance to signal interference, install modules for low-voltage signals toward the left of the unit, and modules for power signals toward the right. Also, separate the wires of each.
- (2) Allow at least 70mm clearance between the units and between other control equipment to allow access for maintenance and ventilation.
- (3) When installing the unit near high-voltage or high-power equipment, leave at least 200mm clearance, or shield the unit with a steel plate.
- (4) Refer to the following table for the size of I/O cables.

Type of module	Cable size
16-point module	0.5~1.25mm ²
32/64-point module	0.1~0.3mm ²

However, for common lines, use a thicker size which takes account of the current capacity. Also, for cables outside the panel, the use of cable of at least 1.25mm² is recommended to keep the impedance low.

- (5) The M3.5 screw is used as a terminal screw. Use an appropriate crimp-type terminal with a width of 7mm (0.28 in) or less for the M3.5 screw.
- (6) Do not blind the I/O signal cables and high-voltage or power cables. Separate them as far as possible. If separation is difficult, use shielded cables for the I/O signals and ground the shield at the leading -in point of the control panel.
- (7) Pat attention to Section 3.I/O Precautions for I/O modules.

 **CAUTION**

1. Turn off power before wiring to minimize the risk of electrical shock.
2. Use crimp-style terminals with sheaths as far as possible for wiring to the power supply module. When it is not possible to use crimp-style terminals with sheaths, cover with insulating tape so that the conductive parts are not exposed.
3. Apply power of the specified rating.
Applying excess power voltage to the S2T can cause explosion or fire.
4. Operation without grounding may cause electrical shock or malfunction. Connect the ground terminal on the S2T to the system ground.

4.8 Wiring of the computer link

Cable connection examples show as below.

- Below figure shows an example of cable connection using the RS-232C/RS-485 converter (ADP-6237B).
- Use shielded twisted-pair cable for data communication suited to RS-485 standard. The cable shield should be connected to single-point ground.

One to one configuration

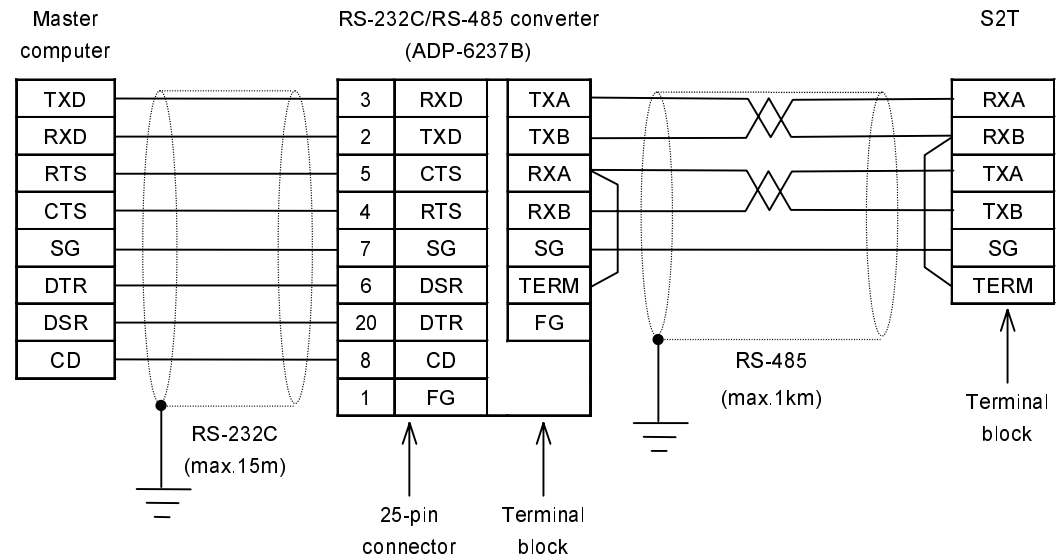

- On the S2T, removable terminal block is provided for cable connection.
- Short between RXA and TERM for termination at both the S2T and the ADP-6237B.
- If the master has RS-485 (or RS-422) interface and the S2T is connected to the master directly, connect termination resistor 1/2 W - 120 Ω between RXA and RXB at the master end.

One to N configuration

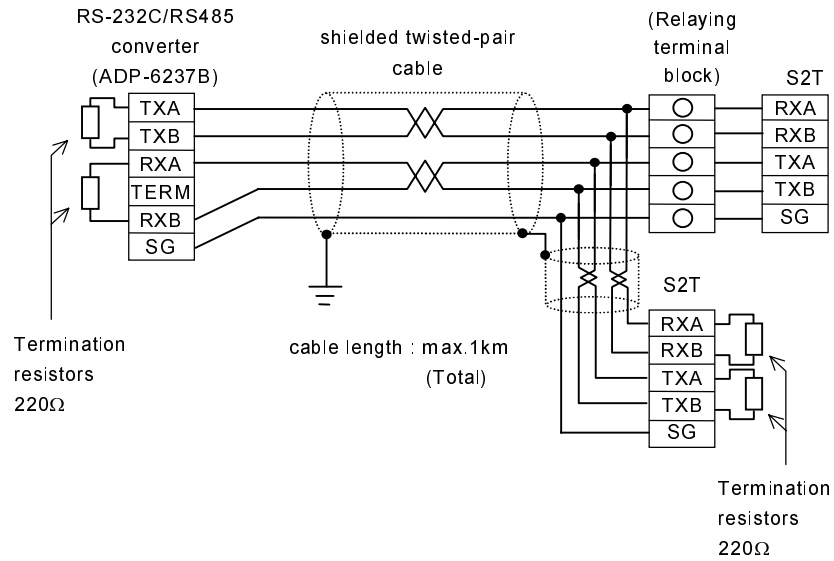

- On the S2T, removable terminal block is provided for cable connection.
- Connect termination resistor 1/2 Ω - 220 W between RXA and RXB, and between TXA and TXB at the both terminal stations.
- Use shielded twisted-pair cable for data communication suited to RS-485 standard. The cable shield should be connected to single-point ground.

4.9 Power up/down sequence

Turn on power or turn off power of the S2T according to the following sequence so that the S2T is used safely and securely.

(Power up sequence)

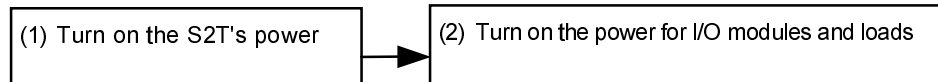

- (1) Turn on power of the S2T at first. When using expansion units, arrange for power to be supplied simultaneously to the basic unit and the expansion units. Use the same power lines for them.
If it is difficult, turn on power of the expansion units before turning on that of the basic unit.
- (2) Turn on power for I/O modules and loads simultaneously.
Use the same power lines for them.
If it is difficult, turn on the external power for I/O modules before turning on the power for the loads.

(Power down sequence)

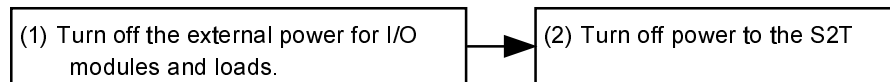

- (1) Turn off the external power for I/O modules and loads simultaneously.
Or turn off power for loads and turn off power for I/O modules in turn.
- (2) Turn off power of the S2T.
When using expansion units, turn off power of the basic unit and the expansion units simultaneously.
Or turn off power of the expansion units after turning off power of the basic unit.

CAUTION

1. Configure the external circuit so that the external power required for output modules and power to the loads are switched off simultaneously.
Also, turn off to the loads before turning off power to the S2T.

4.10 Safety circuit

Configure emergency stop and safety interlocking circuits out of the S2T against faulty of the S2T or breaking wires.

- (1) Emergency stop circuit
- (2) Safety interlocking circuit (forward and reverse etc.)

WARNING

Configure emergency stop and safety interlocking circuits outside the S2T. Otherwise, malfunction of the S2T can cause injury or serious accidents.

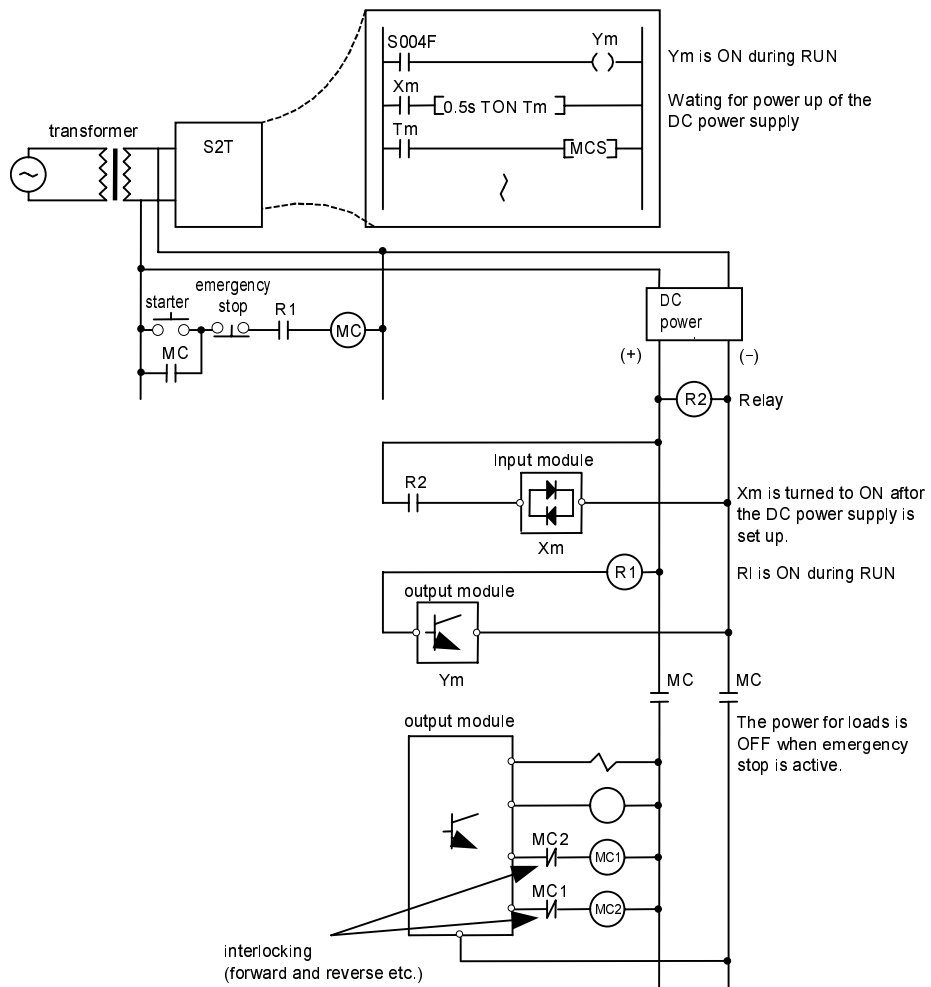

4

Chapt.5 Maintenance and Checking

5.1 Daily checking items

To maintain the system and to prevent troubles, check the following points on daily basis.

Item	Content of checking	Corrective measures
LEDs on the power supply and S2T CPU modules	POWER(green):Lit when 5V power normal	If the LEDs are abnormal, see Section 6, Troubleshooting.
	RUN(green) :Lit when operating normally	
	FLT (red) :Not lit when the CPU normal	
	BAT(green) :Lit when the battery voltage normal	
Input LEDs (digital input)	Lit when the corresponding input signal is ON.	<ul style="list-style-type: none"> • Check that the input voltage is within the specified range. • Check that the input terminal block is not loose. • Check that the modules are installed securely.
Output LEDs (digital output)	Lit when the output is ON and the corresponding external load should operate.	<ul style="list-style-type: none"> • Check that the external load voltage is within the specified range. • Check the built-in fuses. • Check that the output terminal block is not loose. • Check that the modules are installed securely.
Switches on the CPU module	Operation is executed when the operation mode switch (HALT/RUN) is to RUN.	<ul style="list-style-type: none"> • Change the switch to the correct position.

CAUTION

1. Perform daily checks, periodical checks and cleaning to maintain the system in normal condition and to prevent unnecessary troubles.
2. Turn off power immediately if the S2T or related equipment is emitting smoke or odor. Operation under such situation can cause fire or electrical shock. Also unauthorized repairing will cause fire or serious accidents. Do not attempt to repair. Contact Toshiba for repairing.

5.2 Periodical checking items

Check the S2T based on the following points every six months. Also perform checks when the operating environment is changed.

Item	Content of checking	Criteria
Power supply	Measure the voltage of the power (at the terminal of the module)	85 to 264Vac
	Check that the terminal screw of the module is not loose.	Check that the terminal screw of the module is not loose.
	Check that wiring cable is not damaged.	Check that wiring cable is not damaged.
Installation condition	Check that the basic unit is installed securely.	Not loose, no play
	Check that the expansion unit is installed securely.	Not loose, no play
	Check that each module is installed securely.	Not loose, no play
	Check that each expansion cable connector is not loose; and the cable is not damaged.	Not loose, no damaged
Programming	Check that the functions of the programming tool are normal.	Try executing simple operations.
	Check that the connector and the cable are not damaged.	Not damaged
I/O modules	Measure the voltage of each of the I/O modules at the terminal block.	The voltage must be within the specified range.
	Check the LED of the input status display.	The LED must light normally.
	Check the LED of the output status display.	The LED must light normally.
	Check that the I/O terminal block is installed securely.	Not loose, no play
	Check that the terminal screw is not loose and the terminal has a sufficient distance to the next terminal.	Not loose, and not contacting the next terminal
	Check that the wiring cable is not damaged.	Not damaged
Environment	Check that the temperature, humidity, vibration, dust, etc. are within the specified range.	Must be within the general specification range.
Program	Check that the content of the S2T program and the master program (e.g., saved on a HDD disk) are the same.	Check that these programs are identical by comparison.
Battery	Check whether the battery must be replaced. (The installed date is written on the CPU battery cover.)	Replace the current battery if more than two years has elapsed.
	Check that the connector of the battery is inserted firmly.	Not loose

5

 CAUTION
<ol style="list-style-type: none"> 1. Turn off power before checking voltage on terminals. Failure to do so can cause electrical shock. 2. Do not modify the S2T in hardware nor software. This can cause fire, electrical shock or injury.

5.3 Maintenance parts

To recover from failure quickly, it is recommended to keep the following spare parts:

Part	Quantity	Remarks
I/O modules	One of each type used	For the relay contact output, the contact life must be taken into account. See Section 2.3.
Fuses	Number to be used	See Section 5.5.
Battery modules	1	For emergency use. See Section 5.4. (GBT611*AS)
CPU modules	1	Keep a minimum of 1 each to reduce down-time to the minimum.
Power supply modules	1	
Programming tool	1set	Useful for detecting the cause of a failure.
Master program	As required	Keep on MO or the like.

CAUTION

Do not touch activated terminals of I/O modules and bases. Keep the terminal covers closed during power ON.
This can cause electrical shock or injury.

NOTE

Store batteries in a cool (25°C or less) place as self-descharge is greater at high temperatures.

5.4 Battery Replacement

In the RAM mode operation, the program, DW registers and calendar data are kept in the RAM backed-up by the battery module (GBT611*AS).

In the ROM mode operation, the program and DW registers are kept in the built-in Flash ROM and the calendar data are kept in the RAM.

A lithium battery is used, which has little self-discharge and can be used over a wide temperature range. Therefore, during its period of use, and in particular when the non-conducting time is long, it can be used with assurance.

The date of installation of the battery is recorded on the battery cover of CPU.

Under normal use, it is recommended that the battery should be replaced every 2 years. Check the date of installation and replace using the following procedure.

There is an LED(BAT) which indicates normal battery voltage on the front of the CPU module. This is lit when normal. When this LED flashes or is out, the battery comes into life. Therefore replace the battery within 7days. (It is recommended that the power supply should not be switched OFF until actual replacement, in order to protect the program.)

- (1) Insert a flat driver in the ▽ part to press upwards the battery cover for removal.



- (2) Hold the tag of the battery module and pull it towards yourself.



- (3) Hold the tag of a new battery module.

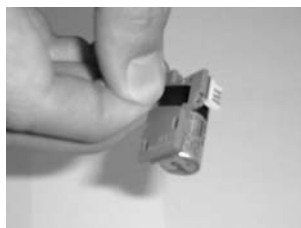

- (4) Insert the battery module in the battery pocket along the guide.



- (5) Write the installed date on the sheet.

- (6) Hook the part on the right end of the battery cover on the module and hold the left end to mount the cover.



Disposal of the battery

Dispose of the battery in the same way as general-purpose dry batteries. There is a risk of explosion if dismantled or burnt.

If the + and - of a lithium battery are allowed to short, this may lead to igniting and fumes.

Don not cut the lead wires and do not dismantle the connectors.

WARNING

CAUTION



Forbidden

Be careful not to accidentally connect the opposite electrode of the battery or charge the battery. Also never try to dismantle, heat, or throw the battery into fire, or make it short-circuited. These actions can cause fire or explosion.



Mandatory

Replace the battery every two years. An exhausted battery can cause the PC to loose data or programs, or the malfunctioning PC can cause mechanical damage or an accident.

NOTE

1. The battery should be replaced with power OFF. The time with battery removed should be within 30 minutes. If the battery is kept removed for a long time, the contents of the RAM memory will be erased, so please take care.
2. When connector of the battery is disconnected, an LED (BAT) is out. Any error message about the battery can't be registered in the error information in this case.
3. When handling the battery, take care of the following points.
 - *The voltage is not compatible with manganese dry batteries and alkali batteries. Do not use these as substitutes.
 - *Never let the + and - of the battery be shorted.
 - *Never dismantle batteries, overteat them or put them into a fire.
 - *Never try to charge a battery. This is not possidle.
4. Do not use a battery which has been stocked more than 3 years since manufactured date.
5. The battery is a dedicated product. Order it from Toshiba. (Product Code:GBT611*AS)

5.5 Fuse Replacement

The following modules have built-in protection fuses.

Type of module	Fuse type	Number of units	Fuse rating
DC output(DO633,DO633P)	EX10*SFA50	1	250Vac-5A
AC output(AC663)	EX10*SFC20	3	250Vac-2A

The AC and DC power supply modules have a built-in protective fuse to prevent burn-out of internal circuits of the modules.

Over long term use, ON/OFF changes of the power may cause fatigue; check the fuse periodically.

The above output modules have protective fuses to prevent their internal circuits from burn-out when short-circuit occur.

Chapt.6 Troubleshooting

6.1 Troubleshooting procedure

If a trouble occurs, determine whether the cause lies on the mechanical side or on the control system (S2T) side. A problem may cause a secondary problem, therefore, try to determine the cause of the trouble by considering the whole system.

If the problem is found in the S2T or in the S2T's I/O operation, check the following points :

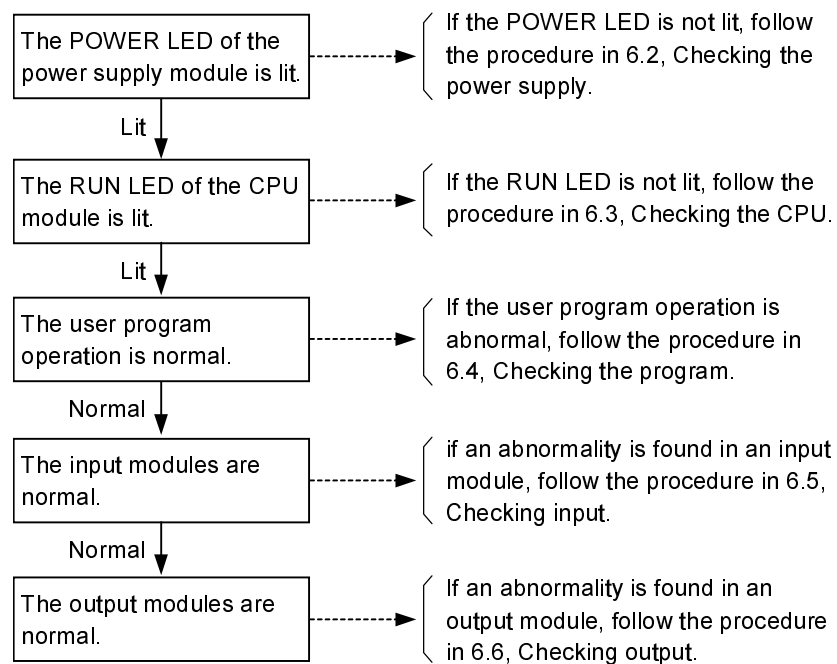

If the problem appears temporary and is synchronous with the operation of the system/equipment, the external environment (noise, voltage fluctuations, etc.) may have caused it. For details, follow Section 6.7.

 **CAUTION**

1. Turn off power before installing or removing any units, modules, racks or terminal blocks. Failure to do so can cause electrical shock or damage to the S2T and related equipment.
2. Check by referring "Troubleshooting" section of this manual when operating improperly. Contact Toshiba for repairing if the S2T or related equipment is failed. Toshiba will not guarantee proper operation nor safety for unauthorized repairing.

6.2 Checking the power supply

If the POWER LED in the front of the power supply module does not light after power ON, check the following points :

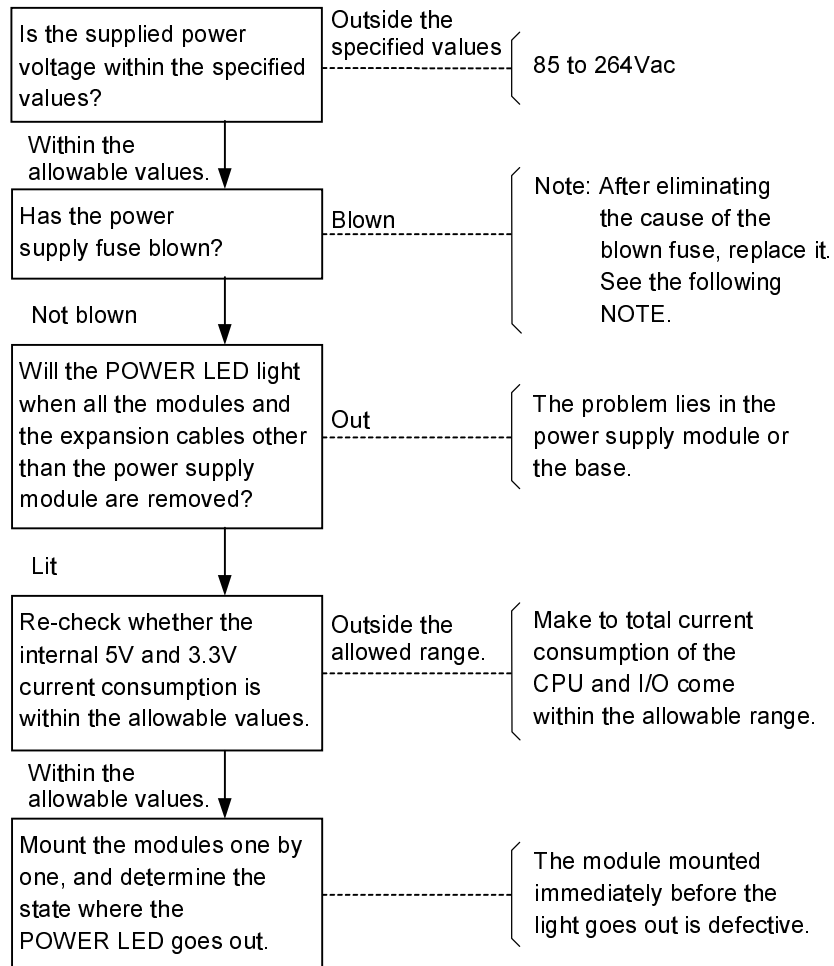

NOTE

1. When carrying out the above checks, always check each step after switching the power supply OFF again.
2. When a fuse has blown, always determine the cause of the blown fuse and eliminate it. If the fuse is replaced and the power supply is switched ON again without eliminating the cause, there is a risk of progressive damage to the module.
When the cause of the blown fuse cannot be determined, consult Toshiba without replacing the fuse.

6.3 Checking the S2T CPU

When the "POWER" LED of the power supply module is lit, but the "RUN" LED of the CPU module is out, check the following items.

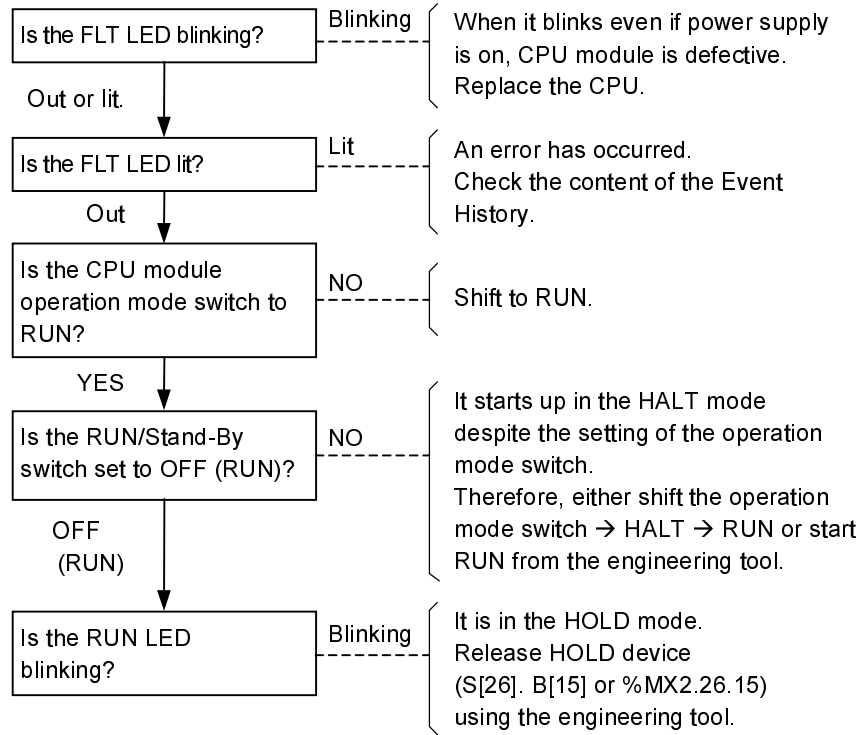

6.4 Checking user program

Check the program based on the following points if it is running but the operation does not work as intended.

- (1) Output is not carried on the same coil or register or variable of two or more locations during one scanning; the devices or variables for coil instructions and for function instructions are not overlapping.
- (2) The signal which changes faster than the scanning cycle is not input.
- (3) The instance name as time/counter instruction is not duplicated.
- (4) When an interrupt is used, the device/register which is used in the main program is not operated erroneously in the interrupt routine.

6.5 Checking input

If the program is running, but the input signal is not read normally, check the following points:

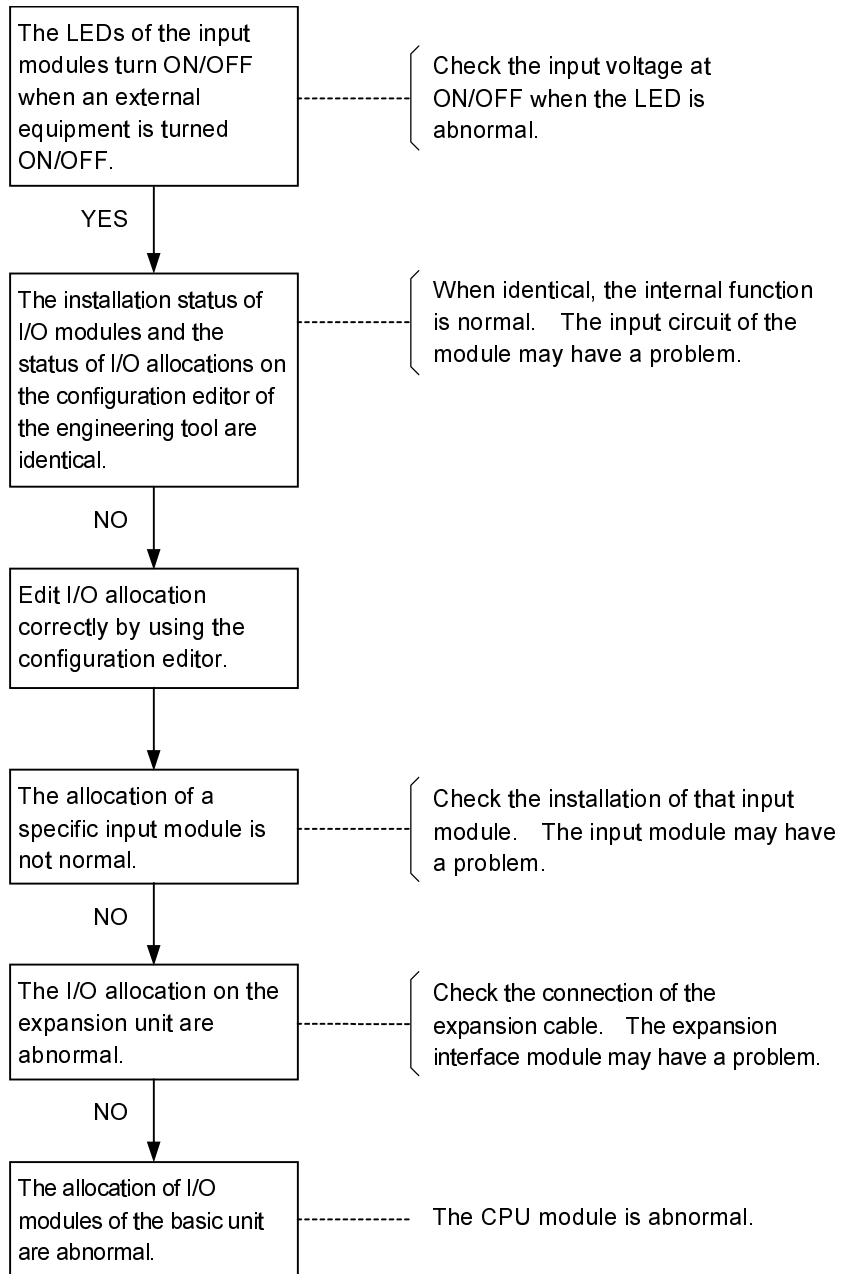

6

6.6 Checking output

When there is a problem with the actual operation of output equipment although correctly outputting to registers and variables on the program, carry out the following in preparation for checks.

- (1) Save the program. (In a HDD, MO, CD-ROM, DVD-RAM, etc)
- (2) Clear the CPU memory.
- (3) Put the ROM/RAM shift switch to RAM (ON).

After making the above preparations, carry out checks in the following sequence.

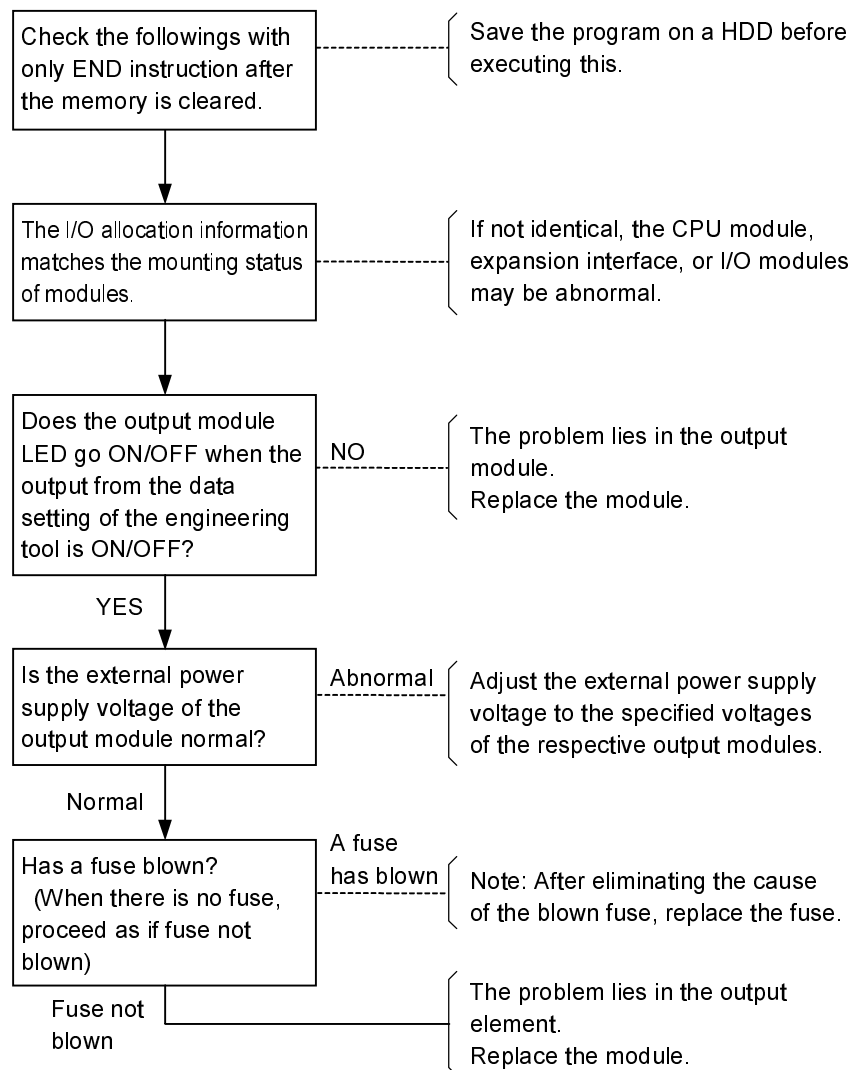

6.7 Troubles due to external factors

When a problem with the S2T system occurs as one of the following phenomena, external factors should be suspected.

- (1) If an abnormality occurs synchronously with the operation of I/O equipment:
The noise caused at ON/OFF of the output equipment may be the source of the abnormality. Take necessary measures mentioned in Section 3 Precautions for I/O modules.
- (2) If an abnormality occurs synchronously with the operation of surrounding equipment or high-frequency equipment:
The noise induced on I/O signal lines may be the source of the abnormality. The surge voltage, voltage fluctuations, or differences of grounding potentials may have caused the abnormality, depending on the power supply system or the grounding system.
Check that the abnormality in accordance with the precautions in Section 4 Installation and Wiring. For some cases, isolation from the ground may lead to the stable operation.
- (3) If an abnormality occurs synchronously with the operation of machinery:
The vibration of the equipment may have caused the abnormality.
Check that the installation status of the units and modules and take necessary measures, including the use of vibration-proof installation.
- (4) If a similar failure is repeated after the module is replaced:
Check that no metal debris or water drops have been entered into the unit/module. Apart from the above points, consider environmental conditions.
If the ambient temperature is beyond the specified range, stable operation of the system is not guaranteed.

Apart from the above causes, if, for instance, the ambient temperature exceeds the specified range, stable operation of the system cannot be guaranteed. Take thorough precautions over the environmental conditions.

B

- Base 51
- Basic Unit 2, 5, 51, 53
- Battery 148

C

- Computer Link function 18
- Computer Link mode 14
- Computer Link Protocol 25
- Controller 1
- Current Consumption 57, 58

D

- Direct I/O Module 2, 4, 60

E

- Expansion Base 5
- Expansion Cable 53
- Expansion Interface 53
- Expansion Unit 2, 5, 53, 132

F

- Frame Ground Terminal 55

I

- Initial Load 11
- Integrated Controller Vseries xi, 1
- Intelligent I/O Module 4

L

- Line Filter Ground Terminal 55
- LINK Port 10, 14, 17

M

- Main Base 5

N

- Network 1
- Network Modules 62

O

- Operation Mode Switch 10, 11

P

- Power Supply Module 54
- Protect RUN Switch 12

INDEX

R

ROM/RAM Switch	12
RUN Signal Output	55
RUN/Stand-by Switch	12

S

Safety Circuit	143
Setting Switches of Operation Mode	10, 12
Space Module	4, 9, 52
Station Module	1, 2, 4
Status Display LEDs	10, 11

U

Unit	51
Unit Cover	4, 8
Unit No.	51, 53

W

Weight	54, 57, 58
--------	------------

Integrated Controller V series
model 2000 Sequence Controller S2T User's Manual -Basic Hardware-

2nd edition

28th February 2003

0926.2.0302

TOSHIBA CORPORATION
SOCIAL INFRASTRUCTURE SYSTEMS COMPANY
CONTROL & MEASUREMENT SYSTEMS DIVISION

1-1, Shibaura 1-chome, Minato-ku, Tokyo 105-8001, Japan
Tel.:+81-3-3457-4900 Fax.:+81-3-5444-9268

© TOSHIBA Corporation 2003
All Rights Reserved.

Integrated Controller **V** series

model 2000 Sequence Controller
S2T User's Manual — Basic Hardware —

TOSHIBA